

1932 200

SHORT WAVE CRAFT

Edited by
HUGO GERNSBACK

IN THIS ISSUE

- NEW 2-R.F. PENTODE SHORT WAVE RECEIVER
- BUILDING A S-W SUPER-HET
- THE DENTON S-W "STAND-BY" RECEIVER —WORKS LOUD-SPEAKER ON 3 TUBES
- A 17 TO 300-METER S-W RECEIVER
- HEINRICH HERTZ INSTITUTE (BERLIN), By DR. ALFRED GRADENWITZ
- 4.9-METER RECEIVER, By THOMAS A. MARSHALL
- EXPERIMENTS WITH 3-METER TRANSMITTER, By DR. W. MOLLER
- A PRACTICAL 5-METER PHONE TRANSMITTER, By R. L. TEDESCO, WICAC and A. TEDESCO, WIBMB
- NEWEST S-W CONVERTERS

Now
25¢



April

At Last! A 2 R. F. Stage Pentode Receiver That Works!



9-COIL CIRCUIT
NEW TYPE SUPER-HETERODYNE

ONE CONTROL - 18 TO 550 METERS

FINEST BROADCAST RECEPTION

SUPER-SENSITIVE ON SHORT WAVES

NEW DESIGN - NEW RESULTS



THE NEW PILOT DRAGON 4-BAND SET

Just out — PILOT CATALOG!

Just out — PILOT catalog!

Everything for the service man, set builder, and experimenter is to be found in the new PILOT catalog.

REPLACEMENT PARTS. All PILOT's replacement parts are listed. They include power transformers, all types of resistors, dry electrolytic condensers, loudspeakers, chokes, and other manufacturers' type parts for Service Men.

EXPERIMENTERS' PARTS. New instruments for experimenters have been added, making PILOT's line of parts the most complete offered by any Company.

SHORT WAVE EQUIPMENT. PILOT has always been headquarters for short-wave equipment. The new catalog and a supplement now in preparation include everything for building short-wave receivers.

S.W. TYPE 224-A TUBES. The PILOT 224-A tube is especially designed to reduce noises in S. W. receivers. It will improve your results.

WRITE TODAY. Send 5c in stamps for the PILOT catalog or, better, send 50c for a year's subscription to Radio Design Quarterly and the catalog and supplement will be sent FREE. Don't delay! Do it today!



POLICE ALARMS - AIRPLANES IN FLIGHT } PLUS REGULAR
SHIPS AT SEA - FOREIGN STATIONS } BROADCASTING

You'll put your O.K. on this set as the most beautiful piece of radio design you have ever seen. Ask your dealer to show you how the DRAGON wave-band switch changes from three coils for broadcast pre-selection to any independent pair of coils for each of the three short-wave bands. Notice how other sets using tapped coils, loaded with dead end losses, fail at high frequencies. Listen to the DRAGON's freedom from inter-band interference in contrast to results on makeshift tapped-coil circuits. Examine the precision construction of the 9-coil catacomb. Listen to the quality of the new amplifier and the acoustic cabinet. Then you'll say, "That's my idea of a Radio Set!" and you'll tell your B.C.L. friends so, too.

NO PLUG-IN COILS

This 9-coil catacomb and switch is built into the chassis of the new DRAGON all-wave receiver. This method of construction eliminates all dead-end losses.

Complete information about the DRAGON receiver will be sent to you free if you will include your radio dealer's name and address with your request.



PILOT RADIO & TUBE CORP.

(Short Wave Headquarters - Established 1908)

FACTORIES - LAWRENCE, MASSACHUSETTS



WORK FOR YOURSELF • SET YOUR OWN PAY BEGIN NOW • WE'LL HELP

If your pay has been cut—or, if you're slaving away on some hopeless job—here's your chance to get on your feet in a hurry! R. T. A.—one of the oldest, best known radio organizations in the world—offers you the opportunity to go to work for yourself—to name your own pay—and to start making money almost at once. R. T. A. is not just a school that teaches you and then lets you shift for yourself. Instead, R. T. A. makes you a Certified Radiotechnician and provides you with a wonderful service outfit that makes money for you just as soon as you get it. Real money too—up to \$20 a day! With R. T. A. Training and with the R. T. A. Set Analyzer and Troubleshooter you should be the most popular radio service man in town, and have all the business you want to take care of. No pay cuts—no worry about losing your job—nobody to boss you but yourself.



SEND COUPON for NO-COST MEMBERSHIP PLAN

We have worked out a truly wonderful plan whereby R. T. A. membership, the R. T. A. Course, and the R. T. A. Set Analyzer and Troubleshooter need not cost you a cent. The coupon will bring you full particulars. Clip—fill in—mail now! Today!

RADIO TRAINING ASSOCIATION OF AMERICA
4513 Ravenswood Ave., Dept SWC-1 Chicago

Send me full particulars of your No-Cost Membership Plan.

Name

Street

Town State

RADIO TRAINING ASSO. OF AMERICA
4513 RAVENSWOOD AVE. Dept. SWC-4 CHICAGO, ILLINOIS

HUGO GERNSBACK, Editor

H. WINFIELD SECOR, Managing Editor

CONTENTS

APRIL, 1932

In This Issue: Prominent Short Wave Authors

Mouromtseff—Gradenwitz—Hertzberg—Denton—Moller—Rohde—Martin—Marshall—Silver

FEATURES:

Editorial—"SHORT WAVE CRAFT" Now a Monthly, by Hugo Gernsback.....	377
Can We Radio Mars?—"Yes—With 16-Inch Waves!" says Dr. I. E. Mouromtseff.....	378
Short Waves to Trap Crooks! by "Bob" Hertzberg.....	379
How Radio Research Is Carried on at the Heinrich Hertz Institute in Berlin—Described by Dr. Alfred Gradenwitz.....	380
2 R.F. "Pentode" Short Wave Receiver, by C. E. Denton and H. W. Secor.....	382
A Practical 5-Meter Phone Transmitter, by R. L. Tedesco, WICAC, and A. Tedesco, WIBMB..	386
3 Meters!—Demonstrations With a U. S. W. Transmitter, by Dr. W. Moller.....	388
Portable S-W Receiver, by "Bob" Hertzberg.....	390
A Crack German S-W Station, D4AA1, by Dr. L. Rohde.....	391
The New Hammarlund All-Wave "Comet" Receiver, by Lewis W. Martin.....	393
Denton "Stand-By" 3-Tube Short Wave Receiver, by Clifford E. Denton, Its Designer.....	395
Solving the Present Broadcast Problem, Thomas A. Marshall.....	398
S-M 727—Introduces a New "All-Wave" Principle, by McMurdo Silver.....	400
The "Midwest" S-W Converter, by W. A. Smith..	406

SHORT WAVES FOR THE BROADCAST LISTENER:

The New Hammarlund All-Wave "Comet" Receiver	393
S-M 727—The New Silver-Marshall All-Wave Receiver.....	400
A S-W Adapter, by W. Burmeister.....	403
The "Midwest" S-W Converter.....	406
What Time and Season to Listen On Certain Wave Lengths, by M. H. Gernsback.....	407

Short Wave Stations of the World—Operating "Time-Table".....	410
When to Listen In.....	425

SHORT WAVE RECEIVERS:

2 R.F. Pentode Short Wave Receiver, With 2 R.F. Stages That "Work"!!.....	382
Short Wave Receiver "Coil Winding Data".....	387
A Portable S-W Receiver for Your Vacation and Week-End Jaunts.....	390
A 17 to 300-Meter S-W Receiver, by Dale Tisdale.....	392
The New Hammarlund "All-Wave" Receiver.....	393
The Denton "Stand-By" 3-Tube Receiver That "Works Loud Speaker".....	395
S-W Converter That Works to Below 5 Meters....	398
The New Silver-Marshall "All-Wave" Receiver—SM-727.....	400
A S-W Adapter—How to Make It.....	403
Building a Short Wave "Super-Het," by A. Poltheim.....	404
The "Midwest" S-W Converter, by W. A. Smith....	406
A 4 to 7 Meter Receiver That Works! by G. J. Herrscher, W2APW, and E. P. Hufnagel, W2BUK.....	409

SHORT WAVE TRANSMITTERS:

A Practical 5-Meter "Phone" Transmitter.....	386
3-Meter Transmitter, by Dr. W. Moller.....	388
Transmitter at German Station D4AA1.....	391
Microphone Amplifier Circuit.....	412

MISCELLANEOUS:

Valuable Coil Winding Data.....	387
Luxtron Selenium Cell and Relay.....	402
Letters From S-W Fans.....	408
Short Wave Stations of the World—Operating "Time-Table".....	410
Short Wave Question Box, by R. William Tanner..	412
"When to Listen In".....	425
New Harrison S-W Receiver.....	427

IN OUR NEXT ISSUE

How to Build a S-W "Police Thriller"
 Honolulu to New York on Short Waves
 5-Meter Receivers, by A. Binnewig, Jr., Short Wave Specialist
 "Dead Spots"—Their Cause and Cure, Edgar Messing, Radio Engineer
 Simple Transmitters and Receivers for Ultra Short Waves, by Kurt Nentwig, Famous European S-W Expert

Radio Ghost—Do S-W Echoes Come From Space?, by Dr. F. Wolf, Instructor, Technical High School—Danzig, Germany
 Experiments With Ultra Short Waves—Profusely Illustrated; Describing Transmitters and Receivers Used for 3 to 10-Meter Experiments, by Robert Kratzenstein.
 The Te-Ka-De, 1-Centimeter (2.54 Inch) Wave Transmitter and Receiver, by Dr. Fritz Noack

OUR COVER — Illustrates the Newest Idea in Ultra-Efficient S-W Receivers, Utilizing Two Stages of T.R.F. With the New R.F. "Pentode" Tubes, and "Plugless" Coil Switching. See page 382

SHORT WAVE CRAFT—Monthly. Entered as second class matter May 7, 1930, at the post office at Mount Morris, Illinois, under the act of March 3, 1879. Trademarks and copyrights by permission of H. Gernsback, 98 Park Place, N. Y. C. Text and illustrations of this magazine are copyright and must not be reproduced without permission. SHORT WAVE CRAFT is published on the 15th of every month. Twelve numbers per year. Subscription-price is \$3.00 a year in the United States and possessions. Canada and foreign countries, \$3.50

a year. Single copies 25c. Address all contributions for publication to Editor, SHORT WAVE CRAFT, 96-98 Park Place, New York, N. Y. Publishers are not responsible for lost manuscripts. Contributions cannot be returned unless authors remit full postage. SHORT WAVE CRAFT is for sale at all principal newsstands in the United States and Canada. European agents: Brentano's, London and Paris. Printed in U. S. A. Make all subscription checks payable to Popular Book Corporation.

London Agent:
 HACHETTE & CIE.,
 16-17 King William St.,
 Charing Cross, W. C.2

Paris Agent:
 HACHETTE & CIE.,
 111 Rue Reaumur

COPYRIGHT, 1932, BY H. GERNSBACK

Published by POPULAR BOOK CORPORATION

HUGO GERNSBACK, President - H. W. SECOR, Vice-President
 EMIL GROSSMAN - Director of Advertising
 Chicago Adv. Office - L. F. McCLURE, 737 No. Michigan Blvd.

Publication Office, 404 N. Wesley Avenue, Mount Morris, Ill.
 Editorial and General Offices, 96-98 Park Place, New York, N. Y.

Australian Agents:
 MCGILL'S AGENCY,
 179 Elizabeth St.,
 Melbourne

OPPORTUNITIES are many for the Radio Trained Man

Don't spend your life slaving away in some dull, hopeless job! Don't be satisfied to work for a mere \$20 or \$30 a week. Let me show you how to get your start in Radio—the fastest-growing, biggest money-making game on earth.

Jobs Leading to Salaries of \$50 a Week and Up
Prepare for jobs as Designer, Inspector and Tester—as Radio Salesman and in Service and Installation Work—as Operator or Manager of a Broadcasting Station—as Wireless Operator on a Ship or Airplane, or in Talking Picture or Sound Work—HUNDREDS of OPPORTUNITIES for a real future in Radio!

Ten Weeks of Shop Training

We don't teach by book study. We train you on a great outlay of Radio, Television and Sound equipment—on scores of modern Radio Receivers, huge Broadcasting equipment, the very latest and newest Television apparatus, Talking Picture and Sound Reproduction equipment, Code Practice equipment, etc. You don't need advanced education or previous experience. We give you—**RIGHT HERE IN THE COYNE SHOPS**—the actual practice and experience you'll need for your start in this great field. And because we cut out all useless theory and only give that which is necessary you get a practical training in 10 weeks.

TELEVISION and TALKING PICTURES

And Television is already here! Soon there'll be a demand for THOUSANDS of TELEVISION EXPERTS! The man who learns Television now can have a great future in this great new field. Get in on the ground-floor of this amazing new Radio development! Come to COYNE and learn Television on the very latest, new-

est Television equipment. Talking Picture and Public Address Systems offer opportunities to the Trained Radio Man. Here is a great new Radio field just beginning to grow! Prepare NOW for these wonderful opportunities! Learn Radio Sound Work at COYNE on actual Talking Picture and Sound Reproduction equipment.

All Practical Work At COYNE In Chicago

ALL ACTUAL, PRACTICAL WORK. You build radio sets, install and service them. You actually operate great Broadcasting equipment. You construct Television Receiving Sets and actually transmit your own Television programs over our modern Television equipment. You work on real Talking Picture machines and Sound equipment. You learn Wireless Operating on actual Code Practice apparatus. We don't waste time on useless theory. We give you the practical training you'll need—in 10 short, pleasant weeks.

Mail Coupon Today for All the Facts

H. C. LEWIS, President
Radio Division, Coyne Electrical School
500 S. Paulina St., Dept. 52-2K, Chicago, Ill.

Dear Mr. Lewis:— Send me your Big Free Radio Book, and all details of your Special Offer.

Name

Address

City State



Many Earn While Learning

You get Free Employment Service for Life. And don't let lack of money stop you. Many of our students make all or a good part of their living expenses while going to school and if you should need this help just write to me. Coyne is 32 years old! Coyne Training is tested—proven beyond all doubt. You can find out everything absolutely free. Just mail coupon for my big free book!

H. C. Lewis, Pres. RADIO DIVISION Founded 1899
COYNE Electrical School
500 S. Paulina St., Dept. 52-2K, Chicago, Ill.

APRIL SPECIALS!!

NOTICE our important New departure in announcing Special values. Every month we will show on this page certain **STAR** items, which are **NOT LISTED IN OUR CATALOG**. These are all specials of which the quantities on hand are not sufficient to catalog them. *Once sold out, no more can be had.*

STOP SHOPPING. The lowest prices are right on this page. *No one undersells us.* We meet any price on **ANY NEW** Merchandise. Order direct from this page and save money. 100% satisfaction on every transaction. Take advantage of these special offers. **ORDER NOW, TODAY.**

NEW! "LITTLE GIANT" DYNAMIC SPEAKER



Absolutely the smallest dynamic speaker that will withstand the strain of modern output power tubes, ever manufactured.

Suitable for use on midset, portable and automobile receivers. Measures but 6 1/4 in. long over-all, having a 4 1/4 in. diaphragm and weighing but 4 lbs. The "Little Giant" has, under test, actually flooded a ten-room apartment with faithfully reproduced music of virtually original tone duality. Field winding has a resistance of 2500 ohms and may therefore be energized by using it as a filter choke in the power pack, thereby serving a double purpose. This last feature makes the "Little Giant" excellently suited for portable A.C. sets, since it does away with filter chokes and thus with considerable weight. Equipped with built-in output transformer to work from any standard output power tube arrangement. Specify the power tube or tubes used when ordering. Shipping weight 5 lbs. List Price \$6.50. No. 1549. **LITTLE GIANT DYNAMIC SPEAKER. Your Price \$2.50**

***UTAH A.C. DYNAMIC SPEAKER—Only a Few Left**



110 volt, 60-cycle A.C. light socket supply for field excitation with Westinghouse dry rectifier. 9 in. high, 9 1/2 in. wide, 7 1/2 in. deep. Speaker comes packed in wooden crate. Weight 19 lbs. It is one of the most powerful as well as best reproducers in the market. 9-inch cone. List Price, \$50.00. No. S.P. 1506—Your Special Price **\$7.45**

***FARADON 4-MFD. FILTER CONDENSER**



Here is just the condenser for constructing noise filters. In some cases one condenser connected across the line or instrument will be sufficient. However, in most commercial filters there are two condensers connected in series; the center-tap being grounded and the two remaining leads connected across the light line or the interference-producing apparatus. Put up in a neat, black-enamelled case with tinned lugs for soldering connections. 2" high x 3 1/2" wide x 2 1/4" deep. Working potential 600 vts. 184. Ship. wt. 6 lbs. List Price \$7.50. No. S.P. 9062—Faradon 4 Mfd. **\$1.50** Filter Condenser. Your Price

World-Wide Short-Wave Set NOT A CONVERTER



A perfect radio short-wave receiver for use between 18 and 200 meters. To put into operation, connect antenna, ground, 15-volt "B" and two No. 6 dry cell "A" batteries, and headphones to the posts provided, plug in a type 30 tube, and tune in! An ingenious circuit makes possible a 4-coil single-winding plug-in design. This little instrument has the same sensitivity as many big, shielded short-wave receivers costing ten times as much. A power amplifier may be added for any degree of volume. Complete with 4 plug-in coils. Has fine vernier dial for precision tuning. Never has a first class short-wave set sold for so little money. This short-wave set measures 5 1/2 x 7 x 1 in. high, over-all. Ship. weight, 3 lbs. List price, \$12.50. No. 1666—World-Wide S.-W. Set. **\$6.25** Your price.

NEW! NEW! SYNCHROMATIC ELECTRIC CLOCK



Never was such a first class electric clock sold at such a ridiculously low price! An electric clock using the famous synchromatic movement. Naval observatory time right from your light socket! No spring to wind, no batteries. Never out of order. Lubricated for a life-time at the factory. The entire movement with its white-enamelled dial and artistic numbering is enclosed in a dust-proof and shockproof genuine molded Bakelite case. The case is of walnut-brown finish with simple but catching design. For 110 volts, 60 cycle A.C. operation only. Complete with cord and attachment plug. Size 3 1/4" x 1 1/4" x 1 1/4". Weight 1 lb. Service men now sell these fine clocks by the hundreds. Be the first in your locality to handle them.

List Price \$3.00. No. 1689—Synchromatic Electric Clock. **Your Price \$1.00**

FREE 76 Page Radio Treatise No. 24



The new Winter edition of our RADIO SERVICE TREATISE, twice as large as our former one, has just come off the press. It is positively the greatest book in print—NOT JUST A CATALOG. It contains a large editorial section—a veritable book in itself—with valuable information **NOT FOUND ANYWHERE ELSE**. Among the wealth of new technical information listed in the editorial sections are the following: 1932 Complete Radio-tion Characteristics **SHORT-WAVE TUNERS** and **PHONO-PICKUPS**.—Constructural Data of **SERVICEMEN'S TEST OSCILLATOR—ALL ABOUT TONE CONTROLS—SHORT-WAVE ADAPTERS AND CONVERTERS—CONSTRUCTING A 3-TUBE SUPER-HET SHORT-WAVE CONVERTER.—MODERNIZING OLD RADIO SETS.—BEST TYPE MULTI-MU AND PENTODE TUBES.—ALL ABOUT DC RECEIVERS.—VACUUM TUBES TREATISE.**—And dozens of new radio experiments, hints to Servicemen, valuable tables of useful data, etc., etc.

This book is not just another catalog but a veritable mint of radio information which will be of infinite and everlasting value to you.

WRITE TODAY. Enclose 2 cents for postage. Treatise sent by return mail.

6 MONTHS GUARANTEED NEONTRON TUBES

Sold on a 6 MONTHS FREE REPLACEMENT GUARANTEE BASIS, PROVIDING TUBE LIGHTS! All tubes are carefully meter-tested before shipment, and carefully packed. Do not confuse these HIGH QUALITY tubes with any other "low priced" tubes—our low prices are possible because we do a VOLUME business!

Choice			NEW		
Choice Price	Choice Price	Choice Price	Choice Price	Choice Price	Choice Price
226	112A	215	222	230	235
227	200A-199X	280	223	231	247
171A	1991V-120	171	210	232	238
201A	221		250		236-37
			241		551

60c ea. 69c ea. 70c ea. 1.58 ea. 1.08 ea. 1.08 ea.

R.C.A. LICENSED TRIAD AND SPEED TUBES

These nationally advertised tubes are guaranteed UNCONDITIONALLY for six months. The prices are slightly higher than our NEONTRONS because these tubes are of much better quality. See listing above for tube numbers.

Choice Price	Choice Price	Choice Price	Choice Price	Choice Price	Choice Price
63c	80c	75c	\$1.76	\$1.15	\$1.15

***"POROX" 2-VOLT STORAGE CELL**

5 Ampere-Hours—For 2-Volt Tubes

One such unit will light a two-volt battery tube for 75 hours continuously. Will handle two 2-volt tubes for 35 hours, etc.

Put up in a transparent composition container with two non-corroding terminals clearly marked as to polarity. Easily recharged either directly from a 110 volt D.C. line in series with a 40 watt electric light bulb or from an "A" eliminator in series with a 12 ohm 2 watt resistor. Excellent for use in any circuit requiring a steady source of current. 3" wide x 4" high x 3/8" thick. Instructions included. Ship. wt. 2 lbs. List Price \$4.50. No. S.P. 9060—Porox 2 Volt Storage Cell. **Your Price \$3.80**

NEW RESONANCE TUNING METERS



This ingenious device INDICATES VISUALLY when a station is exactly "tuned-in-on-the-dot." Receiver is tuned to its most critical resonance point for any given station when needle swings to farthest position. Servicemen profit by installing these meters in sets which are not so equipped. Have only scales and pointers visible through an escutcheon plate. Used in new Stromberg-Carlson sets.

EXCELLENT TUNING DEVICE FOR SHORT-WAVE RECEIVERS. The extremely sharp tuning short-wave stations are very easily detected by this visual indicator where the ear usually misses them. Easily installed on any receiver by placing it in series with the plate of the power tube. Shipping wt. 1/2 lb. Available in two styles.

TM-103—(Illustrated) Enamel finished dial—lighted from flat side of the case over the top of the dial.

TM-100—Translucent dial—lighted from a rear window. **Your Price \$1.90**

List Price \$1.50. Escutcheon Plate\$2.25 extra Pilot light and bracket.....\$3.30 extra

***VERSATILE PORTABLE PUBLIC ADDRESS SYSTEM**

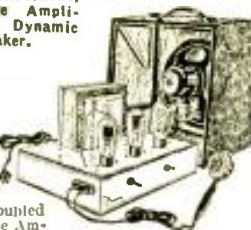

Comprises Microphone, Loftin-White Amplifier and Dynamic Speaker.

A recently completed all-electric A.C. development incorporating all the features and advantages of the direct-coupled Loftin-White Amplifier principle.

This amplifier is a high quality two stage job, having some **RADICALLY NEW IDEAS IN AUDIO FREQUENCY AMPLIFICATION** and employing 1-27, 1-15 power tube and 1-80 full-wave rectifier. It is remarkably free from A.C. hum.

The design is adaptable to all purposes, i.e., microphone, radio and phonograph. Has an undistorted power output of approximately 3.5 watts; **SUFFICIENT TO OPERATE FROM 2 TO 3 ADDITIONAL DYNAMIC SPEAKERS.**

The portable address system is sold COMPLETE WITH THE NEW R.C.A.-VICTOR HAND MICROPHONE—a sturdily constructed unit which will withstand a lot of rough handling.

Put up in a single compact and perfectly balanced carrying case, the front of which is utilized as a baffle for the self-contained dynamic speaker. Complete with microphone and accessories the weight is only 30 pounds. For 50-60 cycles, 110-20 volts A.C. operation. Shipping weight 38 pounds. List Price, \$75.00. No. S.P. 9063—Versatile Portable Address System. Your Price, complete with microphone **\$25.50**

***R.C.A.-VICTOR HAND MICROPHONE**



The most ruggedly constructed hand microphone ever manufactured. There is not another of its kind that is quite as sensitive. Designed especially for home recording and personal entertainment. Requires but a 2 1/2 volt battery to operate. Easily connected to any radio or amplifier in a few minutes. This unit is essentially a single button carbon microphone—acoustically centered in a stout metal housing which serves the dual purpose of protection and noise shielding. Responds indiscriminately to all speech and music frequencies. Has a high D.C. resistance and may therefore be shunted directly across the grid and cathode of the detector tube without employing a coupling transformer. Sold complete with 6 ft. connecting cable. Shipping weight, two pounds. List Price, \$10.00. No. S.P. 9064—R.C.A.-Victor Hand Microphone. Your price **\$2.75**

Screen Grid Cap Connectors

Newest SCREEN GRID CAP. Small, neat in appearance and unusually constructed. A stark necessity in service work. Sold only in lots of 12 or more. Shipping weight 4 oz. No. 1672—Screen Grid Cap Connector. Your Price.....Dozen **\$12**

***Guaranteed 8-Mfd. Electrolytic Condensers**



Judiciously used in many parts of any R.F. or A.F. circuits, in power packs, in dynamic speakers, they will perform miracles in eliminating any trace of objectionable A.C. hum or other incidental disturbances. These electrolytic condensers are particularly recommended for 250 power packs. Where the working voltage of the unfiltered A.C. is 800 volts, two electrolytic condensers in series will stand up indefinitely. Easily mounted through the use of a bayonet socket base which is equipped with a "positive contact" spring. Totally shielded and protected by a copper can. Shipping weight—1 lb. List Price, \$2.50. No. SP9054—Guaranteed 8 Mfd. Electrolytic Condenser. Your Price.... **\$4.9**

WE ARE A WHOLESALE HOUSE AND CANNOT ACCEPT ORDERS FOR LESS THAN \$3.00.

If C. O. D. shipment is desired, please remit 20% remittance, which must accompany all orders.

If full cash accompaniment order, deduct 2% discount. Send money order—certified check—U. S. stamps.

Radio Trading Co.
25A West Broadway
New York, N. Y.

ORDER FROM THIS PAGE. You will find special prices from time to time in this magazine. Get our big FREE catalog for the greatest Radio Bargains.

Should you wish goods shipped by parcel post, be sure to include sufficient extra remittance for same. Any excess will be refunded.



ZEESEN
Germany

The ONLY



J. O. A. K.
Japan

RECEIVER that dares to promise daily 'round the world Performance

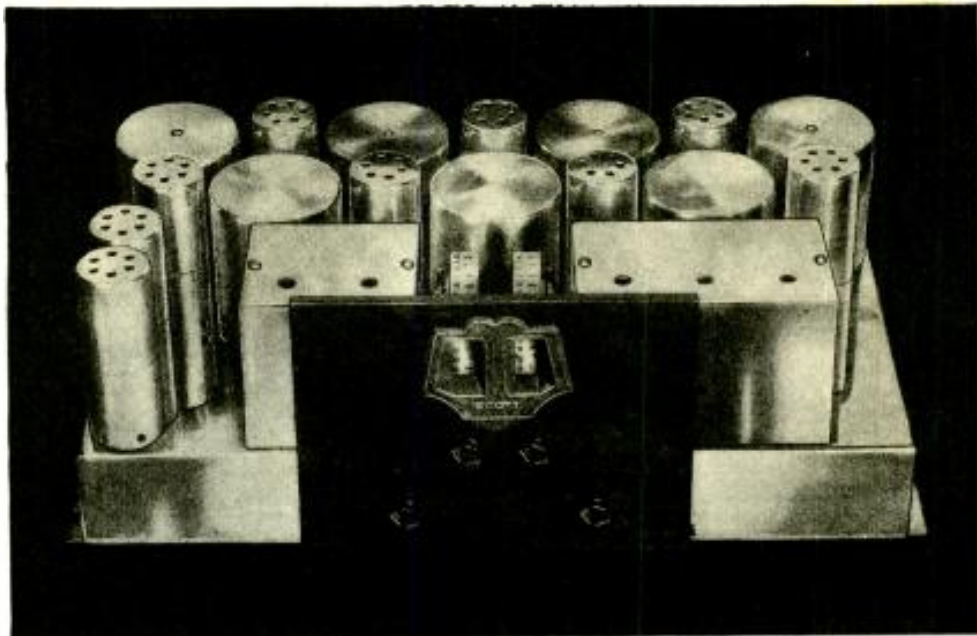

From all over the world
come letters like these

Excellent Program From Germany

"I have received with ample volume Rome, Italy; FYA, France, its three wave lengths; GSSW, England; ZEESEN, Germany; and half a dozen HK's from South America, not forgetting VK2ME, Australia. I was particularly pleased with the excellent reception from Zeesen, Germany."
F. S., New York City, N. Y.

Wished He Knew a Dozen Languages

"If I knew a dozen different languages I could have put them all to good use today. At 10:30 A. M. today I tuned in a French station and stuck with it until 11:00 A. M. when they quit after playing a phonograph record entitled 'Marseilles.' I received two Spanish stations I could not identify. Another station that sounded very much like Chinese, also went by the board. I was well repaid for my patience when I tuned in 12RO, Rome. Here was real reception—volume great enough to fill an auditorium, clear as a bell, no fading and no static at all. I held this station from 1:30 to 3:50 and heard every word uttered although I did not understand much of the language. Their signal was coming in very strong until 5:30 P. M."
S. M., McKeesport, Pa.

Indo-China Every Morning

"I get F31CD, Indo-China, every morning from six to eight our time and enjoy their program very much as it is very clear. Can also tune in stations in South America nightly."
F. L. F., Boise, Idaho

Italy and France All Week

"I have picked up these two stations all last week—12RO, Rome, Italy; FYA, Paris, France, from 2:30 P. M. until 5:00 P. M. with tremendous volume. I was able to listen to a program from England from 3:00 to 4:30 P. M. Sure was good reception. I can also get Spanish and South American stations."
A. M., Louisville, Ky.

- HEAR**
Radio Transmission from
- 1 Foreign Broadcast Stations
 - 2 Airplanes in flight
 - 3 Amateur phones
 - 4 Transatlantic phones
 - 5 Ships at sea
 - 6 Police departments
 - 7 Code stations all over world
 - 8 Domestic Stations

Out of the maze of radio claims and counter-claims—one FACT is outstanding. *The Scott All-Wave not only claims ability to tune in stations clear 'round the world, but presents undeniable proof of its world-wide prowess.* Then it crowns *proof of range with proof of regularity*—thereby establishing the Scott All-Wave as a 15-550 meter receiver you can *depend* upon to bring the whole world to your ears whenever you choose.

Here's the proof: During the last 8 months every bi-weekly broadcast (excepting three) put on the air by VK3ME, Melbourne, Australia—9,560 miles from Chicago—has been received here, recorded on disc and verified. You can hear these recordings at the Scott laboratories any time you wish. You

can also hear records made of reception from Japan, France, Germany, England, and South America; reception picked up by a Scott All-Wave right here in Chicago. In other words, you can have ACTUAL PROOF of this receiver's ability *before* you buy it! And if you came here to the Scott laboratories you would see why the Scott All-Wave can promise *daily* 'round the world performance—and why all Scott All-Wave Receivers are identical in capability.

The reason, of course, is advanced design and precision work—every step of the job actually done in the laboratory and to strict laboratory standards. And every receiver actually tested on reception from London and Rome before shipping!

Get the only receiver that can promise *daily* 'round the world performance, and live up to it. Write now for full particulars of the Scott All-Wave. You'll be agreeably surprised at the most reasonable price.

The E. H. SCOTT RADIO LABORATORIES, INC.
(Formerly Scott Transformer Co.) 4450 Ravenswood Ave., Dept. SWC42, Chicago, Ill.

In a class by itself
—above comparison.
The Scott All-Wave
is the unchallenged
champion of the
radio world.

SCOTT

ALL-WAVE

15-550 METER

Superhetrodyne

THE E. H. SCOTT RADIO LABORATORIES, INC.
4450 Ravenswood Ave., Dept. SWC42, Chicago, Ill.
Send me full particulars of the Scott All-Wave 15-550 meter Superhetrodyne.

Set Builder Dealer DXer

Name.....

Street.....

Town.....State.....

Enjoy WORLD-WIDE Reception

With the New MIDWEST SHORT-WAVE CONVERTER!



Total of 15 Tubes When Used With AC-11....15 to 550 Meters

Again Midwest demonstrates its leadership by offering you radio's newest and most sensational development—WORLD-WIDE reception with an all-wave converter. This new Midwest converter readily converts any A.C. set of adequate sensitivity into a short-wave receiver for reception of police calls, airmail and passenger plane conversation, ships at sea, etc., and, under favorable radio conditions, even broadcasts direct from many foreign stations located throughout the world. This Midwest Converter uses 4 tubes and is self-powered—no drain on your set.

Self-Powered

Many converters recently put on the market depend on the radio for power which puts a strain on the power supply of the set. Not so with the Midwest Converter. It has its own power supply which not only avoids overloading the transformer and other parts of the set as well as poor reception due to reduced voltage.

Spring and Summer are Best For Short-Wave Reception

Have you ever listened to a program direct from Paris, France?—Berlin, Germany?—Havana, Cuba?—Genoa, Italy?—South America?—etc.? If not, you're missing the fascinating thrill of a lifetime. It seems like a dream to be able to pick up the flowing strains of a quaint old folksong or the fascinating rhythm of the latest Spanish dance direct from some far-off country. Yet, this new, different kind of entertainment is now within your reach. And remember! Right now, during early Spring and Summer, is the best time for short-wave reception.

only
\$16⁷⁵
COMPLETELY ASSEMBLED—

13 and 15 TUBE COMBINATIONS

This amazing new short-wave converter employs 4 tubes, having self-contained power unit. It uses one 230, two 227, and one 224 tubes. In combination with a 9-tube Super-Het, it gives you a 13-tube ALL-WORLD, ALL-WAVE combination. When used with the very latest model Midwest 11-tube super-heterodyne, shown on the opposite page, it gives you a total of 15 powerful tubes, and ALL-WORLD, ALL-WAVE reception unbeatable even in receivers costing several times as much.



Span the Ocean...

—defeat the barrier of space—enjoy the thrill of world-wide reception with the new Midwest Short-Wave Converter. It's fascinating, alluring entertainment. Hook up with a Midwest Converter and hear stations you never even dreamed existed.

EASY TERMS

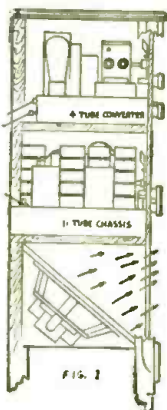

This diagram shows how the Midwest Converter and 9- or 11-tube Super-Het, are mounted in one cabinet, with speaker at the new improved angle. This makes a 13-tube or 15-tube All-World, All-Wave Combination. If desired, you may purchase converter chassis only and mount in your radio console; or better yet, purchase converter complete with cabinet to set on top of your console.

NO PLUG-IN COILS Every Important Feature

1. Ball-bearing variable condenser floated in rubber
2. Accurately peaked I. F. at 575 K. C.
3. No changes required in set
4. Complete power unit fil. and B supply (80 rectifier)
5. Self-healing electrolytics
6. Scientifically shielded
7. Noiseless low-loss switching device.
8. Thoroughly filtered
9. Non-regenerative detector
10. Vernier 6-1 slow motion dial (illuminated)
11. No troublesome body capacity
12. Proven circuit
13. Shielded output cable
14. Extremely simple to connect

MIDWEST RADIO CORP.

DEPT. 65, CINCINNATI, OHIO

MAIL  COUPON on Next Page for **BIG FREE CATALOG** and COMPLETE DETAILS

Only \$37.50

Pentode Variable-Mu and REAL AUTOMATIC VOLUME CONTROL

11-TUBE Super-Het.

RADIO FANS! What a radio! A powerful new 11-tube super-het. at an unbelievably low price. Reception equal to fifteen ordinary tubes — in a perfectly balanced, non-oscillating, non-radiating, super-heterodyne TENTUNED circuit with real automatic volume control that holds those powerful locals down to the same volume as the distant stations and counteracts that annoying fading on weak stations. Two Push-pull Pentode power output tubes with twice the power and four times the sensitivity of ordinary 45's—and Multi-Mu tubes, together with a -24 first detector, gives you SIX SCREEN GRIDS. These six screen grids, together with the -27 oscillator, second detector, first A. F., and automatic volume control—the -80 tubes—gives total of ELEVEN TUBES. The use of a band-pass or pre-selector stage, together with Multi-Mu full range tubes, makes this radio actually surpass 10 K. C. selectivity. Absolutely eliminates those noisy singing "birdies" and annoying cross talk. You'll be positively amazed and delighted when you see this sensational new set—hear the beautiful, mellow, cathedral tone—know what it means to have that pin-dot selectivity and unequalled sensitivity together with true tone fidelity. Be convinced—TRY A MIDWEST 30 DAYS BEFORE YOU BUY. Don't send a penny. Mail coupon right now for amazing FREE trial offer and complete details. You'll be surprised.

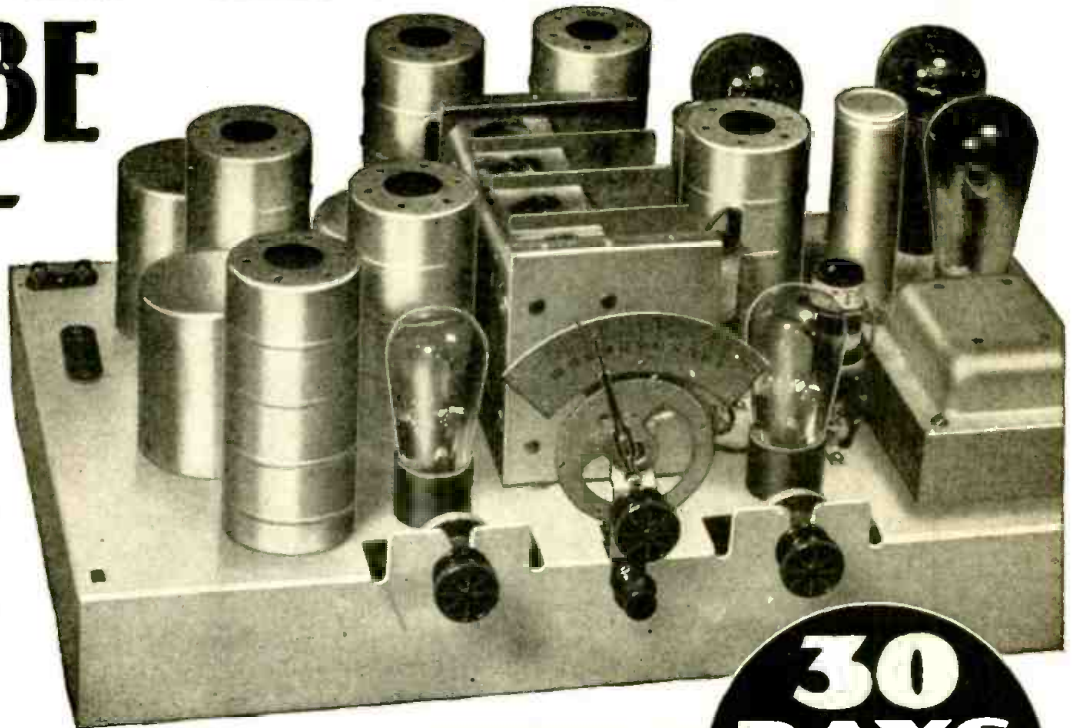

TERMS AS LOW AS \$5.00 DOWN

30 DAYS FREE TRIAL

Deal Direct with Factory SAVE UP TO 50%

Never before in the history of radio has such a powerful set been offered at Midwest's amazing low price. Deal direct with the big MIDWEST factory. Save the jobber's profit. Your outfit will reach you splendidly packed, rigidly tested with everything in place ready to plug in. No assembling! Entertain yourself for 30 days absolutely FREE—then decide. Save up to 50 per cent in buying direct from factory—insure satisfaction—deal direct with the world's veteran radio builders—MIDWEST. And don't forget—every MIDWEST outfit is backed by an absolute guarantee of satisfaction. You take no risk.



Complete Line of Consoles

Rush the coupon for big, beautiful catalog that illustrates the complete line of MIDWEST console cabinets. All new. All different. You'll gasp with admiration when you see the vast selection of beauty, style and grace that is crafted into every MIDWEST Console. The catalog is FREE—it doesn't cost you a penny! Rush the coupon—NOW!

Read What Enthusiastic Users Say!

California User Hears Japan and Australia

"It is a great thrill to jump to all parts of the U. S., Mexico, Canada, as well as Cuba and Honolulu, with my eleven tube Midwest. From 1:00 to 5:00 A.M. nearly all the Japanese and Australian stations come in, weather permitting. Every day I am finding new stations that I have never heard before."

Harry C. Jones, Graeagle, Calif.

Gets California, Mexico Havana, Nova Scotia

"I have received my Midwest set in perfect condition and am well pleased with the Lowboy Model L-11. I have received stations KFI and KGO in California, CMK—Havana, VAS—Glare Bay, N. S., XEII—Villa Acuña, Mexico. I have a lot of 38 stations for the first night. I have received police stations from Chicago and Cincinnati and am able to separate the stations better than I have seen on any other set regardless of price. I can compare my set with my mother's set which cost \$235.00, which is four times as much as I paid."

Edw. Billingham, Lebanon, Pa.

MAIL FOR BIG FREE CATALOG AND LIBERAL TRIAL OFFER

Midwest Radio Corp. Dept. 65, Cincinnati, Ohio

() Send me SPECIAL USER AGENT'S PROPOSITION

Without obligation send me your new 1932 catalog and complete details of 13- and 15-tube All-World, All-Wave Combinations, 4-tube Converter, 9- and 11-tube Super-Heterodynes, low factory prices, easy terms and liberal 30-day free trial offer. This is NOT an order. Name, Address, Town, State

MIDWEST RADIO CORP. DEPT. 65, CINCINNATI, OHIO

● ORDER DIRECT FROM THIS PAGE ●



WORLD'S BEST RADIO BOOKS

WE herewith present the most complete collection of recent important radio books. We have, after an exhaustive study, selected these volumes because they represent the foremost radio books of their kind in print today. There is such a great variety that we are sure it will satisfy any taste as well as any requirement that the student of radio might have. We publish no catalogue and ask you to be kind enough to order direct from this page. Prompt shipments will be made to you from the publishers. We merely act as a clearing house for a number of radio publishers and OUR PRICES ARE AS LOW OR LOWER THAN WILL BE FOUND ANYWHERE. Remit by money order or certified check, if you send cash, be sure to register it.

AIRCRAFT RADIO, by Myron F. Eddy. Cloth covers, size 6x8 3/4", 284 pages, 68 illustrations. **\$4.50**
A complete guide to the principles, selection, installation, operation and maintenance of aircraft radio.

THE RADIO HANDBOOK, by James A. Moyer and John F. Wostrel. Flexible covers, size 5 1/2 x 8 1/2", 886 pages, 650 illustrations. Price **\$5.00**
Comprehensive data on short-wave apparatus, vacuum tubes, modern radio receivers and transmitters, photoelectric cells, television, sound motion pictures, tables, graphs, diagrams, etc. No radio man should miss it.

RADIO FREQUENCY ELECTRICAL REQUIREMENTS, by Hugh A. Brown. Cloth covers, size 6x9", 386 pages, 235 illustrations. Price **\$4.00**
One of the few great books on this important subject. Everything from thermionic tube coefficients to piezoelectric measurements.

TELEVISION, Its Methods and Uses, by Edgar H. Folix. Cloth covers, size 5 1/2 x 7 3/4", 272 pages, 73 illustrations. Price **\$2.50**
A practical complete cross-section of television today. One of the very best books on this important art in print.

MAGNETIC PHENOMENA, by Samuel Robinson Williams. Cloth covers, size 6x9", 280 pages, 150 illustrations, and numerous tables. Price **\$3.00**
All electric motors, coupling coils, magnetic and dynamic loud-speakers, transformers, choke coils, etc., are dependent on magnetic phenomena. This fine book is complete on the subject.

HOW TO BUILD AND OPERATE SHORT-WAVE RECEIVERS, by the Editors of SHORT WAVE CRAFT. Stiff Paper covers, size 7 1/2 x 9 3/4", 76 pages, 250 illustrations. Price prepaid **50c**
The greatest book on building and operating short wave sets and converters in print today. No better book printed.

CINEMATOGRAPHY, by James R. Cameron. Stiff covers, size 7 1/2 x 5", 210 pages, 150 illustrations. Price **\$3.50**
Everything on the subject from "silent" and "talkie" 16 mm. film to its manufacture and to the final projection is in this marvelous volume.

QUESTIONS AND ANSWERS—Sound Motion Pictures, by James R. Cameron. Cloth covers, size 7 1/2 x 5", 250 pages. Price **\$3.50**
The most important book on the technical subject of "Talkies."

AUDELS RADIOMAN'S GUIDE, by Frank D. Graham. Cloth covers (flexible), size 5x6 3/4", 220 pages, 300 illustrations. Price **\$1.00**
A practical, concise book presenting the theoretical and practical information for the proper operation, maintenance and service as applied to modern radio practice.

THE RADIO AMATEUR'S HANDBOOK, (New Revised Edition), by A. Froelich Collins. Cloth covers, size 5 1/2 x 7 3/4", 368 pages, 109 illustrations. Price **\$2.00**
If you wish to become a radio amateur (radio ham) this book tells you how. Everything in receiving and transmitter sets and how to build them.

RADIO SET ANALYZERS AND HOW TO USE THEM, by L. Van der Mel. Stiff Paper covers, size 6x9", 68 pages, 45 illustrations. Price prepaid **50c**
The first book giving the fundamentals of radio servicing design in a manner which is clear even to the tyro. No service man can be without it.

RADIO AND ELECTRONIC DICTIONARY, by Harold P. Manley. Cloth covers, size 6x9", 300 pages, 550 illustrations. Price prepaid **\$2.50**
A fully indexed volume, which places at your finger-tips definitions of 3,800 radio words and phrases; of inestimable value.

FOUNDATIONS OF RADIO, by Rudolph L. Duncan. Cloth covers, size 5 1/2 x 8", 246 pages, 115 illustrations. Numerous tables. Price **\$2.50**
This textbook gives you the fundamentals of electricity as applied to radio. It equips you for further study in the field of radio.

EXPERIMENTAL RADIO ENGINEERING, by John H. Morecroft. Cloth covers, size 6x9", 346 pages, 250 illustrations. Price **\$3.50**
A student's book; devoted to the principles of radio apparatus; intended to accompany a course in electricity. The best of its kind.

TALKING PICTURES, by Bernard Brown. Cloth covers, size 5 1/2 x 8 1/4", 327 pages, 161 illustrations. Price **\$3.00**
The non-technical man reading this book feels that he has been transported to a wonderland; technicians refer to it time after time.

CONQUEROR OF SPACE—The Life of Lee de Forest, by G. Carnal. Cloth covers, size 5 1/2 x 8 1/4", 286 pages, illustrated. Price prepaid **\$3.00**
This is a biography of the "Father of Radio." De Forest is the most important figure in the development of modern radio.

THE RADIO AMATEUR'S HANDBOOK, 9th Edition. A Manual of Amateur Short-wave Radio-telegraphic Communication, by American Radio Relay League. Stiff paper covers, size 6 1/2 x 8 1/4", 160 pages, 227 illustrations. Price postpaid **90c**
No radio amateur needs to be told that this is the latest and most up-to-date edition of this famous manual. Over 100,000 sold.

RADIO AND ITS FUTURE, by Martin Codel. Cloth covers, size 6x9", 319 pages, 8 plates. Price **\$4.00**
Vivid chronicles of radio broadcasting, communications industry, regulations, etc. If you are in radio you MUST have this book.

SHORT WAVES, by C. R. Leutz and R. B. Gable. Stiff covers, size 6x9", 384 pages, 258 illustrations. Price, prepaid **\$3.00**
The biggest and most complete book on short waves. Covers every imaginable phase, including S.W. Super heterodynes. The authors are famous S.W. authorities.

RADIO FREQUENCY MEASUREMENTS, by E. B. Munnlin. Cloth covers, size 6x9", 487 pages, 289 illustrations. Price prepaid **\$12.50**
This large volume answers all questions which arise in the design and construction of R.F. circuits of every possible type. The greatest and most authoritative book of its kind in print for radio students and engineers.

RADIO MOVIES AND TELEVISION, by C. Francis Jenkins. Cloth covers, size 9 1/2 x 6", 111 pages, profusely illustrated. Price **\$2.25**
A complete volume by the master of television, giving everything in television, including constructional details for building your own television sets.

RADIO VISION, by C. Francis Jenkins. Cloth covers, size 9 1/2 x 6", 144 pages, profusely illustrated. Price prepaid **90c**
An excellent book. The Jenkins television system, as well as many other modern television systems fully described.

A POPULAR GUIDE TO RADIO, by B. Francis Dashiell. Cloth covers, size 5 1/2 x 8 1/4", 286 pages, profusely illustrated. Price prepaid **\$3.50**
The fundamental principles of radio. From crystal rectifiers to the latest electron tube amplification, etc.

RIDING THE AIR WAVES, by Eric Palmer, Jr. Cloth covers, size 7 1/2 x 5 1/2", 328 pages. Price **\$2.00**
No radio amateur or "ham" can afford to be without this book, written by the author of "Around the World with 5 Watts."

SOUND PICTURES AND TROUBLE SHOOTERS MANUAL, by Cameron and Rider. Cloth covers, size 8x5 1/4", 1120 pages, profusely illustrated. Price **\$7.50**
The standby of every operator. It is the most thorough book on the subject.

TELEVISION TODAY AND TOMORROW, by S. A. Mosley and H. J. B. Chapple. Cloth covers, size 8x5 1/4", 130 pages, profusely illustrated. Price prepaid **\$2.50**
A most up-to-date work on television describing in detail the apparatus used by Baird.

S. GERNSBACK'S RADIO ENCYCLOPEDIA (Second Edition), Red Morocco Flexible Binder, 372 pages, 2201 radio definitions, 1273 illustrations, 31 tables. Price **\$3.25**
The most comprehensive encyclopedia of its kind in print. Remarkably up-to-date in every way, with marvelous illustrations.

How to order
We cannot ship C.O.D. Our prices are net, as shown. Some of the books include postage. Those that do not will be shipped by express collect if sufficient postage is not included by you.

DRAKE'S CYCLOPEDIA OF RADIO AND ELECTRONICS, by H. P. Manly. Cloth covers, size 6x9", 1050 pages, 1080 illustrations. New 1932 Edition. Price **\$6.00**
The largest work of its kind ever put together; a standby for every radio man.

RADIO TROUBLE SHOOTING, by Ennor R. Ham. E.E. Flexible covers, size 6x9", 323 pages, 257 illustrations. Price **\$3.00**
An intensely practical handbook for all radio service men and operators. Up-to-date in every respect.

FUNDAMENTALS OF RADIO, by R. R. Ramsey, Professor of Physics, Indiana University. Cloth covers, size 9 1/2 x 6", 372 pages, illustrated. Price prepaid **\$3.50**
The backbone of the radio art. This book gives you the foundation on radio from A to Z.

OFFICIAL RADIO SERVICE MANUAL, Volume I, by Hugo Gernsback and Clyde Fitch. Flexible loose-leaf binder, size 9x12", over 2,000 illustrations, 650 pages. COMPLETE WITH SIX SUPPLEMENTS. Price prepaid **\$4.50**
The Service Man's Bible. Greatest book ever published on the subject. Contains all old circuits of every imaginable commercial radio set up to 1931.

OFFICIAL RADIO SERVICE MANUAL, Volume II, by Hugo Gernsback, C. E. Denton and F. H. W. Nason, with 1932 Free Supplements, 1000 pages, 2000 illustrations. Flexible Loose-leaf Binder, size 9x12". Price prepaid **\$4.00**
The talk of the radio industry. This marvelous volume contains everything in radio, circuits, and radio developments, for 1932. Not a line of duplication between 1931 and 1932 volumes. (Vol. I and Vol. 2.)

ELEMENTS OF RADIO COMMUNICATION, by Professor John H. Morecroft. Cloth covers, size 9x6", 270 pages, 170 illustrations. Price **\$3.00**
An authoritative volume embracing every imaginable phase in radio communication.

RADIO SERVICE MAN'S HANDY-BOOK WITH ADDENDA DATA SHEETS. Flexible covers, size 9x12", 200 pages, 400 illustrations. Price prepaid **\$1.95**
The Service Man's standby. Contains the latest practical information on radio servicing.

RADIO TELEGRAPHY AND TELEPHONY, by R. L. Duncan and C. E. Drew. (New Edition.) Cloth covers, size 9 1/2 x 6", 550 pages, 468 illustrations. Price **\$7.50**
Everything from Ohm's Law to vacuum tubes and detectors, to oscillographs and radio compasses thoroughly treated in this great book.

PRACTICAL RADIO CONSTRUCTION AND REPAIRING, by J. A. Moyer, S.B., A.M. and J. F. Wostrel. Cloth covers, size 8x5", 351 pages, 163 illustrations. Price **\$2.50**
A handbook that every radio set tester and general student must have. The diagrams alone are worth the price of the book.

PRACTICAL RADIO—INCLUDING THE TESTING OF RADIO RECEIVING SETS, by James A. Moyer, S.B., A.M. and John F. Wostrel. Cloth covers, size 8x5", 378 pages, 223 illustrations. Price **\$2.50**
The title gives the story. Everything from crystal sets to the latest multi-tube receiver, and how they work.

RADIO RECEIVING TUBES, by Moyer and Wostrel. Cloth covers, size 7 1/2 x 5 1/2", 298 pages, 181 illustrations. Price **\$2.50**
One of the finest books on vacuum tubes. Everything worthwhile on the subject treated in a masterful manner.

HOW TO PASS U. S. GOVERNMENT RADIO LICENSE EXAMINATIONS, by R. L. Duncan and C. E. Drew. Flexible covers, size 9 1/2 x 7", 170 pages, 92 illustrations, appendix. Price **\$2.00**
The most important book on the subject ever published. Gives every conceivable angle which will help you to pass a radio license examination successfully.

PRINCIPLES OF RADIO, by Keith Henney, M.A. Cloth covers, size 8x5 1/2", 478 pages, 308 illustrations. Price **\$3.50**
A marvelously written textbook with the latest radio techniques, including screen grid and pentode, amplifiers, etc.

PHOTOCELLS AND THEIR APPLICATION, by V. E. Zworykin, E.E., Ph.D. and E. D. Wilson, Ph.D. Cloth covers, size 5 1/2 x 8", 210 pages, 97 illustrations. Price **\$2.50**
Get in on this coming art. Book covers everything on the subject important in radio, talking pictures, television, etc.

RADIO TRAFFIC MANUAL AND OPERATING REGULATIONS, by R. L. Duncan and C. E. Drew. Flexible covers, size 9x6", 67 pages, 186 pages. Price **\$2.00**
A live wire book for all radio amateurs, including how to learn code, abbreviations, International Radiotelegraph Convention, Radio Act of 1927, etc.

PRINCIPLES OF RADIO COMMUNICATION, by J. H. Morecroft, Prof. of Electrical Engineering, Columbia University. Cloth covers, size 9 1/2 x 6", 988 pages, profusely illustrated. Price **\$7.50**
THE radio classic, by the dean of radio. Covers entire radio art as does no other book.

EXPERIMENTAL RADIO, by R. R. Ramsey, Prof. of Physics, Indiana University. Cloth covers, size 7 1/2 x 5 1/2", 256 pages, 168 illustrations. Price, postpaid **\$2.75**
A marvelous book for the experimenter. Experiments galore in easy comprehensible language.

FUNDAMENTAL PRINCIPLES OF RADIO, by Louis Martin, B.S. Stiff Paper covers, size 6x9", 68 pages, 85 illustrations. Price **50c** prepaid
Just what the title says, but it gives you the HOW and WHY of radio in plain English. THE book for beginners.

MODERN VACUUM TUBES and How They Work, by "Bob" Hertzberg. Stiff Paper covers, size 6x9", 68 pages, 150 illustrations. Price, prepaid **50c**
Just published. This important book covers the art as does no other book. Describes all the latest tubes, including the "Triple Twin".

HUGO GERNSBACK
EDITOR

APRIL
1932



H. WINFIELD SECOR
MANAGING EDITOR

VOLUME II
NUMBER 6

SHORT WAVE CRAFT Now a Monthly

By HUGO GERNSBACK

WITH the present issue, SHORT WAVE CRAFT rounds out its second and most successful year; and as a special third birthday present to our readers, SHORT WAVE CRAFT, with its next issue, will become a regular monthly magazine, instead of only bi-monthly.

Ever since the magazine was started, we have been beseeched by readers, in not only this country but, literally, every part of the world, to make the magazine a monthly; and we have published many letters to this effect in our columns.

Of late, the clamor by our readers has become so insistent that we felt it our duty to comply with the demand and issue the magazine regularly every thirty days. For this reason, the magazine hereafter will be published on the 15th of every month. Newsstand readers should get their copies about this time of the month at their newsstands; and subscribers also should get their magazine by mail about the same time in the United States, and somewhat later, of course, in foreign countries.

Tremendous Interest in Short Waves

It may be said that, at the present time, there is a tremendous amount of popular interest in short waves, not only in this country, but the world over. What with short-wave broadcasting whereby you can tune in stations thousands of miles away by the mere twist of a knob; when the air is full of "police reports" and the apprehension of criminals; when television, riding on short waves, is just around the corner—and not a very far corner at that—it is no wonder that SHORT WAVE CRAFT fulfills an important mission.

We have tried to make SHORT WAVE CRAFT the faithful reporter of all progress in short waves, from every point of the globe. It is probably the only magazine of its kind in print today which gives the reader the international developments in short waves, in such a comprehensive manner; and, with your support, we hope to make SHORT WAVE CRAFT even better during the coming years.

Our Promise for the Future

We may say, without undue immodesty, that if you have found SHORT WAVE CRAFT interesting and to your liking, up to now, you will find it vastly better in the future.

But, first of all, we wish to assure you that the magazine will remain true to its slogan—it will remain "The Radio Experimenters' Magazine". By that is meant that it will not be a "high-brow", technical magazine, but

will feature more and more constructional articles of every kind in short waves, as the art progresses; and not only this, our platform will be that, if you see it in SHORT WAVE CRAFT, you will see it here FIRST. Even while the magazine was a bi-monthly, we still have managed, in the majority of cases, to have the latest developments FIRST; and it is our promise to you that SHORT WAVE CRAFT will have the latest technical set and constructional data, as well as new short wave developments FIRST, always.

This Is "YOUR" Magazine

We repeat what we have stated many times in this magazine: that this is YOUR magazine. We aim to publish only such articles as we know are desired by YOU. Strict attention is always paid to readers who wish us to print certain articles, and we go out of our way, frequently at considerable expense, to make such articles possible.

We are also happy to state that we have now surrounded ourselves by a competent staff of research experimenters who build "to our order" the latest short-wave sets, with the newest ideas incorporated therein. But it is up to you as a reader to tell us exactly the sort of articles you want; and you have our promise that anything, within reason, will be published by us in due time.

How You Can Help Make "SWC" Better

May we also remind you that the ultimate success of this publication is closely tied up with that of its advertisers? After all, it is the advertiser who makes the publication possible. No advertisers—no SHORT WAVE CRAFT! That is elementary and fundamental! May we point out to you that it is the duty of every reader to patronize SHORT WAVE CRAFT advertisers, who spend large amounts of money annually to bring to you the latest offerings in the short-wave field. The advertisers, therefore, deserve your confidence, just as much as the publication itself. Even if you do not need anything at this minute, it is still a good idea to write for advertisers' literature and acquaint yourself with their products, because you can never tell when you will need it—usually the need comes much sooner than you expect.

And in closing, the publishers wish to thank you for the fine support which you have given SHORT WAVE CRAFT during the past two years; and they, in turn, promise you the best and foremost magazine of its kind that it is possible to publish for you.

NEXT MONTH

SHORT WAVE CRAFT will present the most important announcement it ever made. It is the ONE thing you have been wanting for many years, something that will be welcomed wherever short wave enthusiasts live.

NEXT MONTH

A new \$500.00 Prize Contest—so simple that every radio experimenter and short wave constructor can join in it. The contest will run for six months.

SHORT WAVE CRAFT IS PUBLISHED ON THE 15th OF EVERY MONTH

THE NEXT ISSUE COMES OUT APRIL 15th

CAN WE RADIO MARS? "Yes - With 16 Inch Waves!"

Says - Dr. I. E. Mouromtseff
Westinghouse Research Engineer



IT would be maddening if the human eye and ear could see and hear all the sights and sounds that exist in the world.

This surprising and puzzling statement was made by Dr. I. E. Mouromtseff, research engineer of the Westinghouse Electric and Manufacturing Company, as he was discussing the new use of ultra-short radio waves as a means of communication.

L. W. Chubb, director of research, has just announced and demonstrated this simple and economical transmission of beam radio of a 42-centimeter (16.6 inches) wave of sufficient power to be heard from a loud-speaker.

Dr. Mouromtseff, who has had direct charge of the development work to give the idea practical application, points out that the difference between radio waves and light waves is quantitative, not qualitative. In other words, they are identical in every characteristic except wave length.

Short Waves and Light Closely Related

As a matter of fact he says there is more difference between long and short radio waves than there is between short radio waves and long light waves. To illustrate this, he says, the longest radio wave in use is 100,000,000 times as long as the shortest radio wave ever produced, whereas the shortest radio wave is only

16-inch wave transmitter in daily operation at Westinghouse laboratory, voice being carried over one mile.

1,000 times as long as the longest visible light ray.

Hence, he concludes, radio waves are merely "dark light".

Visible light waves, those between the long red and the short violet, constitute a very small percentage of the total range, just as audible sounds are a small fraction of all existing noises. Many of these have wave lengths or frequencies much too high or too low to set up cor-

responding vibrations in the human ear drum, the scientist explains.

"Nature has been kind to impose these limitations on our eyes and ears," he says. "Certainly all would be chaos and confusion if we could see and hear everything. On the other hand science would be seriously handicapped if it had not perfected instruments and apparatus to detect the invisible and inaudible.

Ultra-Short Waves May Reach Mars!

"At different times certain people have interested themselves in the possibilities of communication with possible inhabitants of Mars. If anything of this sort is ever to be accomplished, it will probably have to be done by means of ultra-short radio waves."

Some 25 years ago certain known facts of radio communication convinced Dr. A. E. Kennelly, professor of electrical engineering at Harvard, and Professor Oliver Heaviside, English scientist, that there must be a sort of cushion or atmospheric layer 100 or more miles from the earth's surface. This has since been known as the Kennelly-Heaviside layer.

"Of course it is a theory just as atoms and electrons were created by theory to explain certain phenomena," resumes Dr. Mouromtseff, "but we are certain that not only heat and light waves can penetrate something like the Heaviside layer, but

(Continued on page 428)

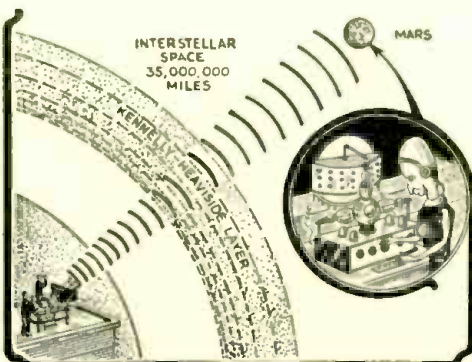

16-inch waves can penetrate ionized layer and reach Mars, it is now believed.

How New York City Uses SHORT WAVES to Trap Crooks!

By
"BOB" HERTZBERG



How three powerful short wave transmitters and 400 radio equipped cars help police apprehend criminals "on the spot."

ALTHOUGH it is the last of the large cities of the United States to adopt the radio alarm as a means of combating crime, New York is making up for its tardiness by doing a thoroughly fine job with its re-

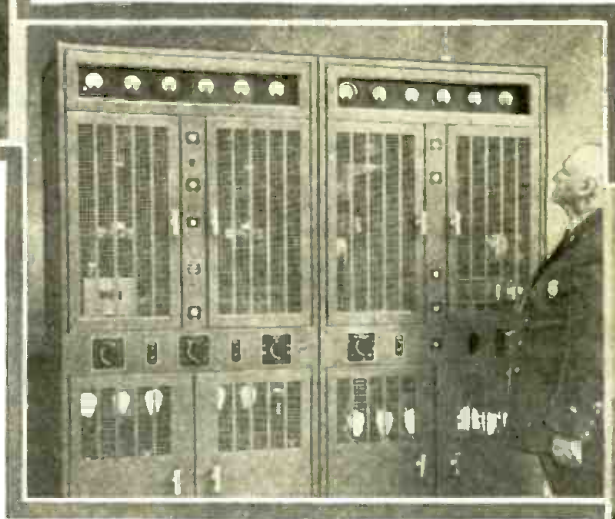

Top photo—Volume and sensitivity controls are on steering column; loud-speaker placed under dash or else ceiling; above—one of the S-W transmitters. Right—Talking to radio-equipped police cars via short waves.



Short wave super-het "car" receiver, loud-speaker and volume control unit.

cently-opened triple station hook-up. It is a big city, and its reputation for doing things in a big way is reflected in the size and scope of its new radio system.

Three separate transmitters, not merely one, are now broadcasting daily to a total of 400 radio-equipped cars. As the area of New York City is 320 square miles, this means an average of more than one car per square mile—surely a new record for radio directed patrol work.

Location of Three S-W Transmitters

The first broadcasting tests were made early in February of this year from the main transmitter, located in Police Headquarters at 240 Centre Street, Manhattan. They proved highly successful, and were soon followed by tests on the other

two transmitters, one located at the 40th Precinct station house at 138th Street and Alexander Avenue, in the Bronx, and the other at the 71st Precinct station house, located on Empire Boulevard, in Brooklyn. They provided many hours of interesting reception for short-wave listeners near and far.

All three transmitters operate on 2450 kilocycles. The headquarters outfit is capable of 1000 watts output, but is worked at 500 watts, the maximum permitted for police work by the Federal

Radio Commission. The other two are tuned up for their maximum output of 400 watts. The apparatus is of the latest

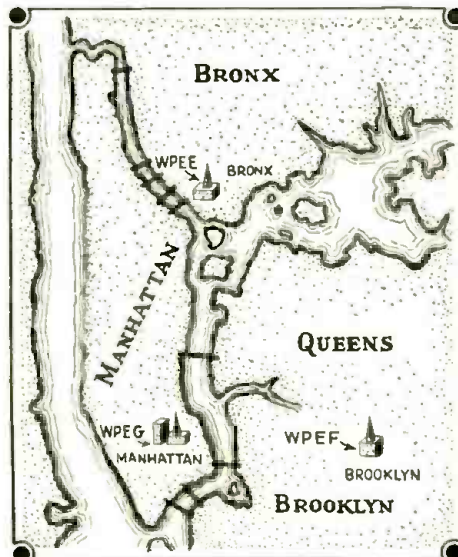

Three short wave "police" transmitting stations serve Greater New York.

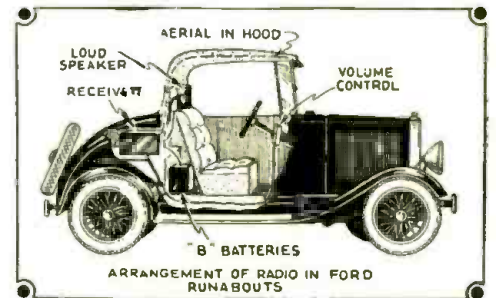

Typical S-W "receiver" installation on one of the 400 police cars.

Western Electric design, and is rugged and foolproof. The aerial for the 1000 watt station is a single wire, strung between the dome of Police Headquarters and the roof of the famous Police Academy, across the street. The aerials for the Bronx and Brooklyn outfits are supported by specially erected 65-foot wooden masts on the precinct buildings.

The call letters are WPEF for Brooklyn, WPEE for the Bronx, and WPEG for Manhattan.

Super-Het Receivers On Cars

The receiving sets selected for the police cars are seven-tube super-heterodynes with automatic volume control, manufactured by the American Bosch Magneto

(Continued on page 414)

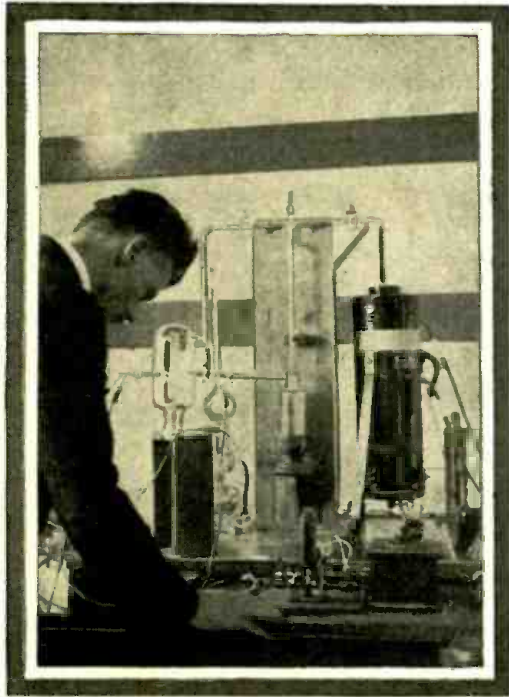

Pump used for investigating quartz oscillations in a vacuum.

How Radio
Research
Is Carried on
at the
**Heinrich
Hertz
Institute**
in
Berlin
by
Dr. Alfred Gradenwitz



High intensity glow lamp for the projection of television images.

VIBRATORY or oscillatory motion there exists everywhere, and an eternal up and down, to and fro, is characteristic of the course of history, the fate of the individual and all phenomena of nature: Cycles or waves—the former in the case of earth and moon, sun and stars, as well as of the ultimate particles (protons and electrons) that compose the innermost structures of atoms, and the latter in all the multitudinous phenomena studied by physicists—sound, heat, light and electricity. The swing of the pendulum thus controls the universe in the endless variety of all its manifestations. . . .

I recently called at a house in Berlin-Charlottenburg, a few minutes ride from the famous Engineering College, where *Vibration* is investigated, dissected and re-composed. Here all the fundamental

facts of physics, that constitute the very basis of both science and engineering, are put to searching tests and examined mathematically to elucidate their very nature, as far as it is given to us humans to ascertain the innermost nature of anything. As Thomas A. Edison once said—"I doubt whether we really understand one one-hundredth of one per cent about anything."

Vibrations in their most popular form are those electric waves upon which modern radio has been developed. This is why the Institute given up to wave research is named the Heinrich Hertz Institute, after the man who discovered these waves and, by so doing, laid the basis of our present-day radio science.

There is an undoubted advantage in dealing with all phenomena of vibration from a common point of view, rather

than investigating the same process over and over again in its various fields of engineering application. The intricate phenomena that take place in an electric power transmission line, in a telegraph cable, a telephone line, the crank-shaft of an airplane engine, in a radio set, in connection with a talking film, in the annoying street noises and traffic vibrations which spread into the interior of buildings—all these seemingly different phenomena are found after all to obey similar or identical laws, so that results in one field can often be profitably applied to some other field. In fact, this practice proves a wise economy.

The Heinrich Hertz Institute of *Wave Research* comprises the following five sections: (1) General Electrical Phenomena, (2) Telegraphy and Telephone
(Continued on page 429)

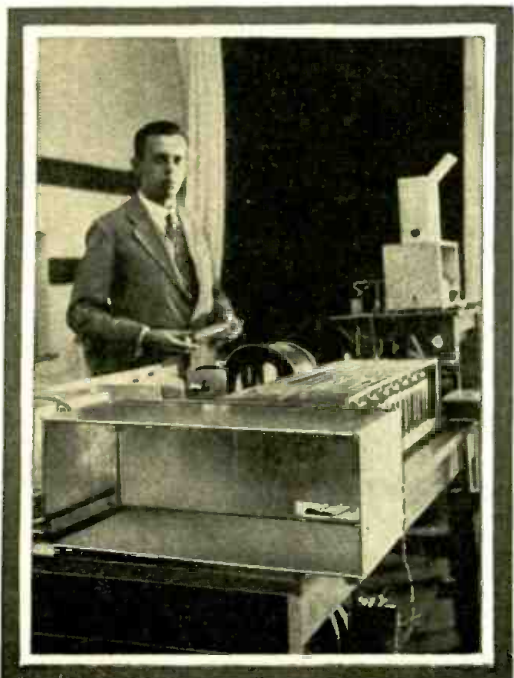

Left—Apparatus used for accurately ascertaining frequencies in the short wave range. A standard quartz crystal having been excited in its upper harmonics, interference is produced with the frequency to be measured.

Vibratory research is centralized in one grandiose laboratory, as Dr. Gradenwitz explains. Acoustical, as well as mechanical and electrical vibrations of every description are studied and analyzed by the very latest methods in this famous institute. Even the ultra-short waves and television are being investigated with the aid of the newest instruments.

Right: Cathode ray television tube apparatus for making laboratory investigations.



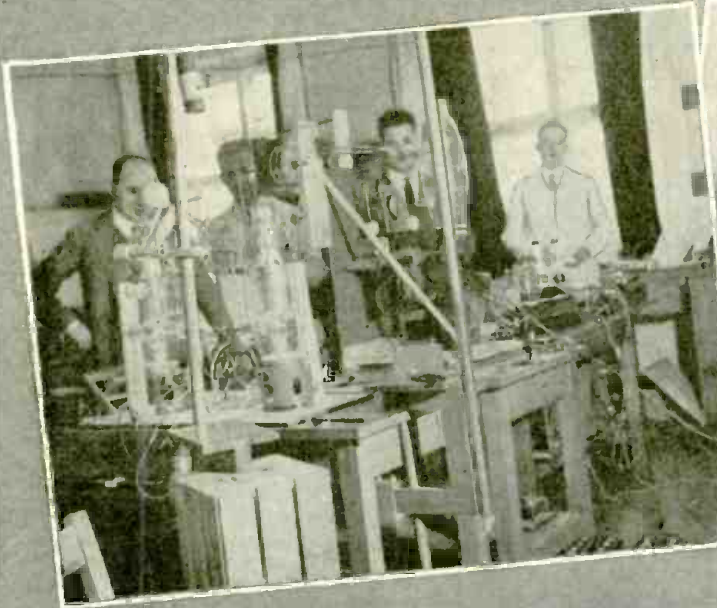

10-meter S-W apparatus used to test field intensities.

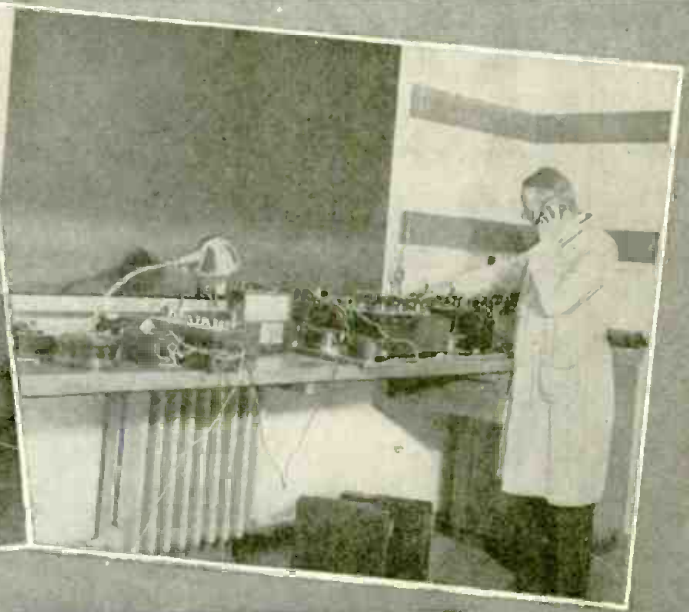

Measuring characteristics of telephone cables.

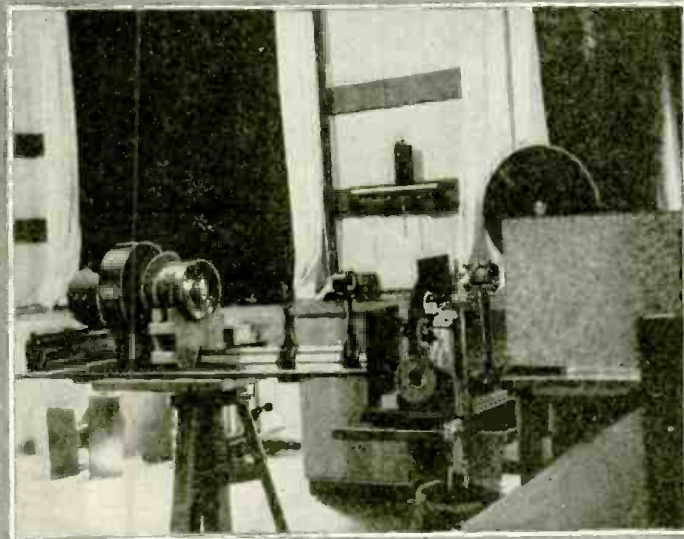

Television transmitter, scanner, photo-cell and amplifier.

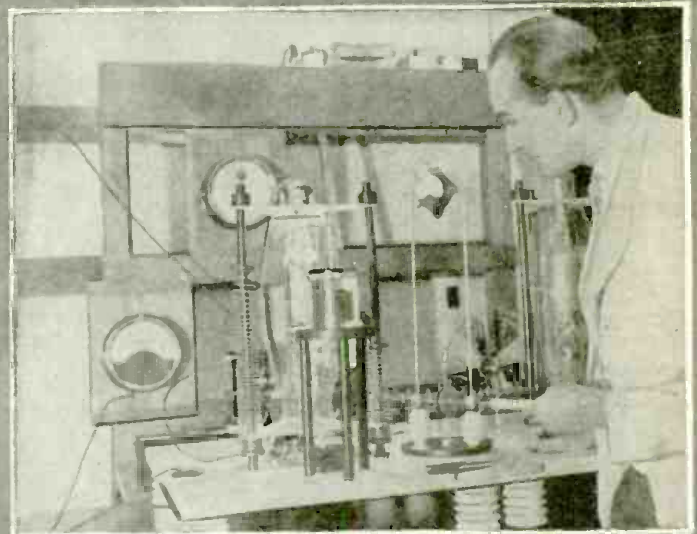

3-meter transmitter used for physiological tests.

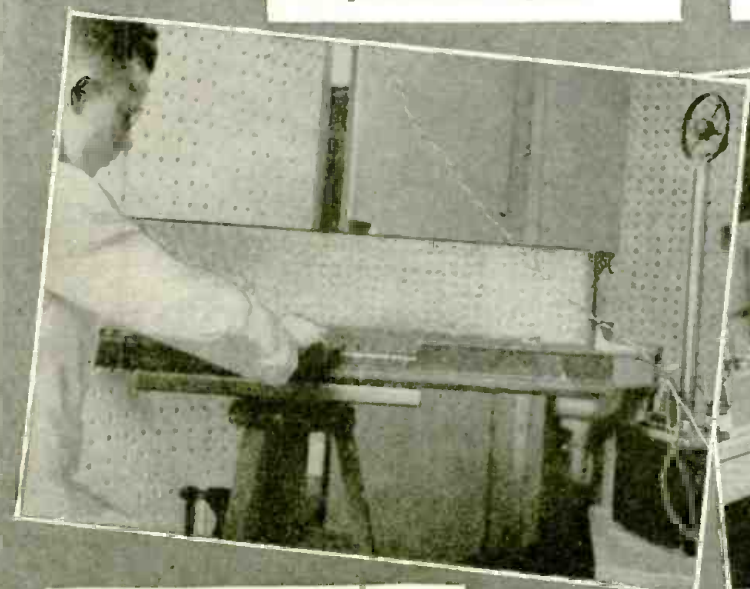

Highly "damped" room used for acoustic tests.

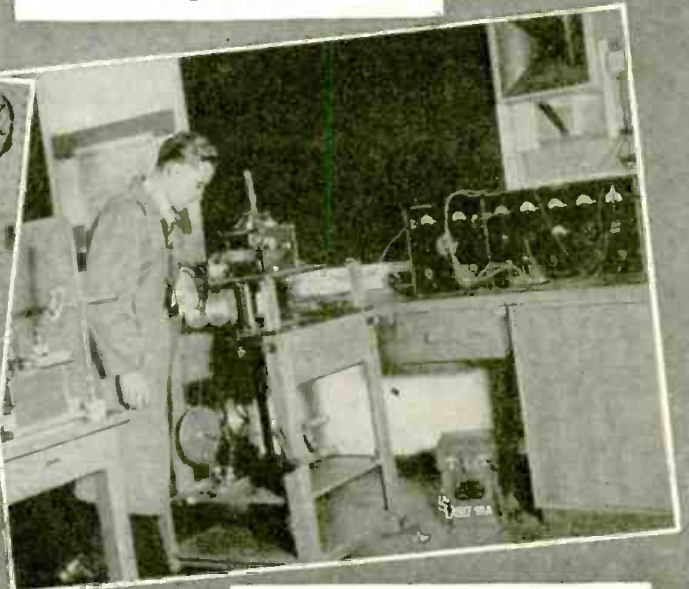

Sound analysis apparatus with oscillograph recorder.

2 R.F. PENTODE

SHORT WAVE RECEIVER

By CLIFFORD E. DENTON and H. W. SECOR

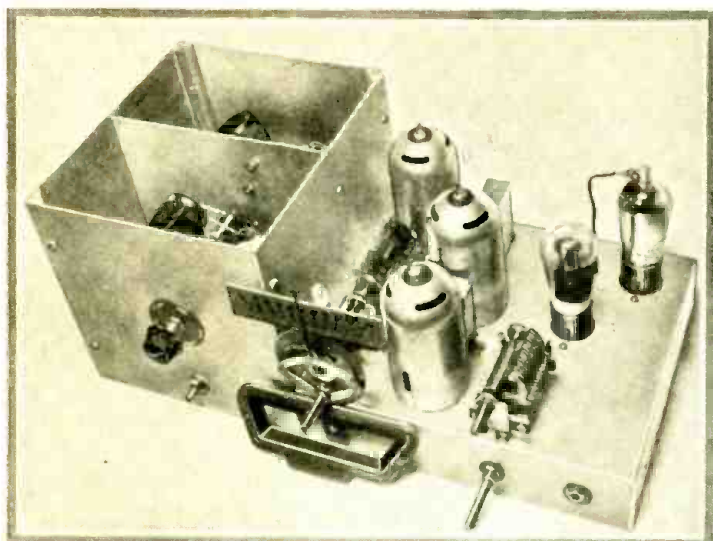

Front view of two R.F. pentode short wave receiver, which has regenerative detector stage, also two audio stages with pentode output tube.

Ten to two hundred meters—all the short waves—at a twist of the wrist, and with two stages of “working” radio-frequency amplification to boot. This receiver incorporates the very latest ideas in S-W receivers: Multi-stage, pentode, R.F., plus regenerative detector, and resistance-coupled audio amplifier. 6.3-volt tubes are used on storage battery or “A” eliminator. The new '39 R.F. pentodes give a “signal wallop” you won't forget!

TUNED radio-frequency amplification on short waves has been a topic of conversation for some time. The main drawback has been the difficulty of achieving a high degree of amplification along with the ease of single-dial control. The new six-volt radio-frequency pentodes are a distinct step forward in tube design and, because

of their low internal capacities, are the best tubes available for short-wave radio frequency amplification today.

This new receiver has two stages of tuned radio frequency, single-dial tuning, and a new and novel method of simultaneous switching for the various wavelength ranges or bands.

These coils were developed in the laboratories of the Best Mfg. Co., to the specifications of the authors; and, due to the clever design which was worked out by the “Best” engineers, the coils are a distinct success. The use of the five interlocked switches provides coils of the proper L-C (inductance-capacity) ratio for use over the various bands.

The reader will note the use of the

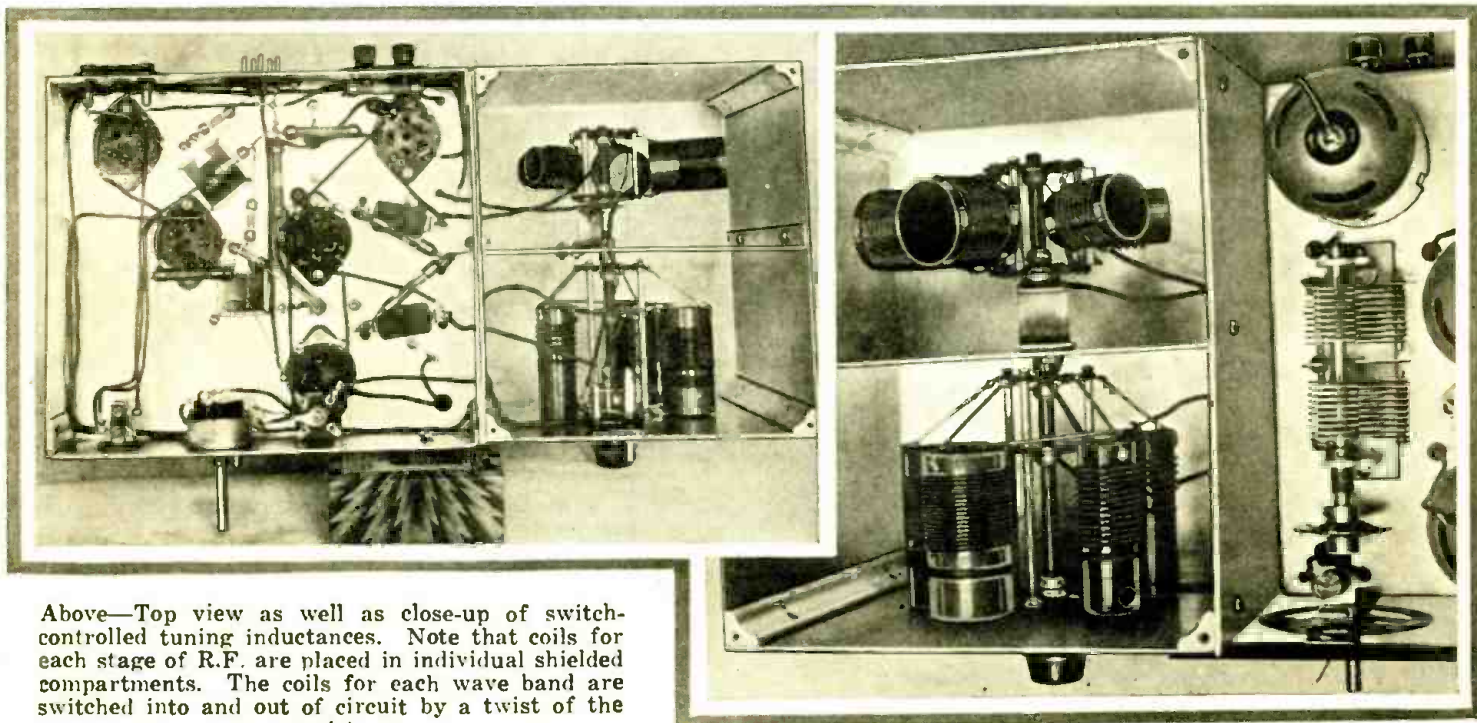

Above—Top view as well as close-up of switch-controlled tuning inductances. Note that coils for each stage of R.F. are placed in individual shielded compartments. The coils for each wave band are switched into and out of circuit by a twist of the wrist.

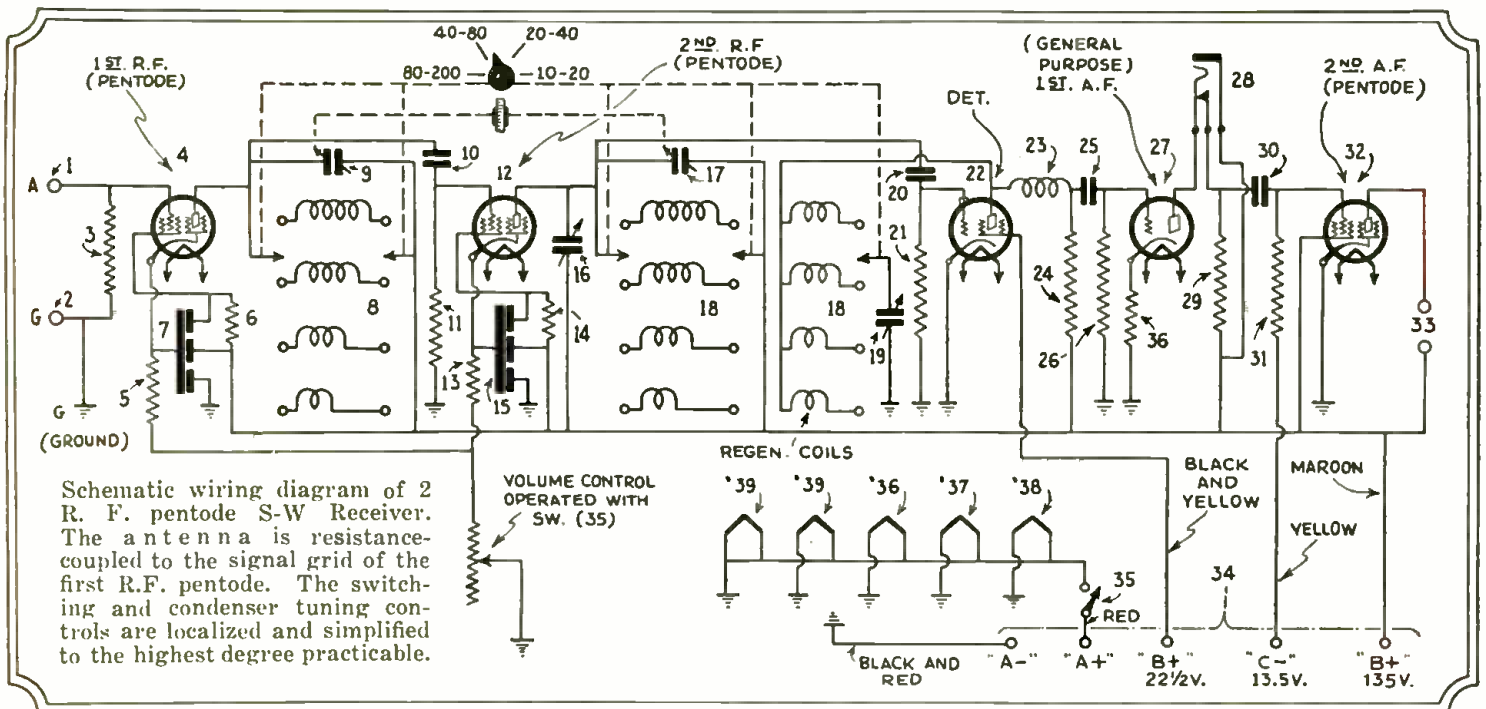

new variable-mu radio-frequency pentodes of the ER 239 type (also R.C.A. 239). These tubes show themselves to be one of the products of the tube laboratories which will receive much attention from the designers of the receivers which will be seen in the near future.

The authors at this point feel that mention should be made of the fact that they are indebted to the Best Mfg. Co. and the Eveready-Raytheon Co., for their kind assistance, which made this receiver possible.

This receiver presents a new step in shortwave design, incorporating tuned radio frequency with gain and stability, plus the *selectivity* which is so often lacking in the average short-wave receiver.

The Circuit

The circuit of this receiver—at first glance, seems extremely conventional. It is, but the idea behind the development was, not to try to present something new in circuit design, but to use a standard circuit and fit into these circuits the components which would enable the builder to obtain the maximum results. Needless to say, all of the parts are obtainable in the open market in New York City; so that no trouble should be experienced in collecting the material required to build the set.

The radio-frequency stages are of the *tuned-plate* type and, with a tuning condenser which has an isolantite base, it is not necessary to insulate the rotor from the chassis. It is important to note that the rotor shaft of the condenser should not “ground” through the tuning dial; use the flexible coupling.

The detector is the standard leaky-grid type, using a ER-236 screen-grid tube with condenser control of regeneration.

Resistance coupling is used throughout the audio system, which has a low-impedance tube in the first stage and a pentode in the output circuit.

The phone jack is handy for tuning in distance, and its use in the plate circuit of the first audio stage does not cause a change in any of the preceding stages.

All of the tubes are of the six-volt type, and operate directly from a storage

battery or any standard “A”-eliminator.

A 75,000-ohm variable resistor is used in the cathode circuits of the radio frequency tubes as a volume control. This, in conjunction with the ER-239s (or R.C.A. 239's), permits exceptional control of the radio frequency gain.

Mechanical Layout

Starting at the left, when looking at the front of the receiver, one finds the wave-band “selector switch” with the vernier tuning condenser mounted right below it. In the center is placed the master tuning control, using the new type full-vision dial so popular today. The regeneration control and the radio-frequency volume control are placed at the right of the panel. The phone jack is handy and does not complicate the receiver at all and is worth putting in.

Looking down on the chassis, the big box shield can be easily identified. Ad-

acent to the coil shield we find the master tuning control. Behind the dual condenser we find the first radio-frequency tube. The second radio-frequency tube stands near the tuning condenser between the two small rectangular boxes. These boxes by the way contain three 0.1-mf. condensers, used for bypassing.

The detector socket is near the tuning control, toward the front of the panel; and the condenser on the right of the detector tube shield is the regeneration control. The first audio stage is in a line with the second radio-frequency tube, but over toward the right. The power-stage socket is in line with the first R.F. socket, but located at the opposite end of the chassis.

On the rear of the chassis, the antenna-ground posts, the battery cable male receptacle and the loudspeaker twin-jacks complete the layout.

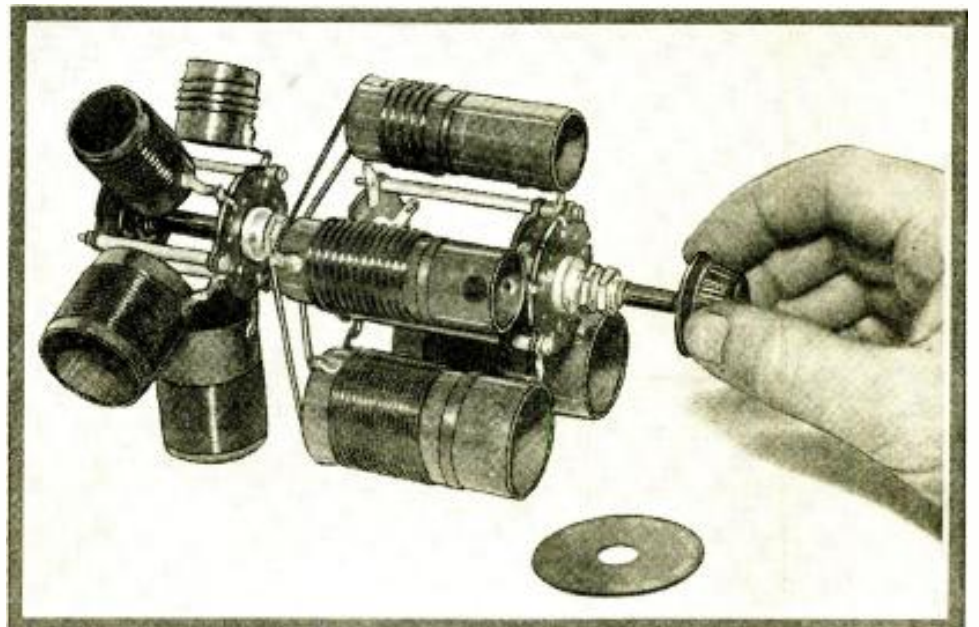

Close-up view of the “Best” tuning inductances and switch assembly built at the suggestion of the authors. The 4-point switches cover all the bands, 10 to 200 meters.

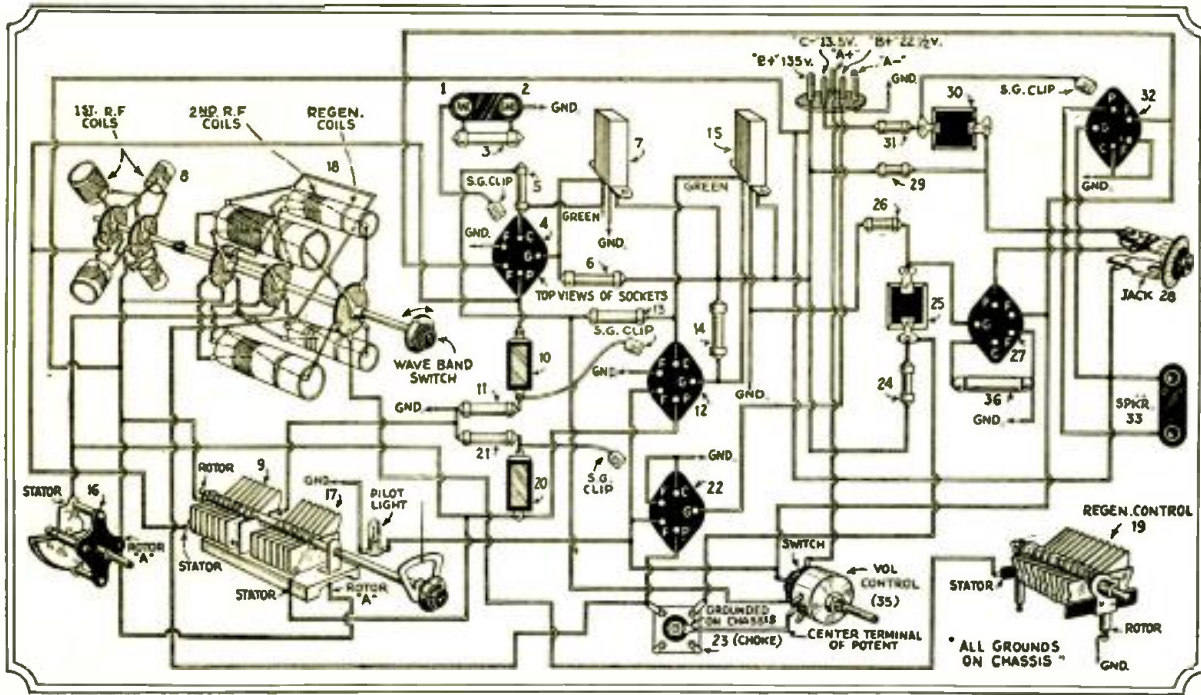

For those not used to wiring a set from the schematic circuit diagram this special "physical" diagram has been prepared by the editors. Insulated wire is mostly used in wiring sets today.

The final adjustment will be that of the radio-frequency gain control for maximum or required radio-frequency gain.

Once the set has been adjusted, the same settings hold over considerable portions of the tuning range and the only necessary controls are the master tuning dial and the volume control for voice reception (with

Assembly and Wiring

Obtain the aluminum box and chassis as specified in the parts list, or make it from data in drawings. The chassis can be obtained completely drilled and folded. Do not bolt the box shield to the chassis until most of the wiring has been completed on the chassis proper.

Mount the sockets, tube shields, tuning condensers, etc., as shown in the photographs and wire in all of the grid and plate leads close to the chassis.

The only parts to be mounted in the box shield are the tuning inductances, with their switches and the trimming condenser.

The leads running between the two partitions should be soldered to the tuning condensers and other points of contact, and left long enough so that the connections to the switches may be made after the box shield and the chassis is bolted together.

The radio-frequency choke is fastened by a bolt through the detector-socket mounting hole. All other small pieces of equipment are held in place by the wiring and, as the wiring is done, the parts should be soldered firmly into place.

Anyone at all familiar with wiring and capable of reading circuit diagrams will be able to build this five-tube set in record time, after the aluminum box and chassis is drilled and folded.

Note that, wherever a wire goes through the chassis, an eyelet has been fastened in, to minimize the danger of the wire's fraying and shorting to the aluminum frame.

Operation

The operation of the receiver may seem complicated at first, but is not so. After the batteries have been connected as shown in the diagram, turn the radio-frequency volume control full on; this closes the filament circuit. Wait a short time for the tubes to heat up.

Select the waveband to which you want to listen by moving the band selector switch to the proper point, as shown on the indicator furnished with the coils.

Turn the regeneration control knob and, if the receiver does not give the familiar response, reverse the leads to

the feedback coils on the larger tuning unit.

If the detector oscillates, turn the master tuning condenser dial until a voice or telegraph signal is heard. Adjust the

a slight readjustment for C.W. signals.

Within the next few months many experimenters will find that the ideas embodied in this receiver will find their way into every-day practice.

The authors will be glad to answer any questions about this receiver, provided the customary self-addressed and stamped envelope is sent along with the questions.

Parts List

- 1 Eby Antenna Ground Post (1, 12).
- 3 International 1-watt Resistors (3, 6, 14), (50,000 ohms each).
- 2 Eby Wafer Sockets, '39 type (4, 12).
- 1 Eby Wafer Socket, '36 type (22).
- 1 Eby Wafer Socket, '37 type (27).
- 1 Eby Wafer Socket, '38 type (32).
- 1 Hammarlund Dual Condenser, MDC-140M (140 mmf. each section) (9, 17).
- 1 Hammarlund Condenser, MC-250M (260 mmf.) (19).
- 3 Hammarlund Tube Shields.
- 2 Blan By-Pass Condensers, triple 0.1-mf. (7, 15).
- 2 International 1-watt Resistors, 500-ohm. (5, 13).

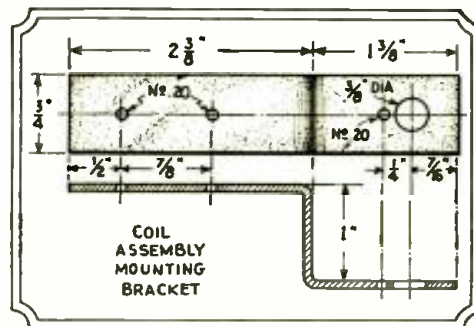

Detail of coil assembly mounting bracket fitted inside coil shield compartment.

trimming condenser (which is mounted in the coil-shield box) for maximum response.

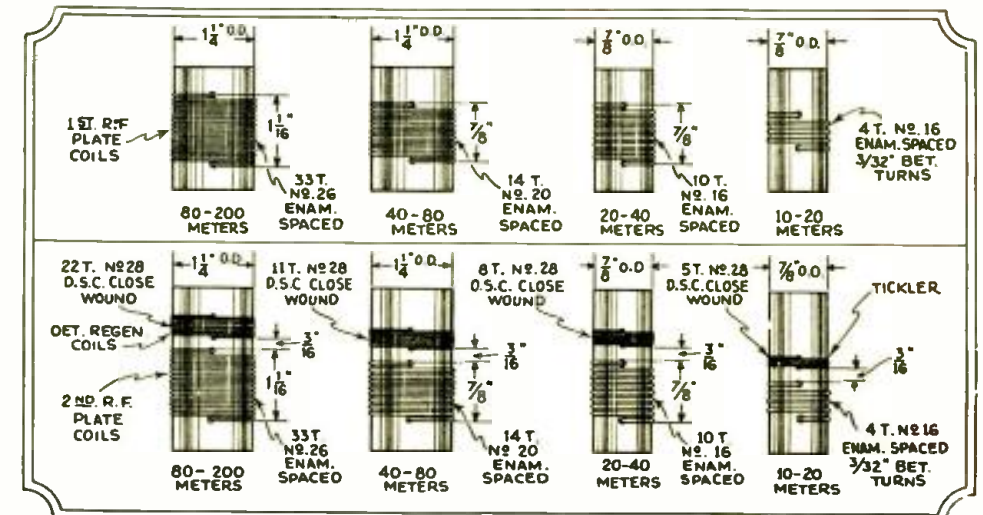

For those who "wind their own" we give above the necessary data for winding all the tuning inductances.

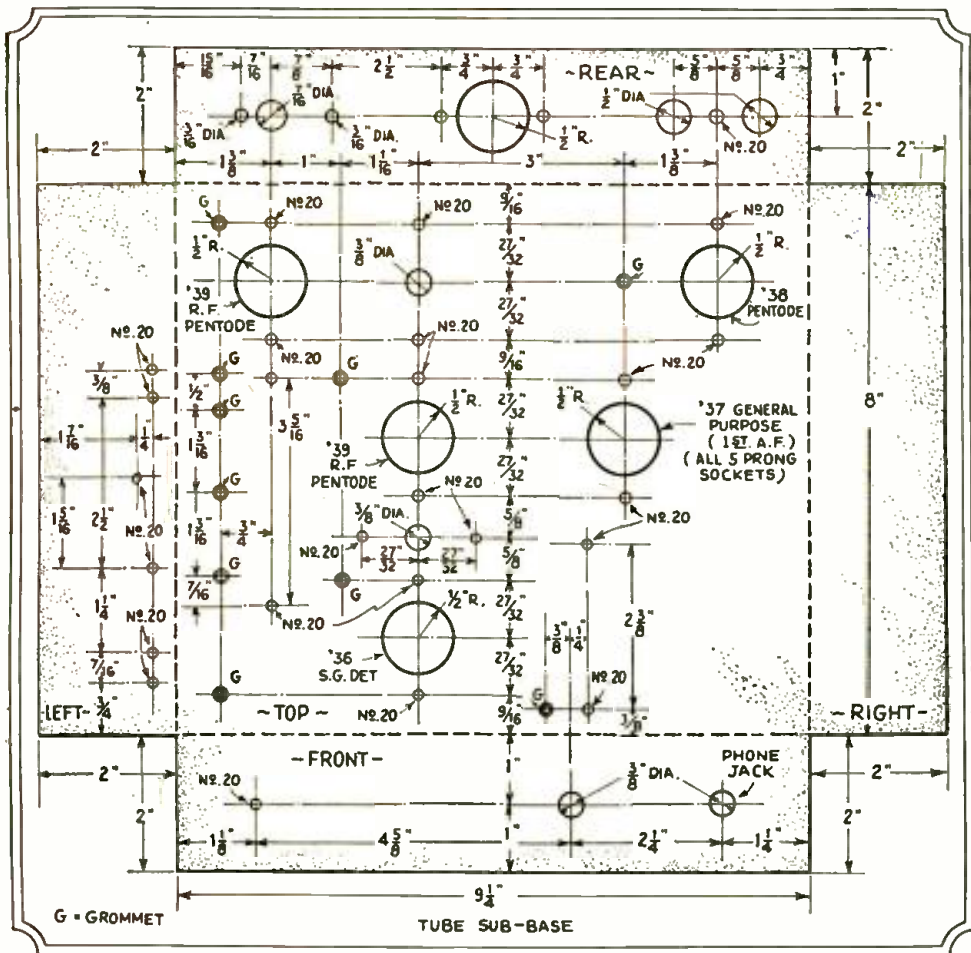

Above we have full detailed layout drawing for the tube and condenser sub-base for the 2 R.F. pentode receiver. The front and rear as well as the two sides, are bent down after drilling.

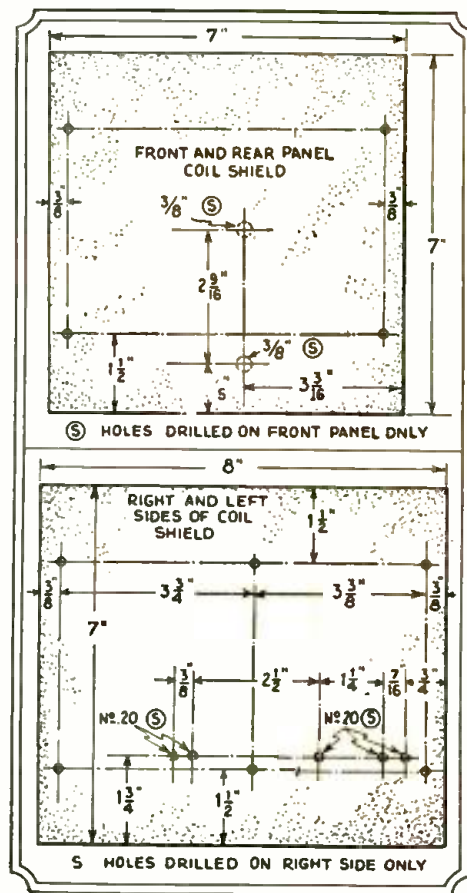

The two drawings above show how to layout and drill the front and rear as well as the two sides of the aluminum "coil" compartment.

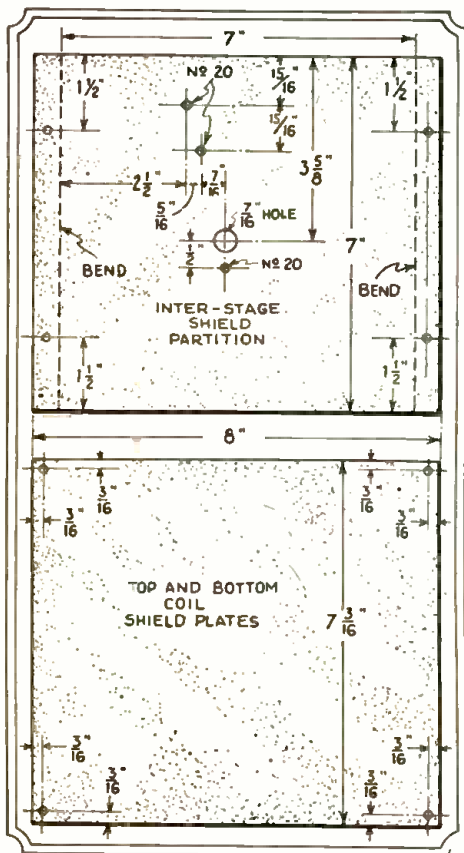

Above we have dimensions for the top and bottom of the coil shield compartment and also the inter-stage shield

- 1 Electrad Volume Control RI-202P (35) with power switch.
- 1 Crowe Tuning Dial.
- 1 "Best" Mfg. Co., Multi-Range Inductance Unit (8).
- 1 "Best" Mfg. Co., Multi-tuner Regenerator Unit (18).
- 1 Pilot 5-Plate Midget Condenser with Insulating Washers (16).
- 2 Illini Mica Condensers, 125 mmf. (10, 20).
- 1 Pilotohm 3 meg. (21).
- 1 Pilotohm 3 meg. (11).
- 1 Blan "Best" Tuner Shield, drilled and folded, with coil mounting brackets.
- 1 Blan R.F. Choke.
- 1 Blan Flexible Coupler, complete with extension shaft and reducing bushing.
- 2 Dubilier .015-mf. Mica Metal-Bound Condensers (25, 30).
- 3 International Resistors, one-half watt, 0.25-meg. (24, 26, 31).
- 1 International Resistor, one-half watt, 0.1-meg. (29).
- 1 Eby Speaker Twin Jack (33).
- 1 Frost Closed-Circuit Jack, with insulating washers (28).
- 1 International Resistor, 1-watt, 2,500-ohm. (36).
- 1 Eby 5-Prong Male-Type Wafer Socket, with female plug and cable (34).
- 1 Grid-Grip Screen-Grid Clip.
- 9 Insulating Eyelets.
- Miscellaneous Nuts, Bolts, Soldering Lugs, etc.
- 20 ft. Rubber Covered Push-Back Wire.
- 1 Dial Lamp and Socket.

NEW DELFT RECEIVERS

THE Delft Radio Co. has again designed an entirely new line of short-wave receivers having all the latest features and circuit improvements. Sets are now available at a low price which have an unusually fine appearance, as they use a new metal chassis instead of cheap baseboards. All the latest sets use screen-grid and pentode tubes.

Incorporating the newest tubes and designing for all-around efficiency, very good satisfaction is now obtained from their new sets. Reception is enjoyed from stations all over the world on a small set, and using only a small number of tubes.

Besides the "wavemeters", which are finding their way into the homes of many experimenters in all parts of the world, and to those who wish to locate foreign stations easily, Delft manufacturers a full line of short wave receivers and transmitters, all with the latest features. A light weight portable set is also manufactured; this has a large summer sale.

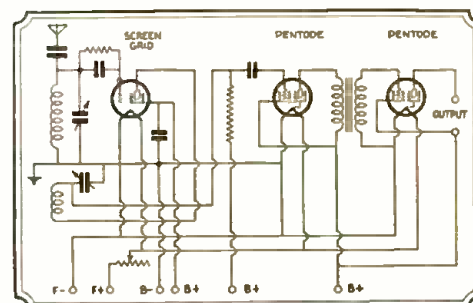

Diagram of new Delft 3-tube receiver.

A Practical 5 METER PHONE TRANSMITTER

By R. L. TEDESCO (W1CAC) and A. TEDESCO (W1BMB)

Amateur radio operators are now busy developing the 5-meter band; this article by two experts will prove both valuable and interesting. Suitable receivers are described elsewhere in this issue.



The five-meter phone transmitter set up and connected to aerial, data on which appears herewith.

rod of each condenser is assembled a small bracket, bent up, and carrying a G.R. type 274 bushing, which in turn forms a socket and supporting member for the plug-in plate coil. This plate coil is made of a single turn of $\frac{3}{4}$ -inch copper tubing, 4 inches in diameter. A

Two carefully constructed radio-frequency chokes are necessary, the efficiency of the coils depending upon the care used in the construction. This prevents migration of R.F. voltages to other parts of the circuit, which causes detrimental results.

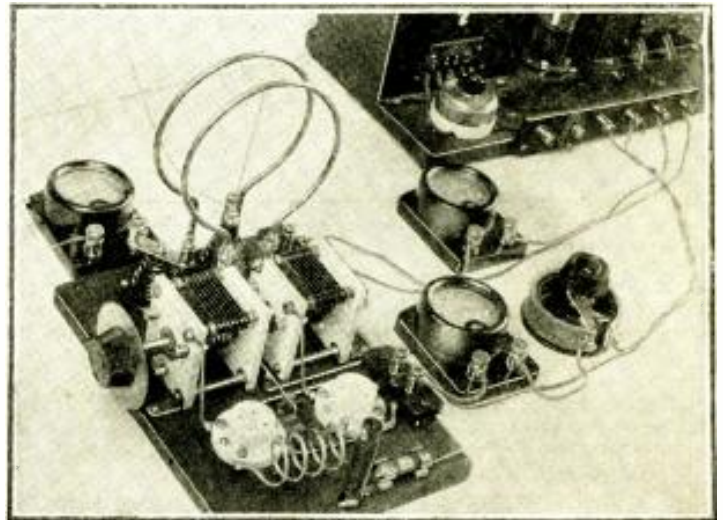

At Right: Close-up view of the five-meter transmitter, showing the neat workmanship and high quality of the parts used.

IN considering the advantageous features of five-meter operation, as against the other phone bands, the majority will agree that the ultra-high-frequency method of communication is to be preferred; in spite of the fact that it has its limitation in respect to the amount of distance that can be covered. However, no one has yet found what the possibilities are with very short-wave transmission. The very idea of tinkering with a new region of the short-wave spectrum stimulates a great desire and interest to find out about it. What real "dyed-in-the-wool" ham can refrain from that endeavor?

We know that the average ham is somewhat worried over the false impression that ultra-high-frequency oscillators are "tricky" to operate. This is true to a certain extent; but if the necessary precautions are observed, everything works out all right. An interesting article by J. J. Lamb, in the July, 1931, issue of *QST*, reveals a gold-mine of information regarding this work.

"Bread-Board" Assembly Used

As a "bread-board" assembly is the most convenient and economical, we will resort to that style of construction. Referring to Fig. 1, lay out the units as shown. The drawing is self-explanatory, so that no dimensional details need be given here. Since the success of this outfit depends upon a careful and symmetrical layout, it is necessary to adhere to the following design.

Mount all parts as rigidly as possible to insure decent mechanical rigidity. The condensers are General Radio type 538-50-mmf. each arranged in tandem, and with rotors connected by a common shaft of insulating material. On one stator

small hole is drilled at the exact center of this loop for the plate-voltage feed wire. At each end of the loop and plate-voltage feed wire, there is soldered a G.R. type 274-P plug. This assembly constitutes the main tuning unit of the oscillator.

An antenna-coupling coil is made similar to the plate coil, eliminating the voltage-feed wire. The supports for the antenna coupling coil consist of two G.R. type 260 cone insulators, upon which are mounted $\frac{1}{2}$ -inch straps 2 inches long, having a pair of G.R. type 138-V binding posts, which act as sockets for the plug-in antenna coil, and also as a means for connecting feeder wires from the antenna at the other end. Figure 1 shows this arrangement clearly. Two 4-prong tube sockets are mounted adjacent to the tuning unit, as shown, for supporting the grid coil and a center-tap resistor. The grid coil is made up of No. 10 copper wire, wound 1 inch in diameter; four turns being required to get an approximate five-meter coil. Since this coil is not tuned by a condenser, tuning is accomplished by elongating or compressing the coil as necessary, when adjusting the oscillator frequency. The ends of this grid coil are soldered directly to the grid terminal on the sockets. The grid return to this coil is connected at the exact center of the four turns and soldered.

R.F. Chokes—How Made

On a piece of hard rubber or bakelite tubing, wind 20 turns of No. 24 D.S.C. copper wire, and space the windings by winding two wires at one time, then removing one of the wires; thereby leaving a space between turns on the remaining coil. This spacing is important. One of the choke coils has a G.R. plug socket threaded into one end, thus making provisions for the plate-coil voltage-feed wire to plug into. This radio-frequency choke coil is mounted upright between plate and antenna coil as shown at "b" in Fig. 1. The other radio-frequency choke coil is mounted vertically, supported by the center-tap wire of the grid coil at one end, and is soldered directly to the fuse clip carrying the non-inductive 10,000-ohm resistor, which is in the "B—" lead. The center-tap filament resistor is inserted across the filament connections and, if the G.R. type 437 is used, the terminals are locked directly under the nuts of the filament terminals of the socket. Two pairs of binding posts are provided; one for filament connections, and the other for the plate-voltage supply. The "B—" post connects to the ground. All wiring should be done as per diagram, and special attention paid to symmetrical arrangement and rigidity.

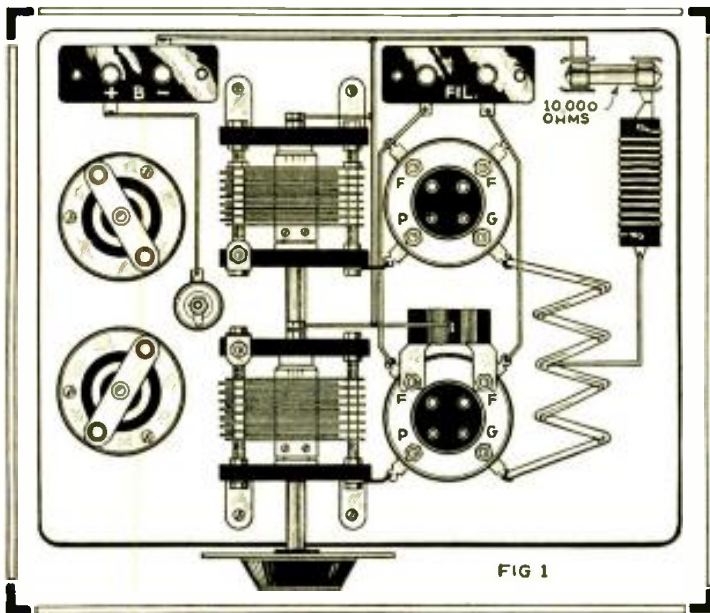

Fig. 1—Base-board layout of 5-meter phone transmitter, which it is advisable to follow.

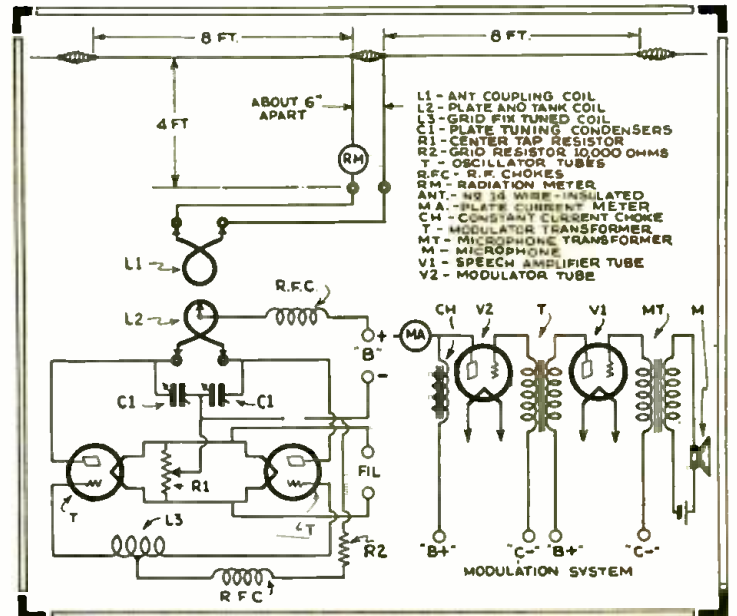

Fig. 2—Circuit diagram of 5-meter transmitter, with modulation amplifier and "mike" with battery.

The Antenna System for 5 Meters

After a careful examination of the circuit and assembly, the antenna system is next in order. The doublet type of antenna used in this case may be erected in the same room where the apparatus is installed. Two No. 12 wires, about 12 feet long, are arranged to extend upward for approximately 4 feet; and the remaining portion is bent at right angles to the upright portion, or in a horizontal position. (Refer to Fig. 2.) The parallel section is separated by a spreader about 6 inches long. The tuning of the antenna is accomplished by the proper separation of these feeder wires, which tends to add or subtract capacity. It is important to have the antenna tuned to the proper wave-length of the oscillator, to obtain the most effective transfer of energy to the radiating system.

Meters should be provided in the various parts of the circuits, to facilitate adjustment of the oscillator. The meters necessary are a radiation meter in one

of the "legs" of the feeders of the antenna system; a plate milliammeter in the "B+" of the plate supply; and an ammeter in the filament circuit to indicate the proper voltage on the filaments of the tubes.

Adjusting the Oscillator

The procedure for the adjustment of the oscillator is as follows: Apply the proper voltages both to filaments and plates and note reading of ammeter in tube circuit. For type '10 tubes as oscillators, the filament current should read about 2.5 amperes; the plate-current reading should be about 80-90 milliamperes with 550 volts on the plates of the tubes. If the circuit is not oscillating, an abnormal amount of plate current will be apparent. The maximum energy transfer from oscillator to the radiator system is about 400 mils. for normal operation. Tuning of the oscillator frequency is effected by the adjustment of

the main condenser, which is equipped with a dial.

Voice Modulation

If voice modulation is to be used, a modulation system will be necessary. This unit consists of a type '50 modulator tube, and the necessary speech amplifier, together with a microphone. The wiring diagram used is Fig. 2. The power supply for the modulator tube should be common to the oscillator and is fed through a modulation choke of about 30 henries. When speaking into the microphone, an increase in the feeder current should be apparent. This increase in the radiation is in direct proportion to the percentage of modulation. One should not, however, attempt to obtain too much modulation, or *frequency wobble* may be the result.

After a little experience with your own transmitter, you will gain the knowledge necessary to realize when you are operating efficiently.

Valuable Coil Winding Data

Octocoil Winding Data

To cover the short wave bands from 16 to 225 meters, 4 plug-in coils are used, each coil being 1½ inches in diameter and the turns or coil form being octo or 8-sided and not round as in most coils, with the turns supported only from the 8 respective ribs. These coils "L1" are designed for operation with a .00015-mf. variable condenser; the tickler is represented by "L2."

Color	Meter Range	No. of Turns, L1	No. of Turns, L2
Green	16-30	6	6
Brown	29-58	13	13
Blue	54-110	21	15
Red	103-225	54	27

Data on National "Short Wave" Coils for The Battery Type Short Wave Receiver

The secondary winding of the coils is shunted by 90 mmf. (.0009 mf.) variable condensers. Diameter of coil forms 1½ inches:

- No. 10 coils, covering from 9 to 15 meters:
 - Secondary 2 5/6 turns of No. 16 Enamel
 - Primary 1 5/6 turns of No. 34 Enamel
 - Tickler 3 turns of No. 32 Double Silk.

- No. 11 coils, covering from 14.5 to 25 meters:
 - Secondary 6¼ turns of No. 16 Enamel
 - Primary 3 5/6 turns of No. 34 Enamel
 - Tickler 3 turns of No. 32 Double Silk.
- No. 12 coils, covering from 23 to 41 meters:
 - Secondary 11 5/6 turns of No. 18 Enamel
 - Primary 7 5/6 turns of No. 34 Enamel
 - Tickler 3 turns of No. 32 Double Silk.
- No. 13 coils, covering from 40 to 70 meters:
 - Secondary 19 5/6 turns of No. 18 Enamel
 - Primary 12 5/6 turns of No. 34 Double Silk
 - Tickler 4 turns of No. 32 Double Silk.
- No. 14 coils, covering from 65 to 115 meters:
 - Secondary 34 5/6 turns of No. 24 Enamel
 - Primary 21 5/6 turns of No. 34 Double Cotton
 - Tickler 4 turns of No. 32 Double Silk.
- No. 15 coils, covering from 115 to 200 meters:
 - Secondary 62 5/6 turns of No. 28 Enamel
 - Primary 38 5/6 turns of No. 32 Double Silk
 - Tickler 5 turns of No. 32 Double Silk.

DESIGN OF COILS USED IN SHORT-WAVE RECEIVERS:

- Pilot "Super-Wasp": tuning capacities 160-mmf. (max.) in series with .01-mf., regeneration capacity 250 mmf.
 - Diameter of form, 1¼ inches.
 - Meters Antenna Detector Coupler Covered Coupler Grid Tickler (Approx.) Turns (Spaced ¼ in.)
 - 14.5-27.0 4¼ No.24DSC 3¼ No.24DSC 4 No.24DSC
 - 26.0-50.0 9¼ No.24DSC 7¼ No.24DSC 6 No.24DSC
 - 48-100 20¼ No.24DSC 17¼ No.24DSC 7 No.24DSC
 - 100-200 46¼ No.24DSC 45¼ No.24DSC 16 No.24DSC
- Hammarlund: for tuning capacities 125-mmf.; regeneration 100 mmf.

Diameter of form, 2 inches. Windings separated 1 turn.

Meters	Grid Coil Turns	Plate Coil Turns
14-24	3 No. 16 DSC	3 No. 16 DSC
22-40	7 No. 16 DSC	5 No. 16 DSC
35-65	15 No. 16 DSC	6 No. 16 DSC
60-110	24 No. 18 DSC	12 No. 18 DSC

No. 16 wire spaced 11 turns to inch: No. 18, 17 turns.

Variable primary of 6 two-inch turns, used with all coils, is 1 13/16 inches in diameter, hinged. Silver-Marshall "Midget": for 140-mmf. tuning capacities

Diameter of form 1 inch: primary (tickler) wound in slot. Forms threaded 39 turns to inch.

Meters:	Tuned Secondary Turns	Primary Turns
16-31	6¼	5 2/3
30-57	13¼	7 2/3
55-104	25½	12 1/3
103-195	46½	25 2/3

"Craft-Box" tube-base coils, home-made. Forms 1¼-inch. Tuning capacity 32-mmf. Regeneration capacity, same. Windings separated ¼-inch.

Meters	Tuned Secondary Turns	Tickler Turns
18-25	7 No. 28 DCC	7 No. 28 DCC
25-45	10 No. 28 DCC	10 No. 28 DCC
35-45	15 No. 28 DCC	14 No. 28 DCC
45-65	20 No. 28 DCC	18 No. 28 DCC
63-100	50 No. 28 DCC	50 No. 28 DCC

Demonstration With U. S. W. Transmitter on

THREE METERS

By DR. W. MOLLER

Dr. Moller needs no introduction to the ultra-short wave fraternity. The Editors consider themselves fortunate indeed to have the opportunity of presenting this specially prepared article, describing the very latest European developments in three meter transmitters and receivers.

SOME experiments with a small ultra-short wave transmitter are here described, which are above all of value to those amateurs who are interested in studying the physics of radio technology. Since the individual experiments are preëminently suitable for presentation purposes and demonstrate the essentials of the processes in question in a clear manner, they may also find consideration by the physics teachers in the schools.

The transmitter itself operates on the Reich principle, and the short wave between 2.50 and 3 meters is attained by an extensive reduction of the frequency-controlling parts of the tuned circuit. On principle it would be possible without difficulty to carry this reduction of the tuning elements still further and then to produce still shorter waves. Only this endeavor meets a natural limit, due to the fact that with decreasing wavelength at the same time also the power given out by the transmitter decreases very strongly in the case of waves shorter than two (2) meters. The field lying about the transmitter then becomes very weak and it causes considerable difficulties to demonstrate the field by simple means.

Building the Transmitter

The transmitter can be made without difficulty. Its construction follows the diagram of Fig. 1. As a transmitter tube there is used a special type: its



Fig. 4—The continuation of our work.

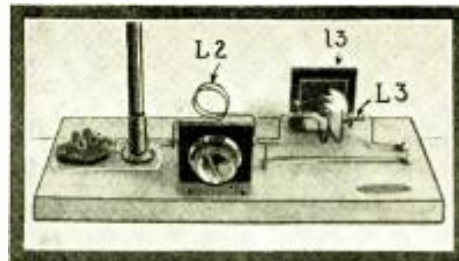

Fig. 3—The base-board with tube socket and filament current circuit.

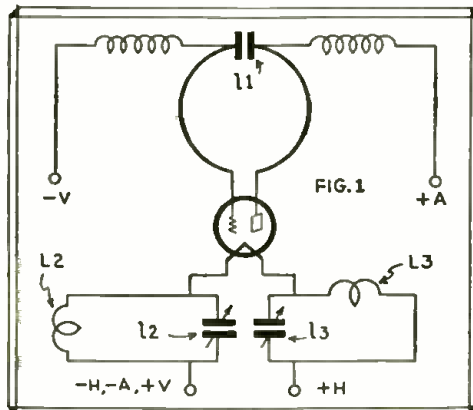

Fig. 1—Hook-up of the ultra-short wave transmitter.

grid and plate are not, as usually the case, connected with the socket; instead they are connected at the top of the tube to two terminals attached thereto. The data on the tube are: filament potential 4 volts, filament current 1 ampere, emission 400 milliamperes, plate D.C. potential 400 volts, magnification factor 4%, mutual conductance 2 milliamperes per volt, internal resistance 12,500 ohms.

The Oscillation Circuit

The oscillation circuit is supported by the tube itself. It consists of a single turn, whose ends we fasten to the grid and anode terminals. This turn represents the inductance of the oscillation circuit. Its capacity is the internal tube capacity between grid and anode. Above in the middle the coil is cut open and there a small block condenser L1 of 200 mmf. capacity is inserted. Since it lies at this place at the nodal point of the alternating potentials produced, it has no determining influence on the wave length. It merely serves the necessary purpose of keeping apart the operation potentials to be applied to grid and anode. Because therefore relatively large potential differences occur on its plates, we must not use just any block at all, particularly not one out of receiver hook-ups, since this will easily break through and then destroy the tube. The condenser must possess a testing voltage of at least five times the operation voltage. I have used a block with a dielectric of special glass. In order not to load the

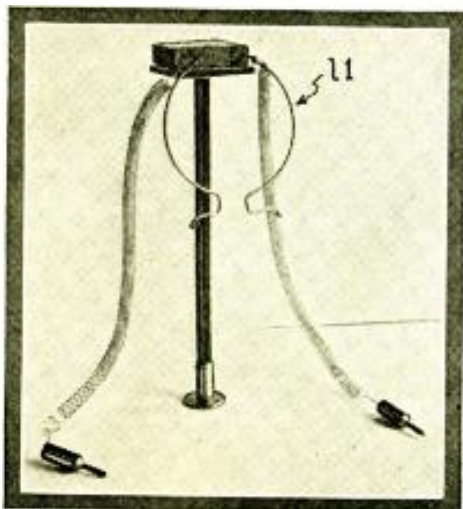

Fig. 2—The inductance of the oscillation circuit.



Fig. 5—Transmitter without a support for the block condenser.

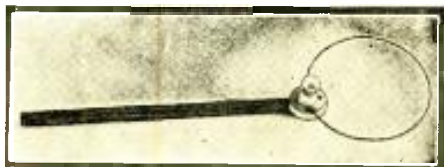

Fig. 6—The "oscillation indicator."

tube with its weight, it is supported by a special holder. Compare the photograph (Fig. 2). The operating potentials themselves must be conducted through small choke coils to the organs of the tube, in order to prevent a part of the high frequency power from getting in this way into the sources of potential, and so being lost. About 20 turns of stout copper wire with approximately 2.5 inches winding diameter would without a core give a perfectly satisfactory choke effect.

The filament wires are to be treated still more carefully, since even over them a great amount of oscillation power may be lost. Better still than choke coils are in this case stopper circuits, which, if tuned to the frequency produced, then always offer the greatest resistance to it.

Dr. Moller's article herewith is the equivalent of a college lecture on "ultra-short waves". Five elaborate experiments are described.

Corresponding to the ultra-short-wave, the tuning elements of the stopper circuits are also to be made of very small dimensions. Its capacity is a small rotary condenser (12 and 13) of .40 mmf. maximum capacity (neutrodon). The dimensions of the stopper circuit coils are: 3 turns of .8 inch diameter with No. 14 wire.

The photograph of Fig. 2 shows the wire loop fastened on a support. The plate lying up on the support carried the disruption proof block condenser, to whose poles the half turns and the choke coils are soldered. The tube itself is mounted with its socket on a small board about 28 cm. long and 14 cm. wide. This board carries the filament wires and the stopper circuits installed in them, as well as the support for the block condenser and inductance, L1. Fig. 3 shows the way I mounted the individual parts on

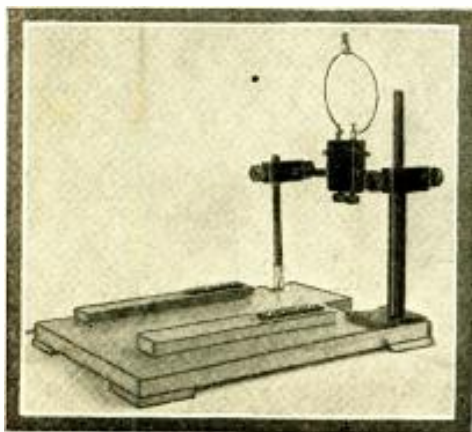

Fig. 7—The large base-board with sliding base.

this baseboard. One also sees the stopper circuits and observes that the axes of the coils of these circuits are turned at an angle of 90 degrees from each other. This measure has the purpose of preventing a magnetic coupling between the two circuits.

The continuation of our work is shown in the photograph of Fig. 4. The turn of copper wire (bent by us out of No. 32 wire) is already fastened to the tube. If this turn has a diameter of about 4 inches, the wave produced gets a length of about 3 meters. Attention may now be called to the shape of the little baseboard. The long edges are made oblique (and inclined a little toward each other) so that this board may later be put on a larger baseboard between two guiding slats, inclined toward each other and thus it may be moved as one slides a drawer.

The photograph of Fig. 5 simply gives a variation of the same set. Here the hypothesis is that the disruption-proof block condenser is available in so light a form that its weight does not endanger the tube.

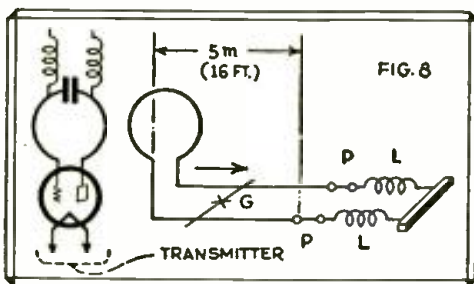

Fig. 8—The hook-up of the parallel wire system for measuring the wave length.



Fig. 10—The dipole antenna.

Experiments

Experiment 1.—If the operation potentials are applied to the tube, then in the oscillation circuit supported by the tube there result alternating currents of extraordinarily high frequency. Let us assume a wave length of 3 meters as proved (the exact determination of the wave length takes place in the second experiment), and there follows from the law that the speed of propagation is equal to *frequency times wavelength*;

$$3 \text{ times } 10^8 \text{ equals } n \times 3, \\ n \text{ having the value } 100,000,000.$$

Alternating currents of such high frequency have a very strong induction effect. To demonstrate this as clearly as possible in a simple experiment, we bend out of a No. 14 copper wire a turn 4 inches in diameter and fasten its ends to the terminals of the porcelain socket of a small flash-light bulb. The lamp socket is supported by a 10 inch stick of wood, as shown in Fig. 6. As soon as we hold this turn of wire in the vicinity of our oscillation circuit, the little lamp lights up brightly. With this we have available a very simple means of showing to others who are watching our experiments that the transmitter is operating. The apparatus of Fig. 6 is there-

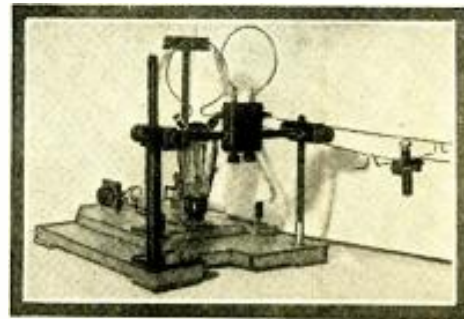

Fig. 9—The parallel wire system set up.

fore to serve mainly to demonstrate the oscillations. We will therefore call it the "oscillation indicator".

Experiment 2.—The determination of the wavelength by the parallel wire system. In Figs. 3, 4, and 5 there was simply shown the sliding board carrying the tube and oscillation circuit. The photo. Fig. 7, shows the large baseboard and the "rails" between which the sliding board runs, and at the same time the arrangement by which we will couple another system capable of oscillation

Ultra-short waves are engaging the attention of amateur and engineer alike. This article explains how 3-meter waves are transmitted and received.

with the transmitter tube. For this purpose we use two vertical supports of hard rubber, between which a horizontal strip of hard rubber is stretched. On this can be screwed a block of hard rubber, into which have been put suitable terminal contacts of brass.

Now we use this arrangement to construct an experimental apparatus, according to the hook-up shown in Fig. 8. There is put on the rubber block opposite to the oscillation circuit coil of the transmitter an equal large coil. See Fig. 9. The free ends of this turn are connected to two wires, stretched out horizontally

(Continued on page 415)

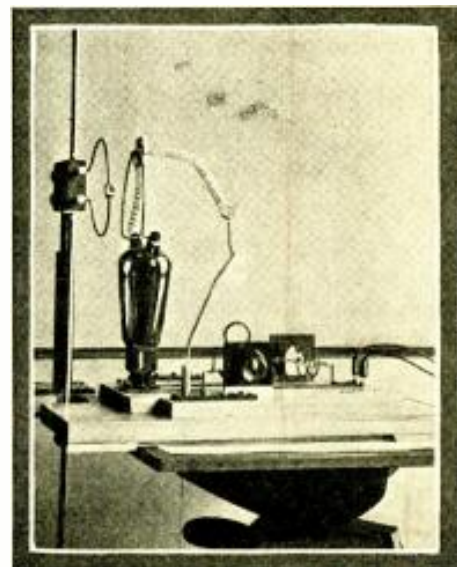

Fig. 11—3-meter transmitter with dipole antenna.

Portable S-W Receiver

By ROBERT "BOB" HERTZBERG

Cast one-piece aluminum case makes the new REL two-tube set both strong and light—A-1 features for vacation and auto use.



The "REL" short wave "portable" is just the thing for vacation days and week-end jaunts.

A PORTABLE short-wave receiver that is really compact and light enough to be carried around without breaking a wrist has been brought out by the Radio Engineering Laboratories, Inc., of Long Island City, N. Y. This little set, which has numer-

ous uses, is rather ingeniously constructed. The three features of lightness, strength and rigidity, which are essential to any "portable" receiver, are obtained by the use of an aluminum case cast in one piece without joints. It measures only 11 inches long, 7½ inches high, and 4¼ inches deep, and contains both "A" and "B" batteries in addition to a two-tube regenerative tuner and amplifier of simple but efficient design.



Right: The S-W portable is all enclosed in a cast aluminum case, which encloses and protects tubes, all batteries, and plug-in coil. Note phone jack below tuning dial.

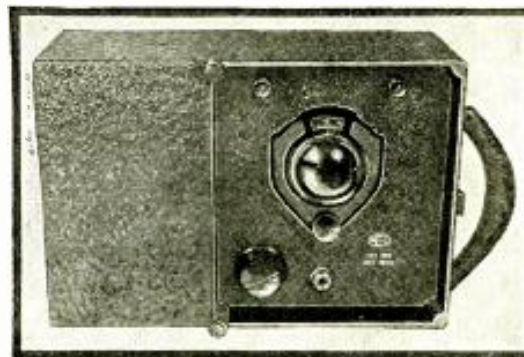

Left: Arrow indicates "REL" portable being used as a "monitor" in a "ham" station.

Fully loaded, the set weighs twelve pounds. Because of its flat construction and full-size handle, it is very comfortable to carry. It takes up about two-thirds of the room occupied by a portable typewriter, which it resembles in outward appearance. The case is finished in black crystalline lacquer, which is both clean and durable.

The controls are mounted on a recessed panel which is part of the casting. When the set is being carried this section is protected by an aluminum cover held in place by two non-removable locking nuts and a strong spring catch. The dial is on the tuning condenser. The knob in the lower left corner is the regeneration control. Under the dial is the earphone jack.

The back of the case is fitted with a full length cover, also held by thumb nuts and a spring catch. An accompanying illustration shows the set with the cover removed, to expose the parts inside. The midget tuning condenser and the two tube sockets are mounted on a bakelite shelf. Above the latter is a socket for the plug-in coils, and below are the audio transformer, the regeneration control and the other odd parts.

Two small 22½-volt "B" batteries and a 4½-volt "C" battery, used as an "A" battery, are wedged into the remaining space. They are prevented from moving by a wooden bar fastened to the inside of the cover. This simply presses against them when the cover is in position.

The two tubes are of the 230 type, and are connected in series directly across the filament battery. No rheostat is needed, as each tube takes two volts and the series arrangement makes the required voltage four volts. The battery is rated at 4½ volts, but this drops slightly in service. The current drain is only 60 milliamperes, which is an economical load on the "A" battery.

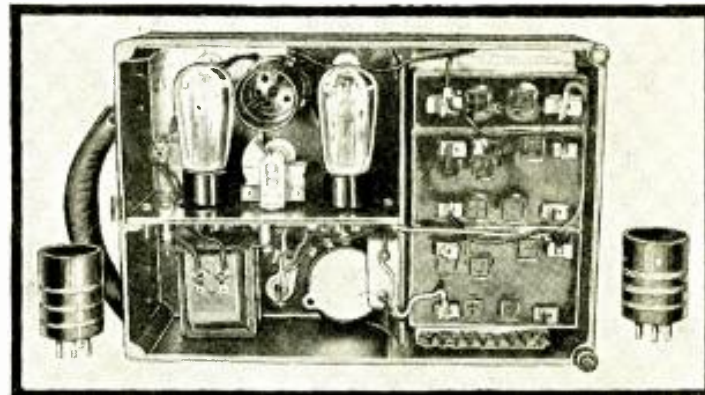

The complete circuit of the receiver is shown. This is a straightforward regenerative detector-one stage audio hook-up, which is known for its reliability and effectiveness. In the hands of an experienced operator the set will bring in most everything many larger sets will bring in, but not with as much volume. It is intended primarily for earphone reception, so tremendous amplification is neither necessary nor desirable. Incidentally, the earphone jack is of the filament control type; that is, it turns the tubes on when the phone plug is inserted, and shuts them off when it is removed. This is a very valuable feature in a portable set, as it prevents the owner from forgetting to turn the outfit off. The front cover cannot be put on unless the phone jack is out.

The regeneration control is a variable resistor in the detector plate lead. It has no appreciable effect on the tuning, and the dial may therefore be logged accurately providing the same aerial is used all the time. Different aerials will, of course, throw the tuning off slightly, as the tuning circuit is closely coupled to the antenna.

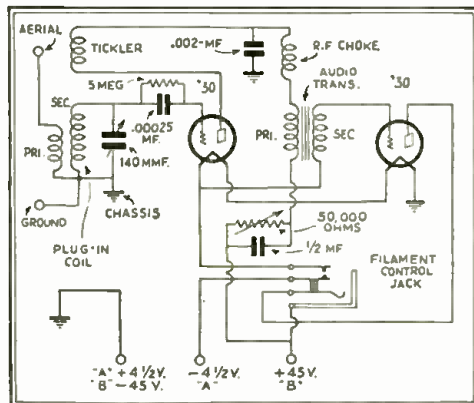

Diagram of "REL" short wave portable.

(Continued on page 418)

A CRACK GERMAN Short Wave STATION — D4AA1*

By DR. L. ROHDE

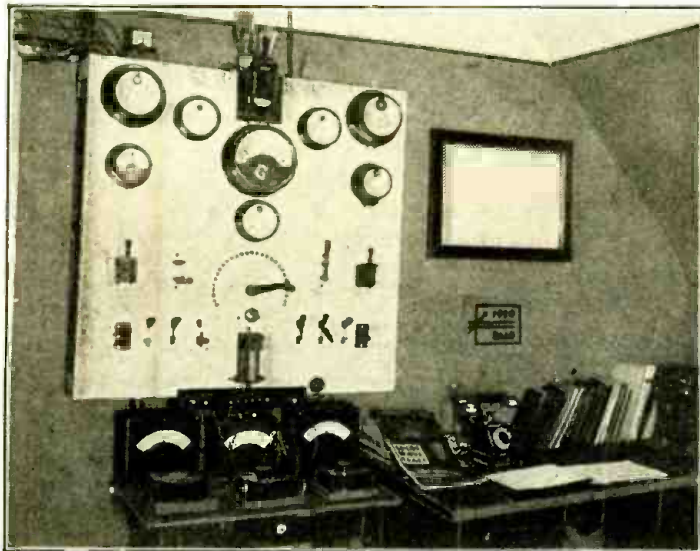

Fig. 3—The current distribution for the entire station D4AA1 is made from the switchboard shown in the photo at left. This station is well known to American radio amateurs, having been heard regularly on this side of the Atlantic.

ness of the wavemeter is .01 per cent. This exactness is attained by control with the harmonic vibrations of an auxiliary transmitter, which is stabilized by a quartz crystal. The short wave receiver has a wave range of 10 to 150 meters.

For the amateur a more interesting thing than the receivers is surely the transmitter, which is built according to

THE station D4AA1 was built for the investigation of the propagation of electric waves, particularly the short waves, from 10 to 100 meters in length.

The call signal D4AA1 is very well-known to the European amateurs, and even a great number of American amateur stations are in communication with this station. The most time has been given to operation on a 41.18 meter wave, radiated with an energy of about 50 watts.

The plan of the station is shown in Fig. 1. Most of the space is occupied by the receivers, which are arranged for a wide frequency range. The waves from 150 to 15,000 meters are received by the two loop antennas visible in the picture, which can be connected at will. The reception of very long waves is important because of the "time signals," which in Europe are mostly sent out on long waves. For the short waves a special receiver is available, operating on the superheterodyne principle and so arranged that the received wave can at the same time be measured very exactly. The exact-

* Technical-Physical Institute, Jena, Germany.

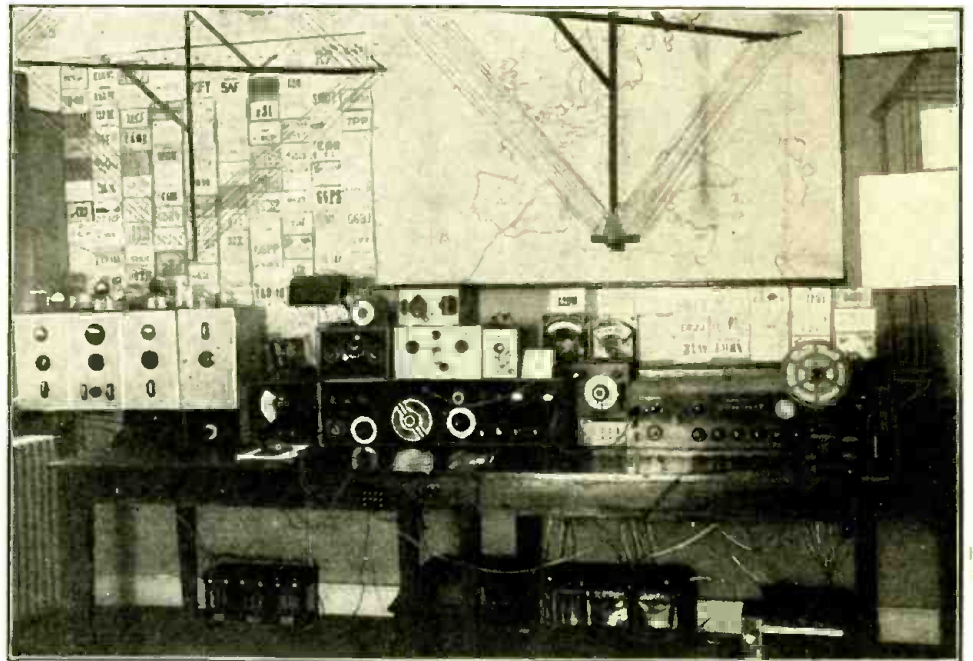
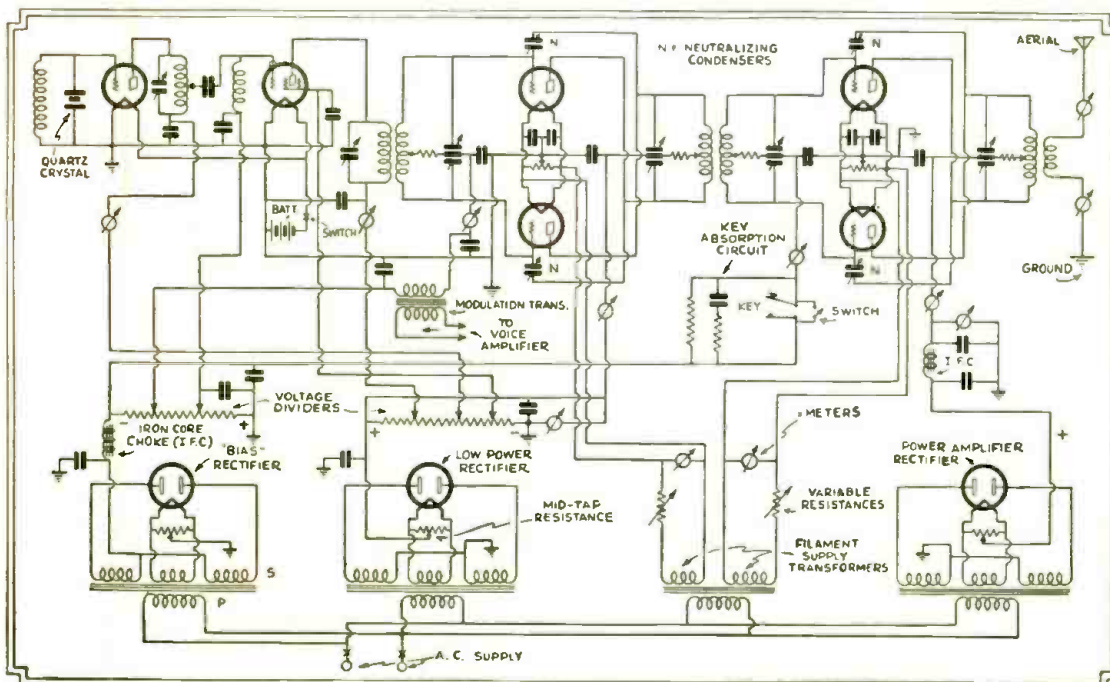

Fig. 1, Above—General view of "operating" table at short wave station D4AA1, located at Jena, Germany. "Long wave" as well as "short wave" receivers are provided. The short wave transmitter at left of photo, has 4 stages, designed for A.C. operation.

Fig. 2—Diagram at left shows hook-up of short wave transmitter used at D4AA1. The transmitter is crystal controlled and its call is quite familiar to American "Hams".



very modern viewpoint and whose hook-up is therefore given here. The transmitter appears in Fig. 1, at the left. Like all modern transmitters, it is built in compact form and is very small for an input of 150 watts. The transmitter has four stages and is built for all-electric operation. The rectifiers are "built-in". Fig. 2 shows the hook-up.

(Continued on page 422)

A 17 to 300 METER SHORT WAVE RECEIVER

By DALE TISDALE

WHILE this article is being written the author (in Iowa) is listening to a shortwave program from the shortwave station W8XAL Cincinnati, Ohio, on 6,060 kc. This station is coming in on the loudspeaker, with volume and quality that it may be heard in every room. This station's volume is comparable with a broadcast station fifty miles away, even though the rated power of the broadcast station is 50,000 watts.

The set consists of two main sections. The first section is a common stage of regenerative detection; the second section comprises two transformer-coupled stages of audio amplification. The audio amplifier uses two 4½ volt C batteries; this increased the volume somewhat. The first method used, was wired by hooking the filament on the transformer to the negative post of the tube. On

Here's just the set for the beginner—has 2-stage audio amplifier for loud speaker operation 'n everything. Coil winding data included, also all condenser values. Uses whatever tubes you have—'01A's for example.

Antenna

Now we come to the antenna which is a seven strand No. 22 copper wire, about seventy-five feet in length. The antenna is run toward the northeast, with the lead-in on the northern end. The height

point as near where the set goes out of oscillation as possible. Then a station is tuned in by regulating rheostat R1; by using this method any phone station may be tuned in without the usual station shift.

Use of Rheostats

In the audio stage the rheostats are used as follows: Rheostat R2 is used as a filament control; it will be found that once this is set, it will seldom need changing. The most useful of all the rheostats is R3. While serving as a volume and filament control it will also be found that by varying it slightly, the tone of an amateur phone may be controlled to such an extent that words which were not understandable are rendered intelligible.

The coil windings are as used in the present form; it will probably be necessary to experiment with the tickler windings of the set to obtain smooth regeneration, which is so necessary if the receiver is to function at its best.

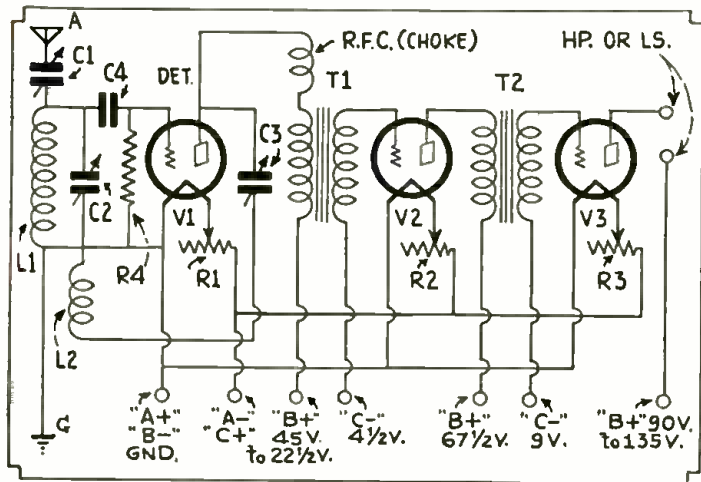

Here's Mr. Tisdale's "simplest" short wave receiver with audio amplifier. A 100,000 ohm resistance connected across the secondary of transformer T-1 will prevent howling, if it occurs. '01A tubes operated from 6 volt storage battery or good "A" eliminator fills the bill; '99's on 3 dry cells have been used by the editor.

Coil Data

Meters	Tickler	Secondary	Size Wire	Size Form
17-25	3	3	18 D.C.C.	tube base
22-35	3	5	same	"
32-50	3	6	same	"
48-90	8	18	same	"
80-130	10	22	26 D.C.C.	"
130-205	18	36	26 D.C.C.	"
200-300	20	40	24 D.C.C.	"

Coils from 250-1500 meters will have to be wound by experiment. I consider a ratio of 2:1 should be used (that is 2 turns on the secondary for every 1 turn on the tickler). The wire used is No. 42, D.C.C.

All of the apparatus except C2, C3, R1, R3, is mounted on the subpanel, and this makes a very nice panel arrangement. The main purpose in arranging the parts in this manner was to do away with hand capacity, which it does very successfully. To beginners let me warn never to use acid core solder, unless it is absolutely impossible to get any other kind. The first set I ever built was soldered with acid core solder, and I never heard such a roaring noise come from one radio. After testing the circuit for three days it was finally found that the acid has formed between two of the contact points on a tube socket.

The tubes which I use are those having the old brass type base. It will be found that these tubes will reach lower wavelengths than the new UX201-A in the bakelite base. The working voltages will be a good deal lower on the detector. The old tubes in my particular case seem to give much greater volume than the new; this may have been my imagination, but it will not hurt to try them. if the instructions which I have given are closely followed.

List of Parts

- C1—000015 m.f. variable midget condenser
- C2—00015 m.f. variable condenser
- C3—00025 m.f. variable condenser.
- C4—00025 m.f. fixed condenser
- R1, R2, R3—25-ohm variable resistors
- R4—4 meg. grid-leak
- T1, T2—3½:1 audio transformers
- L1, L2—See text
- V1, V2, V3—1X 201-A tubes
- RFC—Radio frequency choke coll.

short and extremely long waves the headphones are usually used, but at times the volume is great enough that the loudspeaker may be employed.

400 Stations Heard

It is not claimed by the writer that this radio set will bring in England as "regular as clock-work," but it will serve the persons who do not have the time or money to expend on a larger and better radio. This set will also be excellent for the beginner who wishes to learn the code. This set will bring in any station in the United States with reasonable power, as can be seen by the fact that over four hundred stations have been received.

The speaker is very good, and while some may think this a novel arrangement, I can assure them that it is not. To make the speaker, a Utah cone is taken, and the unit is removed from the speaker. Then the unit is fastened between the sound board and frame of a piano. Extreme care should be taken to see that the unit is fastened solidly as the speaker will rattle if not solid, and very little volume will be gained. The speaker thus fixed will give more volume, better quality and a purer tone than the average magnetic loudspeaker.

is thirty feet on the leadin end, and the southern end is thirty-five feet. The leadin to the point where the wire enters the house is No. 14 rubber covered wire. A leadin strip is used to bring the leadin wire into the house. The wire from the antenna post of the radio is No. 18 DCC copper wire. This wire is wrapped with tinfoil, and the tinfoil grounded. This was found to eliminate deadspots, which often makes portions of the coils untunable. The working voltages on the detector will also be greatly reduced. The voltages which are used at present with the set are 22½ volts on all coils from 35-150 meters, and on all other coils 45 volts is used.

The panel of the set is made of prest wood, which may be purchased at almost any lumber yard, and when varnished takes on a very pleasing finish. There is a piece of tinfoil glued to the back of the panel to serve as a shield. The parts which are insulated from the panel are, C3, R1, R2, R3; the condenser C1, is grounded to the tinfoil shield.

It was found after much experiment that it is best to use three rheostats. The rheostat R1 is used as a filament control to the detector tube. It is also used as a regeneration control; this is done by first tuning condenser C3 to a

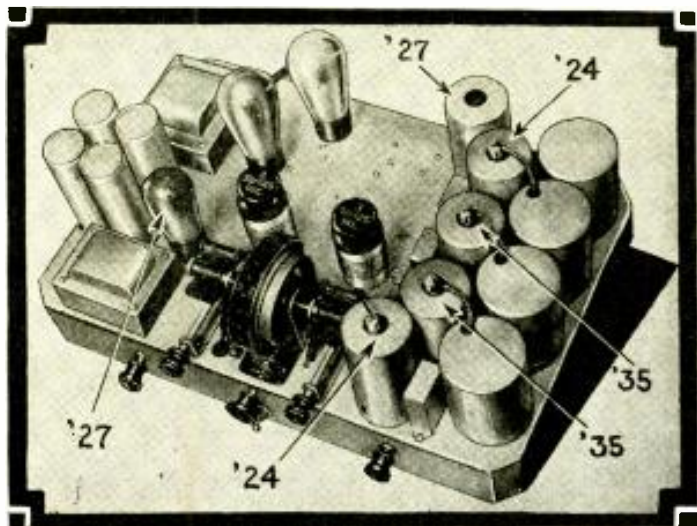

The new "Comet" all-wave superheterodyne, engineered by Hammarlund. Eight tubes, with wave bands changed by plug-in coils.

The *NEW* HAMMARLUND *ALL-WAVE* "COMET" RECEIVER

By LEWIS W. MARTIN*

THE thoroughly captivating feature of radio has always been DX (distant station reception). With the advent of short waves and their innate globe circling characteristics, the fascination has become more stirring than ever. And now, especially so, with the recent development of an ultra-sensitive receiver.

The newly produced device, providing this world-wide station coverage is the new Hammarlund all-wave super-heterodyne, the "Comet". The receiver not only fills the precision requirements for real short wave work, but broadcast work as well.

The marked engineering advancements that have been incorporated in this new receiver, which, by the way, is a custom-built project, a Hammarlund characteristic, are clearly evident from the accompanying text.

An eight tube model, the "Comet" uses: 2 '27's as oscillators; 2 '24's as detectors; 2 '35's (variable Mu's) as intermediate frequency amplifiers; a '47 (Pentode) in a resistance coupled audio amplifier, and an '80 as a rectifier.

The intermediate frequency stage uses a cleverly engineered band-pass tuning system, to afford extreme sensitivity and selectivity with faithful reproduction throughout the entire audible range.

Another unusually interesting feature is the second oscillator, which serves a dual purpose. By putting this tube into play, by operating a switch on the instrument panel, distant stations on both broadcast and short waves can be located with utmost simplicity and, also, it enables the reception of CW signals (code) with ease.

Another feature of the receiver is the *variable tone control*; this device also enables the elimination of noise.

To facilitate precision tuning, the major tuning control is supplemented by two fool-proof mechanical verniers, one for each condenser, located on each side of the major control knob. Incidentally, the projection scale method, which affords magnification of the scale indications, is used. This, of course, provides easy selection of stations.

For maximum efficiency throughout the entire wide range of frequencies

Eight tubes, working in a highly efficient super-het circuit of latest design, with a custom-built chassis, plus "plug-in" coils of new low-loss design, provide coast-to-coast reception on A.C. Wavelength Range 14 to 550 meters.

which this receiver covers, special Isolantite form plug-in coils are used. These provide complete coverage of all the bands, including broadcast. There are five sets of coils, two coils to a set, having the following ranges: 14-30, 28-60, 56-125, 120-300, and 240-550 meters.

A new Hammarlund dynamic speaker has also been designed for use in this all-wave receiver. It derives all the necessary power for energizing its field coil from the set.

A special Oriental Burl Walnut cabinet is also provided for the receiver. A feature of this cabinet is a lid, which enables easy installation of the plug-in coils. Incidentally, pockets are provided for the housing of each coil, thus further simplifying coil installation.

The chassis is only 19" long and 12 1/2" deep. As is evident, the set is also very compact. The receiver has been designed for operation from 110 volt, 50-60 cycles, A.C. lighting circuits.

Discussion of Circuit

The super-heterodyne has often been referred to as the "king" of radio receivers, chiefly because its circuit simplifies the problem of obtaining *uniform* radio frequency amplification of almost any desired amount and at the same time a high order of selectivity which is also substantially uniform over a wide band of signal frequencies.

With the superheterodyne principle this difficulty disappears. By means of the local heterodyne oscillator, the 1,000 K.C. signal (which we shall assume to be the one desired) is changed to 465 K.C. At the same time, the undesired 990 K.C. signal is changed to 455 K.C., and both signals are impressed on the intermediate amplifier. The intermediate amplifier then has the task of amplifying the 465 K.C. signal (for which it is tuned) and reducing (or rejecting altogether) the 455 K.C. interference. This is comparatively easy as the percentage

difference here is 10/465 or over 2%. The effective selectivity in this case has been more than doubled. This effect increases rapidly with increasing signal frequencies. In the case of the 15,000 K.C. (20 meter) and the 14,990 K.C. signals the same process takes place. The 15,000 K.C. signal is changed to 465 K.C. and the 14,990 K.C. interference to 455 K.C. This also results in a percentage difference of more than 2% (as was the case with the 1,000 K.C. and 990 K.C. signals) which corresponds to a gain in selectivity of over 30 times as the original percentage difference between the two signals was only 1/15 of 1%.

An important point must be considered here, however. This gain in selectivity as outlined above is only realized *if* the tuned circuits, constituting the intermediate amplifier, have low-loss characteristics comparable to the good tuning circuits used at broadcast signal frequencies in high-grade receivers. If the intermediate coils are, for example, only

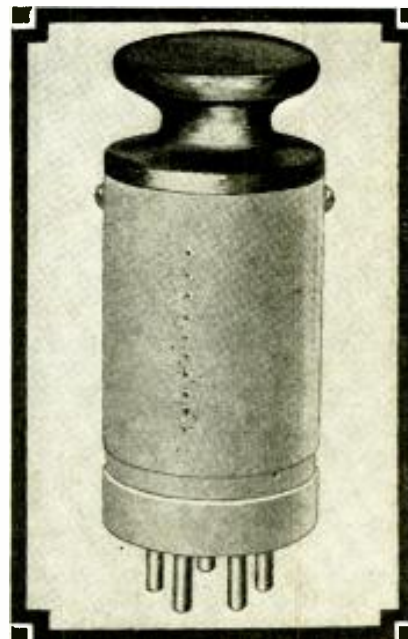

Maximum efficiency is attained in the new Hammarlund all-wave set by using "Isolantite" coil forms.

* Hammarlund-Roberts.

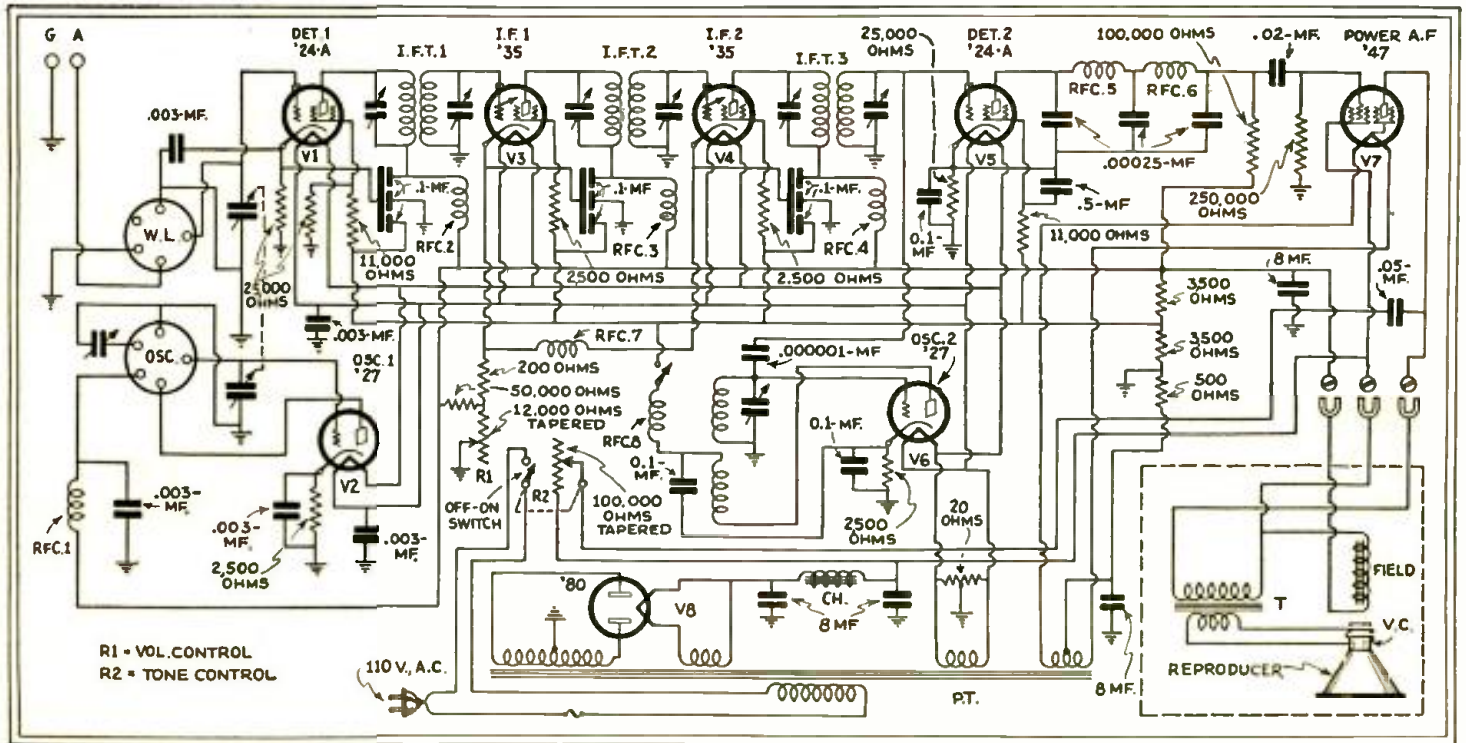

The interesting all-wave superheterodyne circuit developed by Hammarlund engineers. The wave bands from 14 to 550 meters are provided for by changing two plug-in coils at sockets "WL" and "OSC," insuring maximum freedom from dead-end losses. All circuits are fully by-passed and with the carefully designed I.F. stages, and A.F. amplifier, a signal of great volume and high quality is assured on all wave lengths.

one-fourth as efficient (for reasons of economy) the gain in selectivity due to the shifting of the frequency (as outlined above) is proportionately reduced. Thus in the case of the 15,000 K.C. signal the gain in selectivity would be only 7½ times and in the case of the 1,000 K.C. signal there would result an actual loss of 50% in selectivity instead of a gain of 2 times.

The intermediate coils used in the "Comet" are wound with special "Litz" wire, resulting in a power factor of .01 (Q of 100), and no effort has been spared in their design and construction to make them highly efficient. Six of these coils are used, two in each transformer, in the tuned plate-tuned grid hook-up. This provides six sharply tuned low-loss circuits in the intermediate amplifier. While this arrangement affords extreme selectivity, the double-tuned critically-coupled circuits result in a steep-sided response curve with a rounded top, thus minimizing the type of radio frequency distortion known as side-band cutting. All the above factors together account for the remarkable selectivity of the "Comet" at both broadcast and short waves.

Although it is obvious that a lower intermediate frequency would afford even greater selectivity, by reason of a further increase in the percentage frequency difference, there is another consideration which makes a high intermediate frequency desirable. All superheterodyne receivers are subject to "image" interference, which stated briefly, means an undesired signal whose frequency difference from the desired signal is exactly equal to twice the intermediate frequency used in the receiver. It naturally follows that a high intermediate frequency lessens interference from this source. A maximum spread between a desired signal and its image interference is especially important in short wave reception.

On the other hand modern design necessitates the use of an intermediate frequency materially lower than that of any of the signals to be received. For these reasons 465 K.C. was chosen as the intermediate frequency for the "Comet".

New Isolantite Coils

The interchangeable plug-in coils are wound on treated Isolantite forms. This material has very low dielectric losses which are very important especially at high frequencies. In addition its extremely stable physical characteristics insure constant inductance with consequent reliability of dial calibration, which is very important at short waves where the tuning is necessarily quite critical. The wavelength coil for the lower broadcast frequencies has a very high inductance value, and this is secured by a

"two bank" winding of the same "Litz" wire used in the intermediate coils. This results in a very low-loss winding with attendant high gain and selectivity.

The tuning ranges of each of the five sets of coils is given in one of the diagrams. Ample overlap is provided, insuring complete coverage of the entire range of 14 to over 550 meters.

Novel Filter System

A '24-A type screen grid tube is used as a first detector or "mixing" tube. Its high detector sensitivity as well as its high output impedance make it ideal for this purpose, as it works into the high impedance tuned plate coil of the first intermediate transformer. A further advantage of this tube is its high input (grid) impedance, with correspondingly low effective input (grid) capacity, which together reduce the damping on the tuned input circuit (the W.L. coil and its associated tuning capacity) and permit a larger wavelength range with a given coil and tuning condenser.

The second detector is also a '24-A type screen grid tube working as a plate-circuit rectifier. Its control grid is automatically biased by a cathode resistor, resulting in substantially linear power detection. In addition to audio frequencies, there is also a large component of intermediate frequency present in its plate circuit. This I.F. component is filtered out by means of a two-stage, low-pass filter, consisting of two 85 millihenry R. F. chokes and three .00025-mf. by-pass condensers. These two filter stages are separately shielded from each other. This elaborate filtering is extremely important, as otherwise the I.F. component would also be amplified by the output pentode, and would appear in its output circuit, causing overall feedback to the input of the receiver, resulting in great instability

(Continued on page 430)

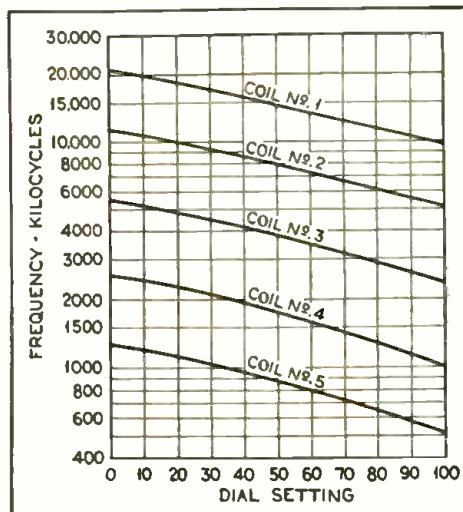

The curves above show how well the wave bands are covered by the Hammarlund plug-in coils.



A rear view of the 3-tube short wave receiver appears below. This receiver employs a '37 detector, a '36 first audio and a '38 pentode in the second audio or output stage. A very neat and well-designed job.

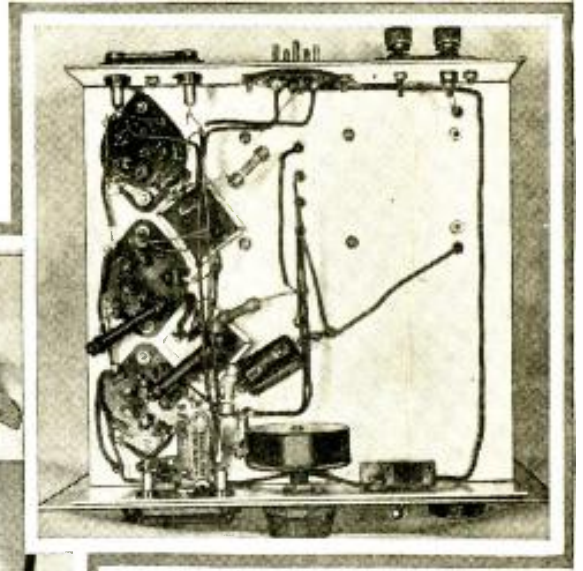

Bottom view of the receiver appears above; it will be seen that a minimum of cross-wiring results with the apparatus laid out according to the writer's design. The "plug-in" coils are fitted into the elevated socket, marked by the arrow in the center photo. The chassis and shield are of aluminum.

Above—The operation of removing one of the "plug-in" coils is shown clearly above. Many experts prefer the "plug-in" type of short wave receiver, and so here is a set that will appeal to them. After the coil has been put in place a metal cap covers the opening and thus completes the "shielding".



The DENTON STAND-BY

WHILE a good big man bests a good little man, it is amazing and creates a feeling of satisfaction indeed when a good little set out-performs the bigger jobs.

Aided by the eccentricities and cussedness of normal short-wave operation, one has nearly as many chances to reach a great distance with a *small* receiver as with a *large* one.

The necessity of having some check on general short-wave reception conditions existing from day to day, without going to great expense, led to the receiver herein described and called by the author the "Standby".

It will be noted that the set is battery-operated, employing the new 6-volt tubes and including the pentode. A storage battery or a good "A" eliminator can be used if desired.

Plug-in Coils Used

Starting at the antenna, we find the small coupling capacity which is adjusted

3 TUBE S-W Receiver

Described in Detail

By CLIFFORD E. DENTON

Who Designed It

Low first cost, coupled with good design and "loud speaker" operation are particularly desirable attributes in any short wave receiver today. All of these features are found in the 3-tube short wave receiver here described by Mr. Denton, which will appeal to every reader, we are sure. All coil and condenser data are given for its construction.

carefully when the set is placed in operation, and seldom needs further attention. The large spaced winding of the plug-in coil is tuned by a .0005-mf. condenser which has been cut down and double spaced, with 7 plates on the rotor and 8 plates on the stator. With these changes the maximum capacity then becomes exactly .00015-mf. Shunted across this master tuning condenser is a small 5-plate midget condenser, with three of the plates removed. This condenser in its final form has but one stator and one rotor. Builders will find it necessary to widen the distance between the two plates with spacing washers; so that a full 180-degree turn will separate two channels; this will be found very convenient when tuning to two code stations on adjacent channels as well as phone reception.

Grid-Leak Detector Employed

Detection is accomplished by the conventional leaky-grid method; and the only

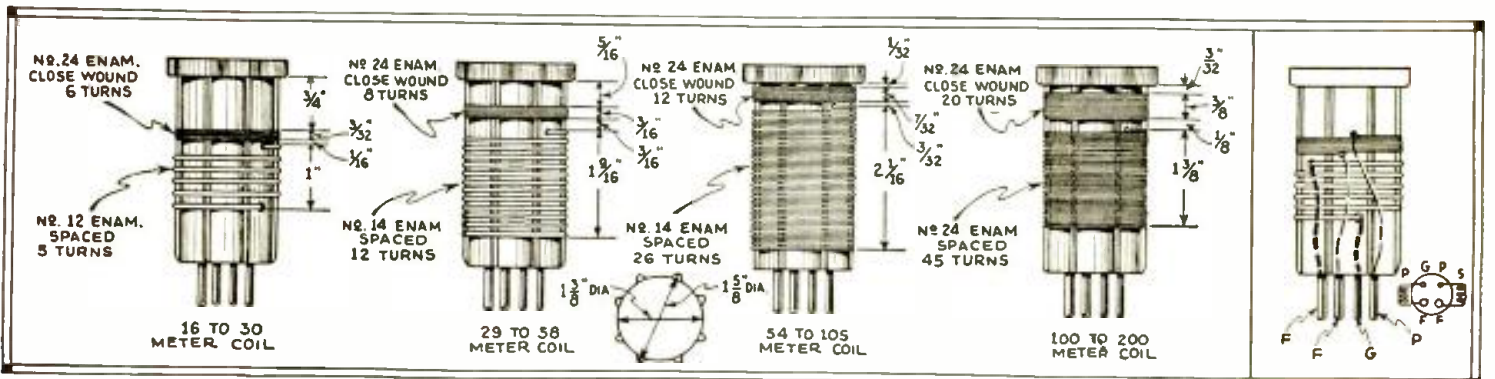

Winding data are given above for the four "plug-in" coils, which cover all the short wave bands from 16 to 200 meters.

novelty in conjunction with this circuit is the means of critically controlling the steady-state (no signal potential on the grid) potential of the grid. This is done by variation of the cathode potential to the common ground and is extremely valuable in controlling the action of the tube under regenerating and oscillating conditions.

Effective Regeneration Control

The regenerative control is a potentiometer connected across the plate coil and offers smooth operation with the minimum "detuning" of the resonant circuit which is so desirable. The use of the 10,000-ohm resistor in place of the detector plate choke, in conjunction with the resistance-capacity-coupled stage, tends to eliminate "fringe howl" and makes positive the action of the regeneration control.

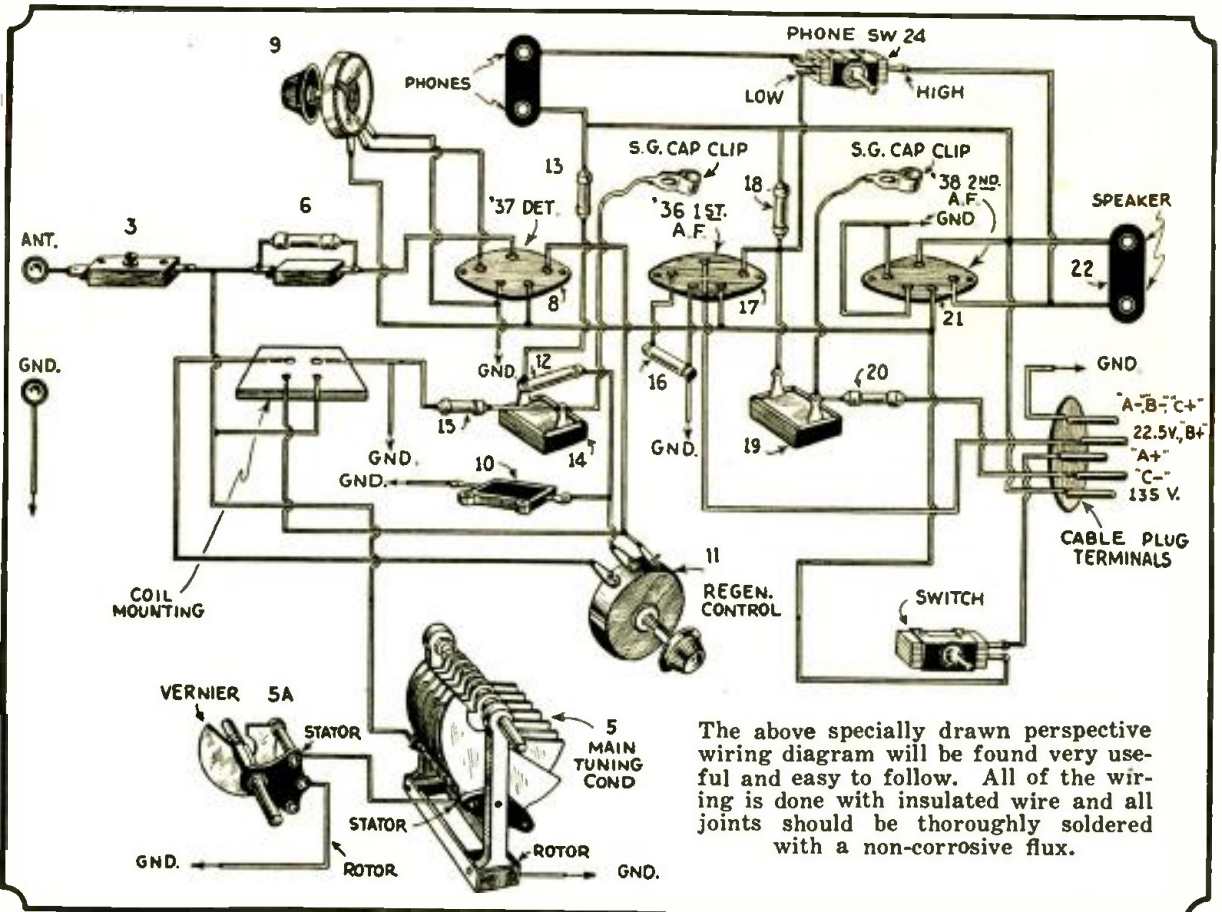

The above specially drawn perspective wiring diagram will be found very useful and easy to follow. All of the wiring is done with insulated wire and all joints should be thoroughly soldered with a non-corrosive flux.

Two Audio Stages

The first stage of audio uses a ER236 type tube, the output of which is resistance-capacitively coupled to the ER238 (or R.C.A., same numbers), output pentode. (If the constructor cannot obtain the pentode, the recommendation is to use a general-purpose ER237 instead.) It will be noted that the loud-speaker is always placed in the plate circuit; but that the phones can be transferred from the first to the second audio stage by use of the single-pole, double-throw switch. When the phones are connected to the output of the screen-grid tube, the total available energy fed to the speaker is reduced; and thus, when listening with the phones, the speaker output is diminished to such a point that it would not be objectionable, even late at night.

Front Panel Arrangement

Looking at the photograph showing the front of the receiver it will be noted that the master tuning dial is in the center. The regeneration control is located directly under the tuning dial. The control on the left seen facing the panel is the "band-spread" condenser, while the control on the right is the sensitivity control. This is the potentiometer connected across the filament with the moving arm connected to the cathode of the ER237 detector.

The switch on the lower left is the filament on-off switch; while on the right are the earphone jack and the high-low power phone switch.

On the chassis we have the three sockets, tuning condenser, bakelite coil support, antenna condenser and the leads to the control grids of the tubes. All wiring

is so done as to keep the top of the chassis as free from any traces of wires as possible.

It will be noted that the only inductances used in the receiver are the grid and regeneration coils used in the inductance socket. The balance of the receiver is made up of resistance and capacity elements.

Construction

The complete mechanical details of the aluminum case, front panel and chassis will be found in the drawings which accompany this article. The completely drilled and assembled case can be obtained all made up if so desired.

Mount the filament switch, phone twin-jack, phone power switch and the regeneration control on the chassis and front panel. Be sure that the regeneration control is insulated! This operation will securely fasten the front panel to the chassis. Mount the tuning condenser and dial on the front panel. First fasten the small retaining screw furnished with the dial; since it is difficult to mount the dial properly after the tuning condenser is mounted. The "band-spread" condenser is mounted on the left hand side of the front panel. The 200-ohm potentiometer is mounted and insulated from the front panel.

Mount the antenna, ground, and loud-speaker connectors on the back of the chassis. The special male-type wafer socket is used so that the contacts on the female member soldered to the battery cable will not "short-circuit" the batteries if the cable is dropped on a metal-topped table or bench.

The three sockets and the antenna coupling condenser can be mounted as shown in the photographs.

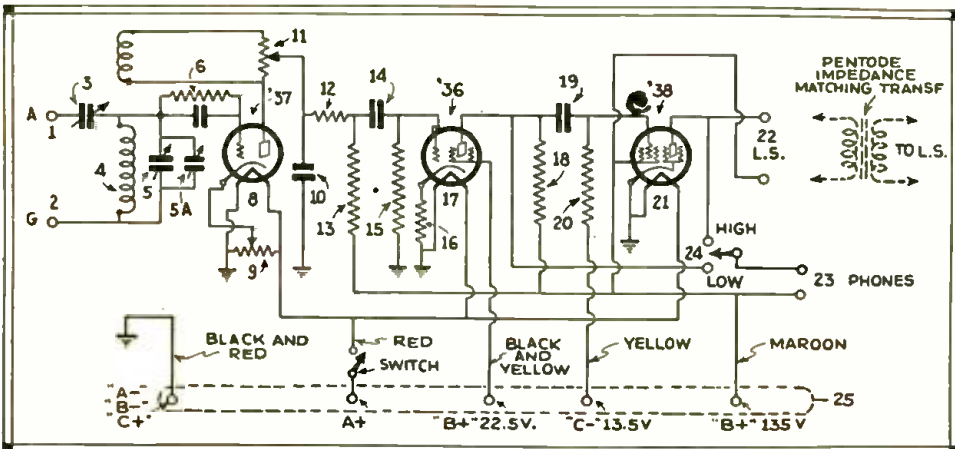

Schematic circuit of the Denton "Stand-By" 3-tube receiver, which operates a "loud speaker".

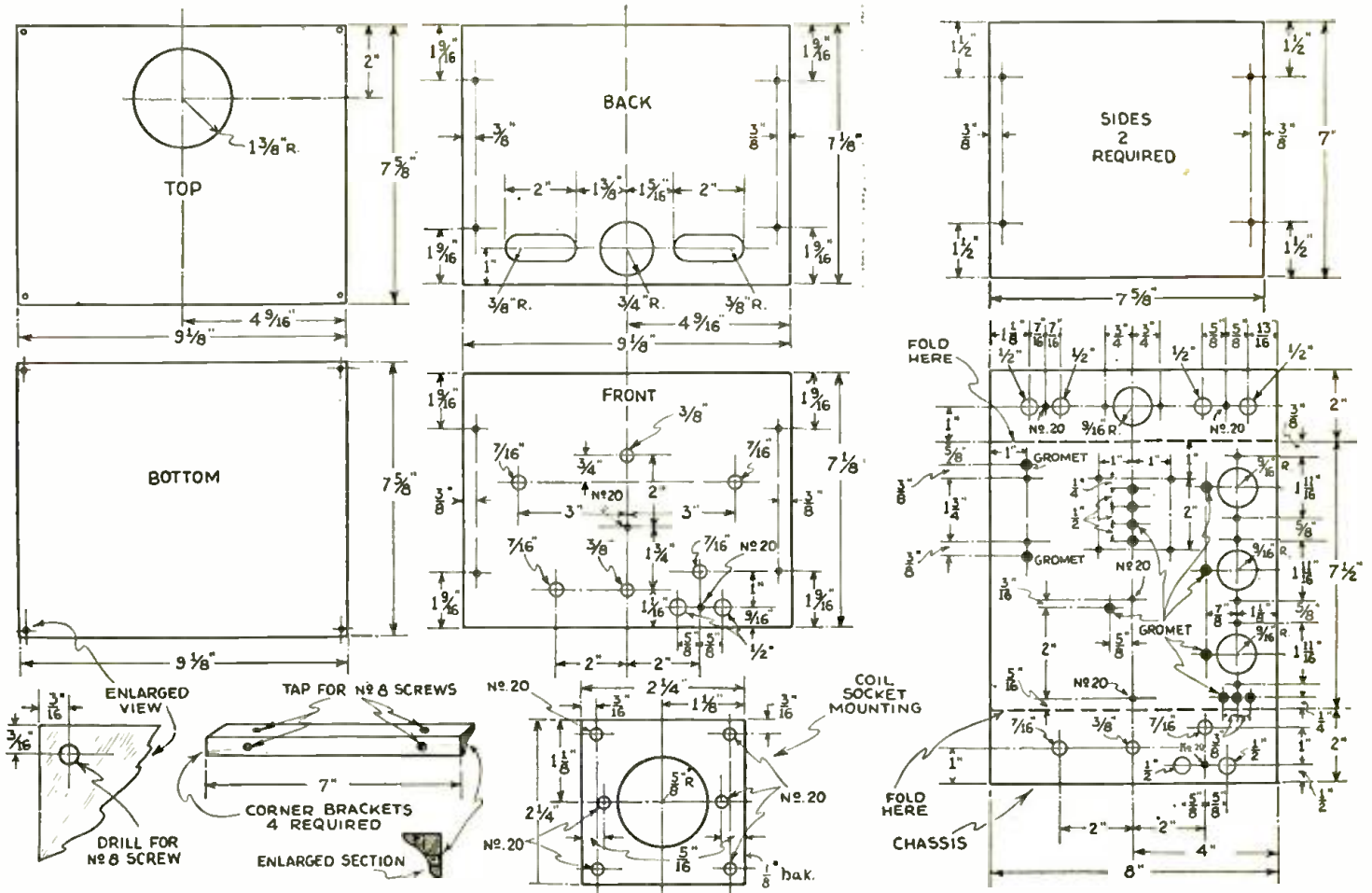

Drilling and layout dimensions are fully given in the above drawings so that the S-W constructor can build his sub-panel and shield compartment for the Denton "Stand-By" receiver. Aluminum, brass or zinc sheet stock about 1/16 inch thick can be used.

Since less than 15 feet of wire is used it can be seen that the time necessary to make a neat job is at a minimum. Sufficient to say, at this point, first run and solder securely the wires which lie closest to the chassis; such as filament, plate and grid lines, leaving the "B" supply lines one inch up from the chassis to minimize any coupling which may exist. With a careful examination of the circuit and pictures, there should be no difficulty in making a quick and neat job.

This receiver has proven as useful as its name implies—"Standby". Whenever the author wanted an idea of the conditions existing over the various S.W. bands, the old "Standby" was switched on; and, due to familiarity with the set and local receiving conditions, a handy check was soon to be obtained. This is often very useful when testing other S.W. receivers which may be under design construction or in for repair.

Parts List

- 1 Set of Octo Coils (4).
- 1 XL Variodens (3).
- 1 Eby '37 Type Wafer Socket (8).
- 1 Eby '36 Type Wafer Socket (17).
- 1 Eby '38 Type Wafer Socket (21).
- 1 Eby Antenna, Ground B, Postrip (1, 2).
- 1 Eby Dial Phone Tip Connector (23).
- 1 Eby L.S. Tip Connector (22).
- 1 G.E. Power Toggle Switch (18).
- 1 S.P.P.T.—Toggle Switch (24).
- 1 Frost 50,000-ohm Potentiometer (1) with insul. washers.
- 1 Carter 200-ohm Potentiometer (9) with insul. washers.

- 1 Pilot Midget Condenser (5A) (J5).
- 1 Pilot ART Dial.
- 2 International Durham 1/2-watt, 0.25-meg. Resistors (18, 20).
- 1 International Durham 1/2-watt, 0.5-meg. Resistors (15).
- 1 International Durham 1/2-watt, 0.1-meg. Resistor (13).
- 1 1-watt, 10,000-ohm Resistor (12).
- 1 1-watt, 500-ohm Resistor (16).
- 2 Dubilier .01-mf. Mica Condensers (14, 19).
- 1 Eby 5-contact Wafer Male Connector Unit (25) with female receptacle and wire cable.
- 1 .001-mf. Mica Aerovox Condenser (10).
- 1 .000125-mf. Mica Illini Grid Condenser (6).
- 1 5-meg. International Durham Grid Leak (7).
- 1 National .0005-mf. Condenser cut down to .00015-mf. (5).
- 1 "Blan" Aluminum Box and Chassis cut and drilled to specifications, with special coil cover "cap" and bakelite coil mounting assembly.
- 12 Insulated Eyelets.
- 2 Grid Grip Screen-grid Clips.
- 15 feet Rubber-Covered (push-back) Wire, Nuts, Bolts, Lockwashers, Soldering Lugs, etc.

The World Radio Time Indicator

The earth is divided into 24 time zones of 15 degrees each, or approximately 1,000 miles in width at the equator. Greenwich (London, Eng.) where time commences is located in the center of the first or zero zone and the time in all 12

zones lying eastward from Greenwich to the International Date Line or the 180th Meridian is always fast or ahead of Greenwich time and all 12 zones lying westward from Greenwich to the International Date Line are always slow or behind Greenwich Time.

Reading the Indicator from left to right from Suva at the International Date Line up to midnight, the time is "today" and continuing on left to right from midnight down to Suva the time is "tomorrow" or a day ahead of all points or zones on the other side of the International date line and midnight.—Illustration courtesy The Bagshaw Radio Instrument Company.

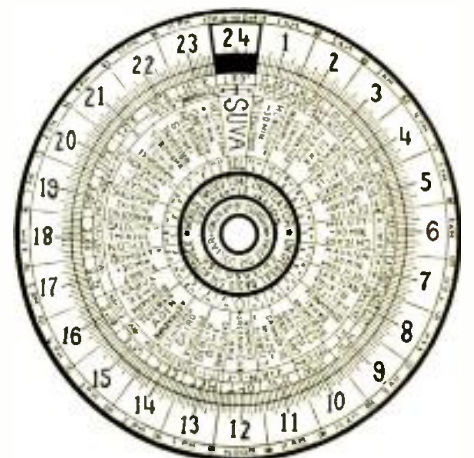

New world radio time indicator.

SOLVING the PRESENT BROADCAST PROBLEM

By THOMAS A. MARSHALL
Eminent Short Wave Expert

In the course of which Mr. Marshall gives us some very valuable information on short wave converters suitable for waves as low as 5 meters.

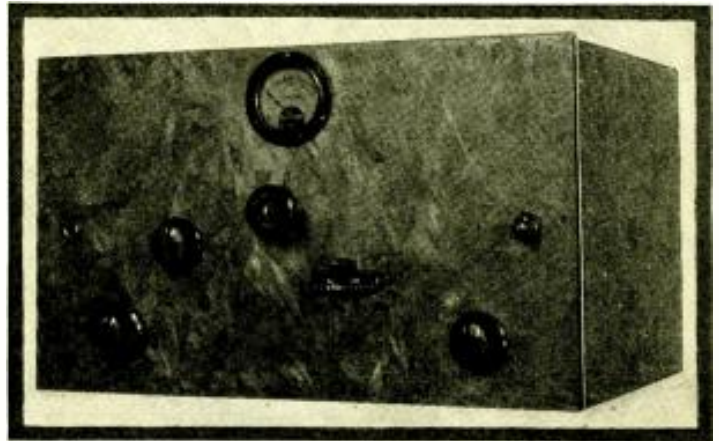

Fig. 1—Front view of the short wave receiver designed and built by Mr. Marshall.



THE AUTHOR

Mr. Thomas A. Marshall, who wrote the accompanying article, is one of the foremost short wave experts in America. Many of his articles have appeared in the leading radio publications, especially those dealing with short waves. Articles from his pen have appeared before in SHORT WAVE CRAFT. Undoubtedly our readers will be glad to read Mr. Marshall's latest article.

THE arguments here presented are the results of a first hand opportunity to conduct tests within the ultra short wave bands. After you have read this article you may be compelled to revise the generally accepted idea about utilization of the ultra short waves, because the writer has devised a new method for local broadcast as well as television, using these frequencies.

After many years of development of radio, broadcasting finally started when the Westinghouse Company applied to the Secretary of Commerce for a license for station KDKA. In granting this station a license, the Secretary of Commerce determined that a wave length of 360 meters would be a safe place for broadcasting programs because it was far enough away from frequencies assigned to ships and shore stations.

Shortly after this time, other broadcast stations were licensed to operate on this wave length, while others were given 400 meters. The interference problem started,

and has been a bone of contention ever since. The existing law in 1927 expressly provides that no one shall be granted a license to operate a radio broadcast station without first proving that his business is in accord with the "public interest, convenience, and necessity." The reason for these restrictions was due to the fact that there is not room for all the present 700 stations to operate within the band from 550 to 1,500 kilocycles. In fact, half this number of stations would give better results. The Federal Radio Commission realizes this very condition, and is on the look out for violators of obscene language, libel, slander, and of wave offenders. Recently, a station was put off the air for being off wave length, while another station was refused renewal of license because of obscene language. To the writer, it is a cry is for more stations, bigger and better stations. Yet the Federal Radio Commission cannot satisfactorily iron out all the difficulties confronting it at the present time. Conditions have improved in many ways but not to a perfect degree. It is simply a problem belonging to the impossible as long as there are so many stations which have integral and fractional relationship to one another. As long as this condition exists, we will continue to receive hum on certain stations, whistles on others, a roar on some of the stations on the lower side of the band, while some of the stations on the upper side will have fuzzy music.

Television—Its Frequency Demands

In our minds, radio broadcast is only one element. There is television just around the corner. To tell the truth, I believe that television will be much bigger than radio ever was. Naturally, every one will want to have a television set. The public will pay more than \$50,000,000 during the first year for seats at the big show, and will want the best set produced as well as the best entertainment. Furthermore, what was an excellent set two years back would be antiquated today. Thus, we see that the radio apparatus manufacturers will pay the whole bill for the best of programs.

How are we to bring about this band? The answer appears to be given by offering the *ultra short wavelengths* for this work. The shortest assigned wavelength assigned to a commercial concern is 14.15 meters. Below this wavelength there are hundreds of channels which could be utilized for broadcasting programs, tele-

vision, aeroplane beacons, etc. In fact, between 6.6 meters and 14.15 meters (21,200 to 45,000 kcs.) there are 2,380 channels, having a separation of 10 kilocycles. These channels will be suitable and adaptable for local broadcasting. In fact, every large town can have more broadcast stations than there are now in the United States.

This is made possible due to the limited range of each station operating on extremely short wavelengths. These stations would not interfere with one another at great distance, due to the fact that the *sky-wave component* does not return to the earth. However, the *ground wave component* clings to the earth and is gradually absorbed as the distance is increased. The distance for the ground wave component decreases as the wave length is decreased. Thus, 14.15 meters has a limited range of approximately 160 miles. As shown in Fig. 2, 6.6 meters would serve satisfactorily for short limited range, while for greater ranges, 14 meters could be employed. Thus, for New York, 11 to 14 meters would probably cover the whole city.

It is estimated that about 20% of the broadcasting time is taken up with chain programs which are of great interest. This method could continue, as it is of prime importance to all concerned, and can reach the rural districts. There are 95 channels within the present broadcast band. These channels can be employed for chain hook-ups by having at least one high power station in each state. Chain broadcasting may also be sent over the *ultra short wave stations* for cities and certain districts which would insure re-

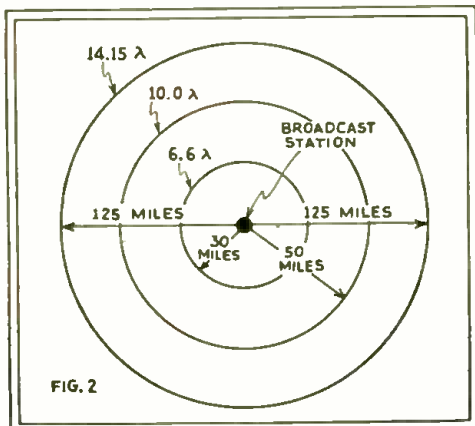

Fig. 2—Shows receiving limits of ultra short wave lengths.

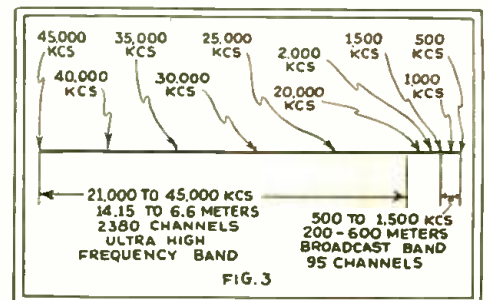

Fig. 3—The frequency line up of the present broadcast band and the recommended channels. Note the small percentage of the frequency spectrum utilized by the present broadcast stations, in comparison with the short wave band as mentioned in this article.

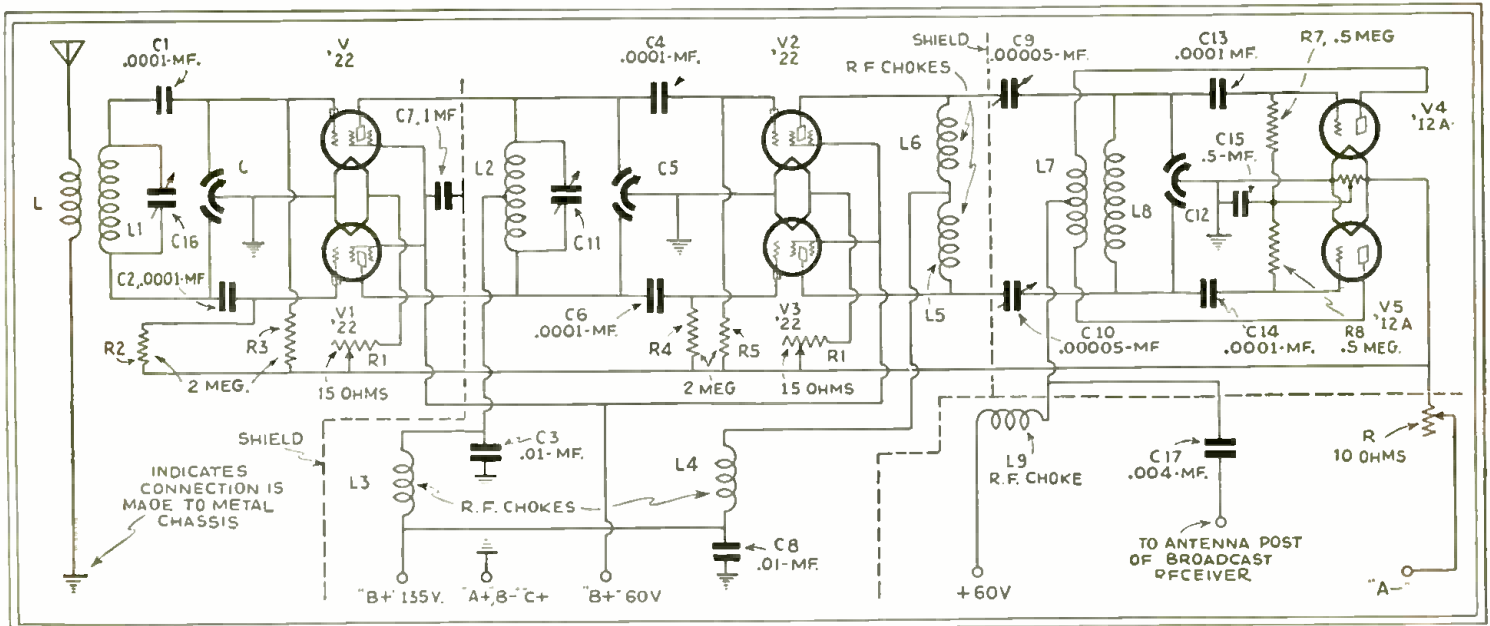

Fig. 5—Circuit diagram of short wave converter designed by Mr. Marshall and which employs push-pull in the radio frequency and detector stages.

ception everywhere. Local or "spot" advertising will always be demanded as it is valuable and necessary for many commodities which present a purely local advertising problem. Local events, elections, church services, and news require local broadcasting facilities. In these local broadcasts, local people will be just as much interested as they are at other times in reception of national and international topics. Thus for the demands of local broadcasters, the *ultra short wave* field will serve to an advantage, while for the ones who want to receive distant stations, the present band can be utilized as it will be free from so much interference.

Results of Tests on 6 and 7 Meter Signals

During the month of December, the writer observed signals in the vicinity of Los Angeles, Calif., from a 500 watt transmitter located at San Pedro, Calif., and tuned to 7.5 meters. This transmitter gave excellent results throughout the streets of Long Beach, Calif., Torrence,

Inglewood, Lynwood, and through the outskirts of Los Angeles. The signals from this transmitter were considered to be good, due to reception taking place at 10,000 to 50,000 microvolts per meter.

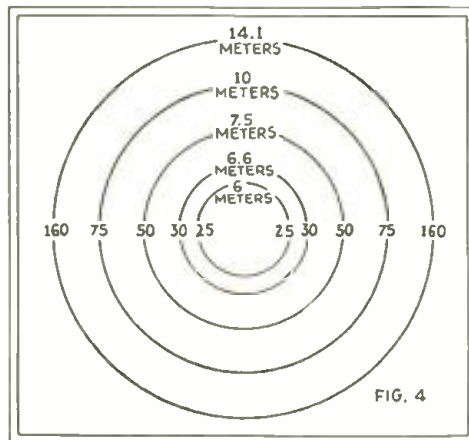

Fig. 4—Another chart showing range of ultra-short wave lengths.

During another test held at Santa Anna, results on 6.6 meters ran from fair to poor, depending on the location of the antenna. Of course, with transmitters placed at a high elevation, and receiving antennas on top of homes, much better results would be made possible. High-powered transmitters would also increase the distance as well as the signal at a given distance. The chart in Fig. 4 shows reception of various frequencies at various distances from the transmitter located at San Pedro, Calif. From the results accomplished during these tests, it is apparent that extremely short wave lengths do not have undesirable ranges; they guarantee good reception without fading and weakness which are inherent to the longer wave lengths. These ultra short waves may readily be modulated with a very wide width for television transmission. Thus, solving the demand for this new art.

The diagram in Fig. 5 represents a *short wave converter* which is suitable for reception of extremely short waves. It is used in conjunction with a regular broadcast receiver, and converts the extremely short waves to the present broadcast range.
(Continued on page 424)

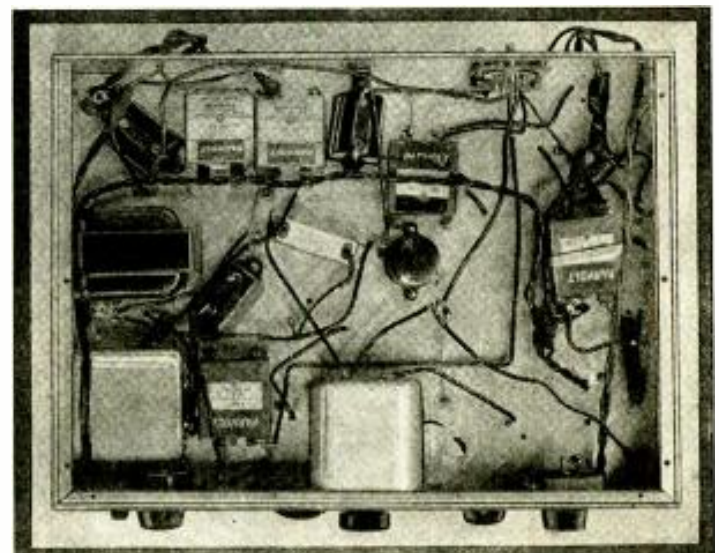
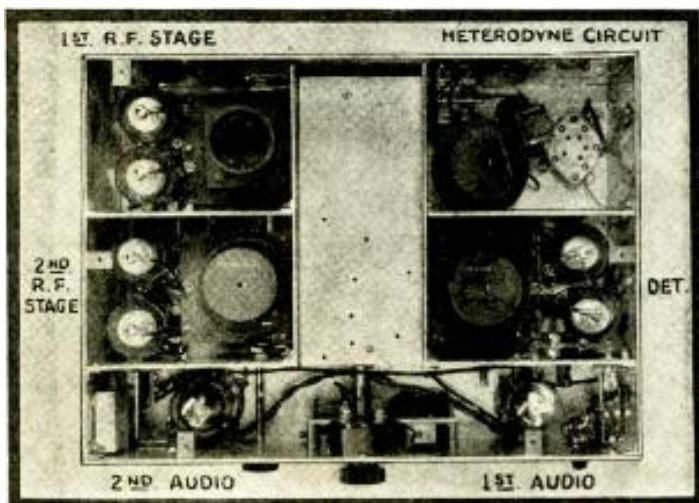

Fig. 6—Top and bottom views of Mr. Marshall's short wave receiver, showing R.F., detector, audio stages and heterodyne circuit. Set may be used as an autodyne or neutrodyne receiver.

S-M 727 - Introduces A New "ALL-WAVE" Principle

By McMURDO SILVER*

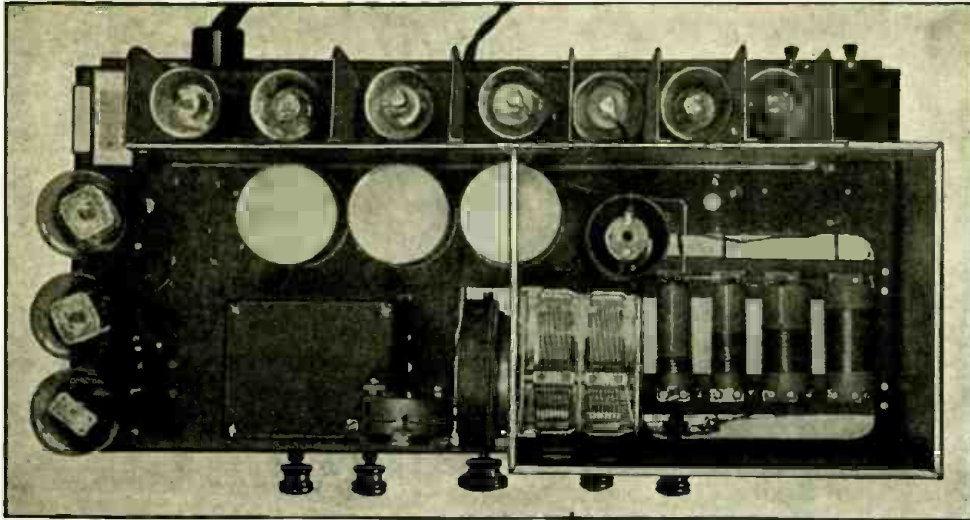

Fig. 2—Top view of new 10 tube Silver-Marshall All-Wave "Super-het," Model S-M 727, with cover of "coil shield compartment" removed.

IN this article is described a receiver embodying what in certain respects may be termed a basically new development which it is sincerely believed will effectively revolutionize the design of wide band receivers, such as combination short and broadcast band sets.

This new principle, the development of McMurdo Silver and Kendall Clough, is very interesting for it has the simplicity of all really important basic developments, and while totally new, is ridiculously simple and obvious, and is the subject of basic patent applications. At one fell swoop it eliminates the major portion of the band switching required in multi-range sets, reduces costs very considerably, and most important of all, makes short wave tuning as easy and simple as broadcast band tuning is today, since for the first time it permits absolutely accurate logging of the short wave tuning dial at the factory—something that in the past has been possible only at such excessive expense that it may safely be said to have been impossible commercially.

Upon the introduction of the eleven tube short-wave and broadcast superheterodyne known as the S-M 726SW last June, it was felt that it was the last word in short wave and broadcast receiver design. Its performance has more than proved that this belief was correct and today many thousands of these sets in almost every country in the world are giving satisfaction. While relatively simple in relation to its performance, it was not as simple as could be desired, but no means was known which would permit, for instance, of a simpler coil selecting arrangement, or which would eliminate certain unpleasant, but not really detrimental sounds, of the nature of "burps"—which occurred as the short

Simple, accurate tuning and "logging" of short wave stations is at last made possible by a new tuning method, which involves the use of an oscillator and a "harmonic generator." Data on the coils and condensers used to accomplish these results are given. This receiver is a powerful 10-tube "super-het" operating on A.C.

wave dial was tuned, because of unavoidable reactions between harmonics of the broadcast and short wave oscillators. Since no method was known for eliminating these two drawbacks, since they were only slightly unpleasant rather than really detrimental, and as the performance obtained from the set was so far superior to that obtained from previous short wave sets, it was believed that nothing better could be hoped for.

Mr. Clough's Discovery

During the course of development work in an attempt to devise a better, or at least a simpler, system, some experimenting was done with autodyne first detectors, and while nothing satisfactory resulted, an idea was found, by Kendall Clough, Chief Engineer of S-M., which now fully worked out, is probably one of the greatest contributions to short wave receiver design that has so far been developed. It at once simplifies the tuning of short wave superheterodynes, eliminates most of the switching necessary in sets not employing plug-in coils, now practically obsolete anyway, and does away with all "burping" on short waves due to oscillator reactions. Six months ago this method had not even been dreamed of—today it is a practical, oper-

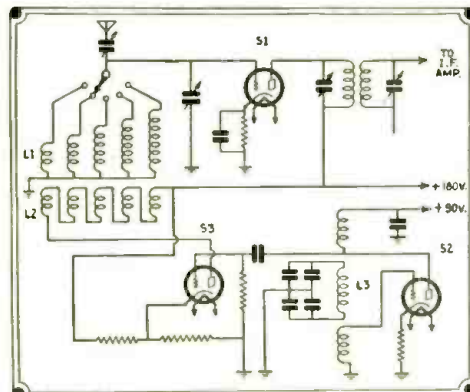

Fig. 1—All-wave "super-het." S1 is first detector; S2—oscillator tube and S3 the "harmonic generator" tube.

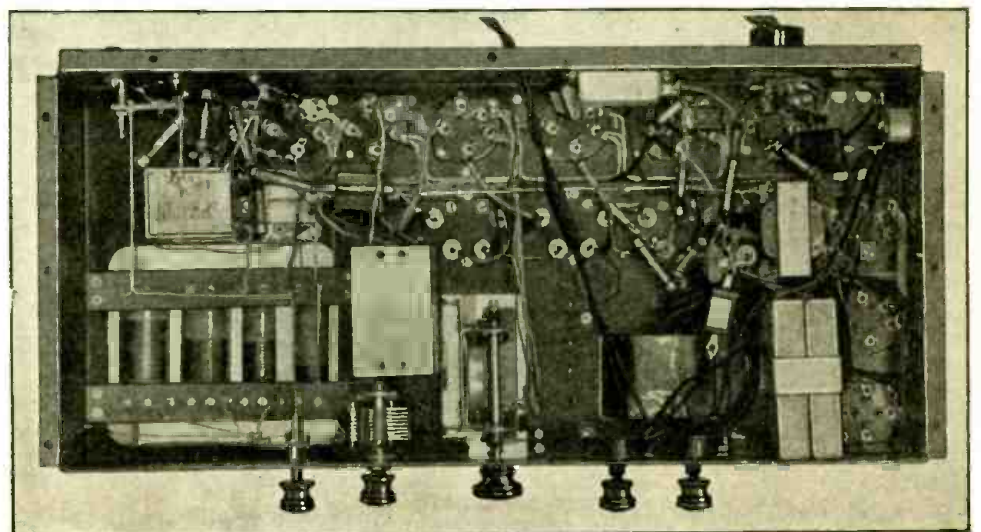

Fig. 3—How bottom of S-M 727 looks, with the cover removed. This is a super-selective receiver that "picks a real wallop" on all wavelengths.

* Pres., Silver-Marshall, Inc.

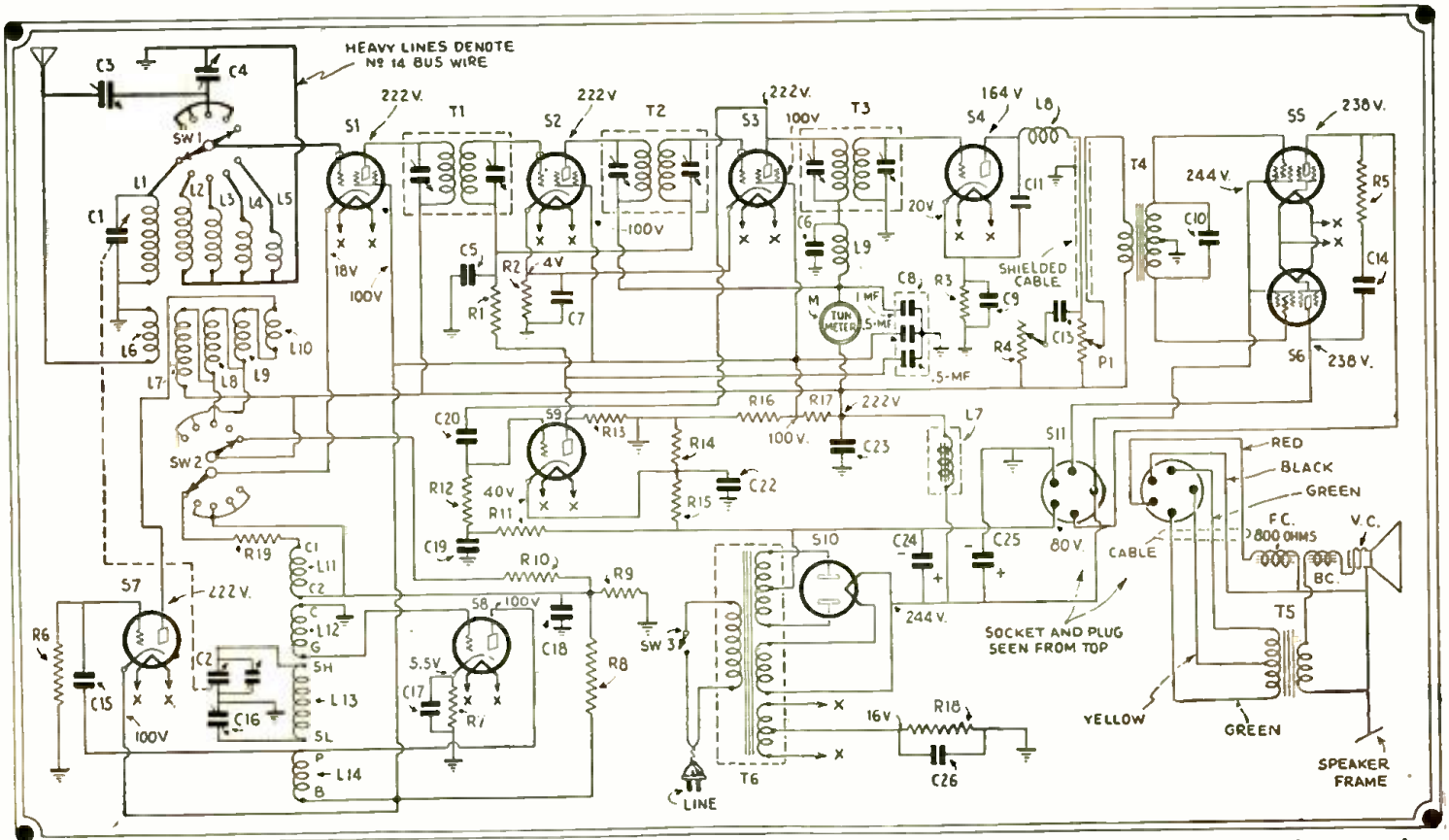

Fig. 4—Wiring diagram for new All-wave Silver-Marshall Super-heterodyne designed for operation on 110 volt, 60 cycle A.C. circuit.

ative reality in several thousands of sets now in use.

While the autodyne detector system appears attractive at first glance, it has two drawbacks which render it worthless in a super. The first is its absolute inability to discriminate against *image frequency* interference, since every signal is impressed directly on the one tuned circuit of the combined *oscillator-detector* tube. The second drawback is that, since this circuit must be tuned away from the signal frequency by the intermediate frequency to produce the necessary heterodyning action, and as on short waves this I.F. will be quite high, much loss of signal voltage results, particularly on the lower signal frequencies. The autodyne system is quite simple, but the new Clough system is equally simple, has none of the autodyne's drawbacks, and is in no sense related to the autodyne system, since it employs a separate and distinct detector and oscillator with their separate tuned circuits.

How Oscillator and Harmonic Generator Are Used

The Clough scheme is to use only one oscillator in the set, which must tune from 16.5 to 550 meters, or 18,000 to 550 kc. This is impossible, for even the harmonics of the oscillator are too weak to be of direct use. The crux of the idea lies in the use of a tube directly coupled to the oscillator, which is so set as to tune over the broadcast band of 550 to 1,500 kc., this tube acting as a *harmonic generator* and providing the necessary local frequencies to heterodyne signals in the 16 to 35, 35 to 65, 65 to 100 and 100 to 200 meter short wave bands. This system results in only one permanently connected and aligned oscillator circuit, the harmonic generator tube providing the required heterodyne voltages

for the short wave bands. A single selector switch knob gives a choice of five separate coils to enable the first detector to cover the four short wave and broadcast bands. In the final embodiment, one dial tunes the broadcast band; this same dial, plus an auxiliary trimmer, tunes the short wave bands, and one *five-position* switch selects the five bands at will!

Sensitivity of Receiver

Before describing the features of the system it may be well to allay skepticism by stating that the receiver illustrated and described herewith embodying this new system shows a broadcast sensitivity on the order of better than two to three microvolts absolute input for standard output, absolute 10 kc. selectivity with no image frequency or cross-talk interference, a fidelity curve from antenna to ear flat to a few decibels from 40 to 4000 cycles, and five to six watts of undistorted power output—so there must be merit to the Clough system, even if it is brand new.

The salient points being many and

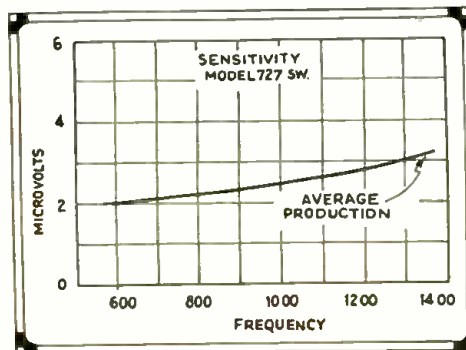

Fig. 5—Curve showing sensitivity of new receiver.

closely interrelated, it is a little difficult to present them simply and concisely. One of the first points, for example, apparently having little bearing on the oscillator harmonic generation idea—is the choice of intermediate amplification frequency. Since only one is used, as against two in practically all other short and broadcast band sets, for instance, it must be selected carefully with respect to both broadcast band and short wave operation. The supposedly ideal broadcast band intermediate frequency of 175 kc. is almost worthless below 200 meters, and the next logical step is to 465 kc., which gives the advantage of "one spot" operation over all but 2% of the broadcast band, (1480 to 1500 kc.), as well as being very satisfactory for short wave reception. 465 kc. for the i.f. simplifies image frequency, or repeat spots, interference in the broadcast band to a point where it can be handled nicely by one high-Q tuned circuit ahead of the first detector, as compared to the two tuned circuits invariably needed with a 175 kc. i.f. amplifier. This is a considerable gain in simplicity, but brings in another problem, that of i.f. harmonic feedback from the second or audio detector, which will appear at multiples of the intermediate frequency, or 930 and 1395 kc. in the broadcast band. By careful arrangement of parts and filtration, this can be eliminated, and no "tweets" will be apparent on the broadcast dial at these frequencies.

Throughout the 550 to 1500 kc. broadcast band the arithmetic selectivity is not as high as might be desired, but it is adequate with today's improved engineering technique of i.f. amplification, and it is very good on the short waves. A 465 kc. i.f. permits also of entirely adequate image frequency selectivity on short

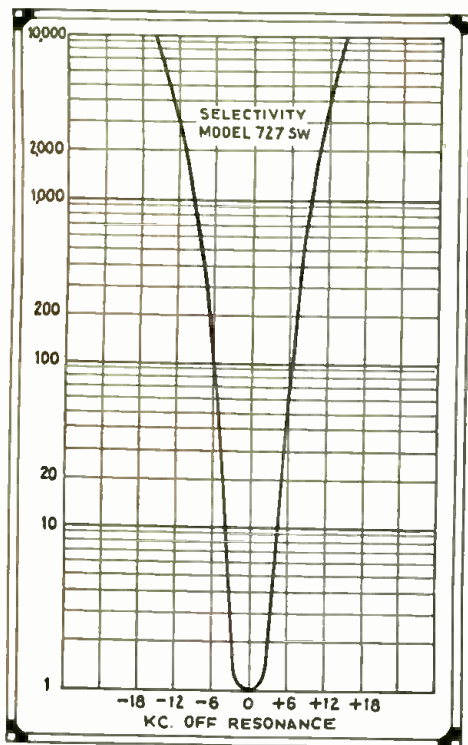

Fig. 6—Curve showing excellent selectivity of new S-M "All-Wave" Super-Het.

waves, the frequency separation at 20 meters, for instance of the two oscillator settings serving to heterodyne a given signal being 6%, which may be satisfactorily discriminated between by one high-

Q tuned circuit ahead of the first detector as has been proven in practice.

Explanation of Harmonic Generator

Fig. 1 shows in diagrammatic form a simplified example of the *harmonic generator* arrangement used to produce the short wave heterodyne frequencies. S1 is the '24 screen grid first detector tube, with its tuned input circuit represented by five coils, all designated L1, selected by the five point switch to cover the five different bands, and tuned by the condenser C1. S2 is the oscillator tube, L3 representing its plate, tank tuning, and grid coils. S3 is the harmonic generator tube, across the plate coils of which, L2, is developed the required short wave heterodyne voltages, the coils L2 each being properly coupled to the short wave coils L1.

For broadcast operation, one set of L1 coils covers the band of 550 to 1500 kc., and the fundamental oscillator range is therefore the sum of these limit frequencies plus the i.f. of 465 kc., or 1015 to 1065 kc. The oscillator is coupled to the first detector by a coupling coil not shown in the diagram of Fig. 1 for simplicity, and serves to heterodyne all broadcast signals to 465 kc. for the i.f. amplifier. When so used the harmonic generator tubes S3 is not utilized, but is not cut out of operation, this being unnecessary. If the band selector switch is now turned to the second L1 coil, the useful tuning range of the first detector will be about 90 to 200 meters, and the oscillator is obviously useless to heterodyne signals in this range to 465 kc. But now the harmonic generator tube S3 is utilized,

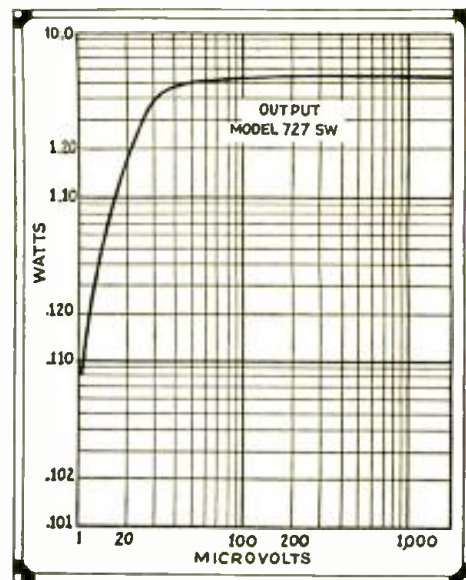
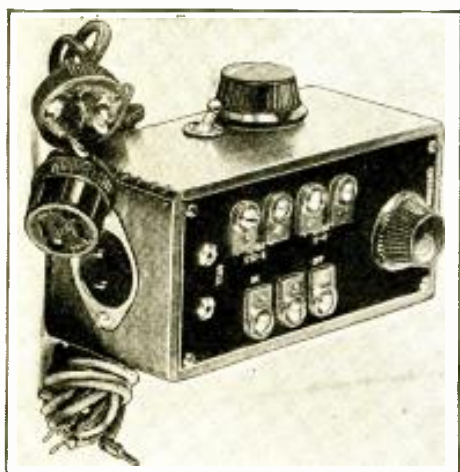

Fig. 7—Power output in watts plotted against microvolts input—showing fine work of "automatic volume control."

and its grid circuit, directly coupled to the oscillator plate circuit, is fed frequencies in the range of 1015 to 1965 kc. by the oscillator. S3 is biased well below its cutoff point so that it draws no plate current when not fed by the oscillator, and acts as a rectifier, or more properly, as a frequency multiplier. In its plate circuit, therefore, will appear a multitude of multiples of the oscillator frequency.

(Continued on page 419)

The Luxtron Selenium Cell and Relay



Complete light-sensitive cell and relay.

EVERY experimenter, at one time or another, has had a hankering to put a light-sensitive relay to work. Heretofore, these light-sensitive devices have cost a considerable amount of money, but the new light-sensitive cell and relay shown in the accompanying photographs and made by the Luxtron Device Co., is very nominal in cost. The selenium cell illustrated is known as the "S.T." type and it is made by an improved technique so as to operate in a very rapid manner. It is not intended for operation in television circuits but it has a thousand and one applications in the field of electro-mechanical control. Whenever a light is flashed on the selen-

ium cell, the relay instantly closes, so that a 110 volt or other lamp circuit can be opened or closed. The "S.T." selenium cell is designed and built to change its electrical resistance sufficiently to operate a relay, when under the influence of a strong light, on voltages between 3 and 22.5.

The voltage required in series with the cell and relay depends, of course, upon the strength of the light flashed upon the selenium cell. This cell is guaranteed by the manufacturers to give a minimum of 2 milliamperes when a 40 watt frosted

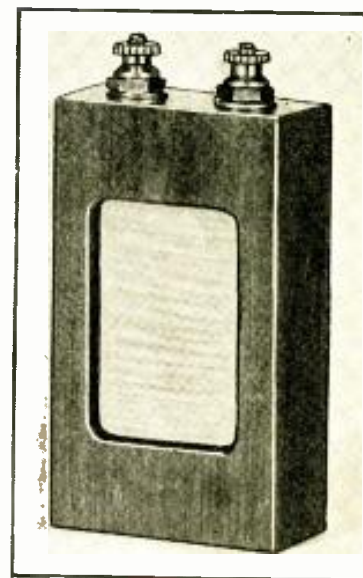

The new selenium cell.

lamp is held in front of the cell at a distance of 12 inches. When indirect sunlight is applied to the cell, a current as great as 25 milliamperes and more is obtained.

This selenium cell will operate any relay having a resistance of 1,000 ohms or more, the manufacturers state. The selenium cell and relay are mounted in a handsome wood cabinet, with an adjustment for the relay projecting from the side of the box.

In Our Next Issue!

HOW TO BUILD
A
**"Police Call"
Thriller**
That
Provides the Greatest
EVENING'S
ENTERTAINMENT
You Ever Heard!

Attaches to your Regular Broadcast Receiver and converts it to receive the "Police" Short Waves.

Short Waves for the Broadcast Listener

A SHORT WAVE ADAPTER

By W. BURMEISTER

THE supplementary set is built according to the Leithäuser hook-up. It can be operated with any radio receiver (long wave type), if the detector tube of the radio set is removed and the plug of the adapter is inserted in its place; the heater and plate potential are therefore furnished by the radio set. It is directly adaptable to use with battery sets; with all-electric sets, on the other hand, it can only be used if well-filtered plate potential is available. A similar set was operated successfully about a year and a half; the rectification potential amounted to 390 volts, while the detector plate potential was reduced by resistances to about 20 volts. Raising the potential at once brought a light hum, which could not be removed even by chokes.

The wave-band change switch has three switching positions:

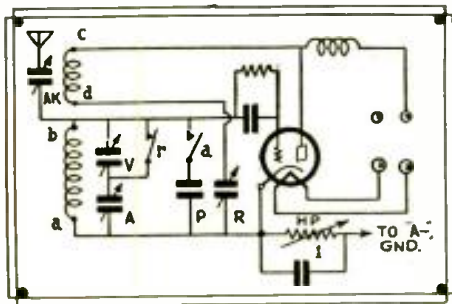

Circuit diagram of the short wave "adapter", which can be plugged into the detector socket of the average broadcast receiver.

1. Series condenser V (35 mmf., short-circuited by r, parallel block condenser P, switched off by a, (with 4 coils: 19 to 90 meters, see table).
2. V switched in by r, P switched off with 20 meter coil: 20 meter band.
3. V short-circuited by r, P switched on, 40 and 80 meter coils: 40 and 80 meter bands.

The switch springs are relay springs with silver contacts. The switching is done by a switch roller, which has on its circumference two screws set at 120 degrees apart; the stopping is done by a triangular piece of brass with a spring pressing on it. (Switching from one band to another requires about 5 to 7 seconds.)

The 80 meter band is drawn out sufficiently far, even without the parallel block condenser (40 degrees on the 100 degree scale, equal 75 to 85 meters). Attention should here be called to the fact that in some countries work is done even below 80 meters, i. e., in the United States. In the case of the 40 and 80 meters the regeneration is regulated by the 100 mmf. condenser "R"; in the case of the 20 meters on the other hand by a 50,000 ohm potentiometer. The potentiometer was put in the negative wire, to

save insulating the shaft. With predominant battery control it must be put in the plate wire, however, since otherwise it is switched out.

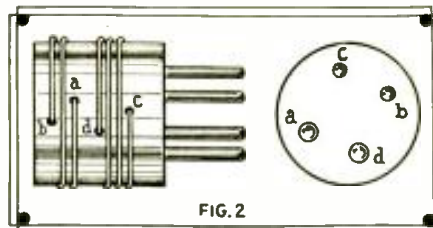

This drawing shows how the "plug-in coils" may be wound on tube bases or bases on which bakelite or other tubes have been snugly fitted.

connection. The negative connection to the long wave set is made by sticking a piece of sheet metal into the shielding. When using the socket of an old indirectly heated tube the middle prong can be used for this. In the case of battery tubes this connection must be made to a heater battery pole.

By regulating the plate potential the tuning change on 20 meters becomes so slight that the station adjusted for remains in the range of hearing. Parts used:

- Tuning condenser A (50 mmf.)
- Regeneration condenser R (100 mmf.)
- Series condenser V (35 mmf. Neutro-condenser or X-L screw-adjusted condenser)
- Potentiometer HP (50,000 ohms)
- Antenna coupling condenser AK (35 mmf. Neutro-condenser)
- Grid (air) blocking condenser 250 mmf.; grid resistance 2 to 3 megohms
- Parallel air block condenser P 100 mmf. 1 microfarad block condenser, test potential 500 volts
- Tube and coil holders (home-made)
- Wave switch (home-made)

Coil Table

Coil	Wave Length Approx.	No. of Turns.	Wire B. & S. Gauge.	Distance Between G. & R. Coils.	Coil Length.
1	19-30 m.	G=7.5	22 D.C.C.	.06 inch	.3 inch
		R=11.5	28 D.C.C.2 inch
2	29-43 m.	G=12.5	22 D.C.C.	.02 inch	.48 inch
		R=11.5	28 D.C.C.2 inch
3	40-60 m.	G=18.5	22 D.C.C.68 inch
		R=14.5	28 D.C.C.24 inch
4	60-90 m.	G=25.5	28 D.C.C.44 inch
		R=18.5	28 D.C.C.32 inch
5	40 m. band.	G=9.5	22 D.S.C.	.12 inch	.34 inch
		R=10.5	28 D.C.C.22 inch
6	80 m. band.	G=17.5	26 D.S.C.	.06 inch	.38 inch
		R=18.5	28 D.C.C.34 inch

G = Grid coil; R = tickler or plate coil.

Attention must be called to the fact that in every case an exact balancing must be carried out again. The table is just to give points of departure. The antenna used was a 40 meter "L"-antenna.

Building the Set

A sub-base and front plate .08-inch aluminum was chosen, to remove hand capacity completely. Below the sub-base are put the 1 microfarad block condenser and the terminals for the plate potential and negative connection. This is likewise insulated from the sub-base. The set has these dimensions: front plate, 5x7 inches; sub-base, 7x7 1/4 inches. The tube and coil holders are home-made and installed on a plate 1 1/2 x 4 inches. The sockets are replaced by strips of brass .08x.24 inch; (small socket capacity!) By cut-outs solid construction is avoided. The cathode connection of the tube runs over a brass socket to the base plate and over the potentiometer to the negative

High frequency choke (.92-inch diam., No. 32 B. & S. gauge double silk wound wire, winding length about 2 in.) For 20 meters it is better to use a smaller choke, to obtain higher high frequency resistance.

The sound intensity furnished is good. —Funk Bastler.

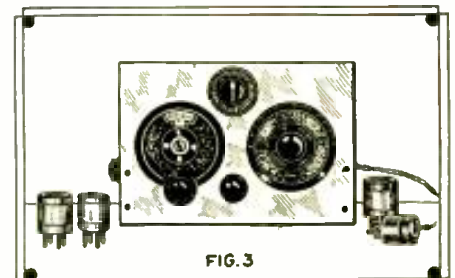

Front panel view of short wave "adapter" here described.

BUILDING A Short Wave SUPER - HET

By A. POLTHEIM

One of the latest European ideas in short wave superheterodyne receivers is here described by the author. It uses a minimum number of tubes with a "pentode" output tube. In fact this "super" seems to be a long jump ahead of all others.

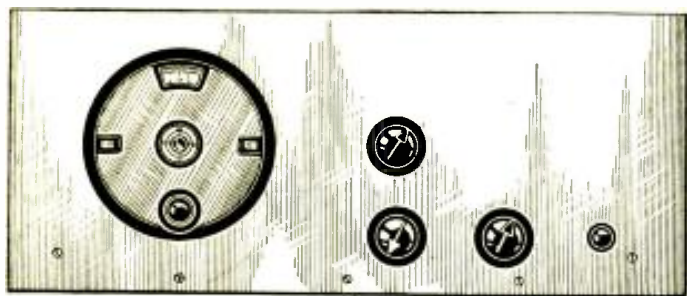

Front view of S-W super-het.

THE short waves offer the possibility of receiving the most distant stations perfectly. Right in the summer, when the reception conditions in the broadcast radio field are very bad, in the short-wave field a great number of stations can be received with excellent volume. There is the added fact that, lately, the number of S.W. stations to be heard has increased greatly; so that the practised fan has at his disposal a fairly rich selection. It is therefore comprehensible why the interest in short-wave reception has greatly increased.

Super-het the Ideal Receiver

Although astounding results can be attained with the simplest means, for dependable reception, satisfying the highest demands, a highly-efficient receiver is necessary. Just as in other wave ranges, the superheterodyne may be regarded as the ideal type of receiver for short waves also. In the first place, it has a reserve of amplification, which cannot be used at all for many stations but is extraordinarily useful as a reserve for poor receiving days or for very weak stations. No less important is its easy and simple operation, even on the shortest waves, as well as high selectivity. This last is necessary, in order to be able to tune out the numerous telegraphic stations, which often have almost the same wavelength as radio-telephone stations.

Autodyne First Detector

The short-wave super can be simplified, for receiving waves up to 100 meters at most, in both construction and operation, as compared with the super for ordinary long waves.

A special oscillator, and the oscillator control, can be directly done away with. The modulation necessary for producing the intermediate frequency can be attained in a most simple way, with a permanently-oscillating input tube (autodyne first detector) by detuning the tuning circuit. As proved by measurements, detuning the receiver circuit 2 per cent at most, with regard to the transmitter frequency, is admissible without essential loss of energy. With an intermediate-frequency wave of about 5,000 meters, a frequency difference between the sender and the oscillator of 60 kilocycles is necessary. If this is not to exceed 2 per cent of the carrier fre-

quency, the lowest admissible receiver frequency is $\frac{1000}{0.02} \times 60 = 3,000$ kilocycles. Therefore, the highest receivable wave must not exceed 100 meters. Most short-wave broadcast stations, however, lie considerably lower, between 15 and 50 meters; so that for them still more favorable conditions result.

Stations Received Without Whistle

Adjusting the receiver is limited to manipulating the tuning condenser, and setting the regeneration and volume controls. As with every super, here too the stations come in without a heterodyne whistle. To get heterodyne reception, a second regenerative coupling must be provided. This is indeed necessary only for telegraphic (code) stations; but the "undamping" caused by the regeneration considerably increases the volume of sound. The input is through the intermediate-frequency tube.

In Fig. 1 the complete hook-up of the receiver is shown. There are four tubes; two being screen-grid tubes, and one a three-grid (pentode) tube. The input stage is connected like a normal detector, and has a screen-grid tube. Its func-

tion is double; it works simultaneously as oscillator and modulator (autodyne), and produces the intermediate-frequency wave. The feed-back or regeneration is according to the Weagand circuit in which the tickler coil is between R.F. plate choke and the filament or cathode. Therefore, the two rotary condensers, C1 and C2, have a common connection at the cathode, so that "hand capacity" completely disappears with a thorough grounding. As a precaution, they are mounted at a distance from the front panel. The tuning condenser C1 is a good, stout short-wave type of from 100 to 200 mmf. capacity. To be sure, higher values give a greater wave range, but they render the tuning more difficult and are therefore not to be recommended. The regeneration condenser C2 is 200-300 mmf. Here one can use a good midget condenser with mica or other dielectric. The antenna has aperiodic or untuned coupling; to be able to change the degree of coupling also, by changing the antenna coil L3, the latter is so arranged that it can be turned about.

In the plate circuit lies the radio-frequency choke RFC; it is not very critical and, if well made, does not require interchanging. The screen grid

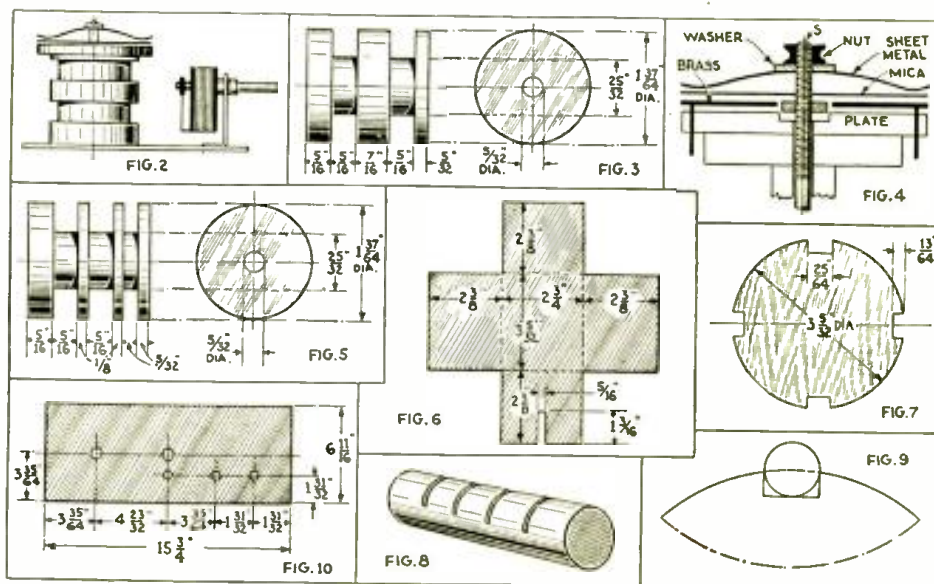

Various details and dimensions of coil and condenser parts used in constructing the S-W super-het.

gets about half the plate potential and is by-passed to cathode by a condenser of 0.1- to 0.5-mf.

Intermediate Frequency Filter

After the radio-frequency choke we find in the plate circuit of the input tube, the intermediate-frequency filter F. Its primary and secondary are tuned by small variable condensers to the intermediate-frequency wave (about 5000 meters) and are loosely coupled. The secondary is across the grid of the intermediate-frequency tube and the slider or arm of a potentiometer, by varying which the grid voltage of the screen-grid tube is altered; and thereby, also, the amplification can be regulated within wide limits. To avoid self-excitation of the tube, the slider must be bypassed to one side of the filament by a 0.5- to 1-mf. condenser. The potentiometer has a resistance of 400-1000 ohms. The screen grid gets its potential in common with the first tube.

The second intermediate-frequency transformer differs from the filter, in the closer coupling of the two coils; and it also has an untuned primary. Likewise, this tube is connected according to Weagand's method.

The audio-frequency stage is coupled via a transformer, having a ratio of from 1:4 to 1:5. The primary is shunted by a .001-mf. condenser. It is practical to use a three-grid (pentode) tube, which gives high amplification. Then the loud speaker must be shunted by a fixed condenser of .005- to .01-mf. capacity. One can also use an ordi-

nary output tube, when the condenser need be only .001- to .002-mf.

Parts Can Be Home-Made

Almost all necessary parts can be home-made. The most difficult work, requiring great care, is making the intermediate frequency transformer and the

secondary windings fit in the two grooves. The number of turns is 2,000 each, of No. 34 silk-enameled wire. To avoid wire breaks, the ends are strengthened by thicker wire and run out through small drill-holes.

The trimmer condenser is made in the following way (Fig. 4): on the coil body

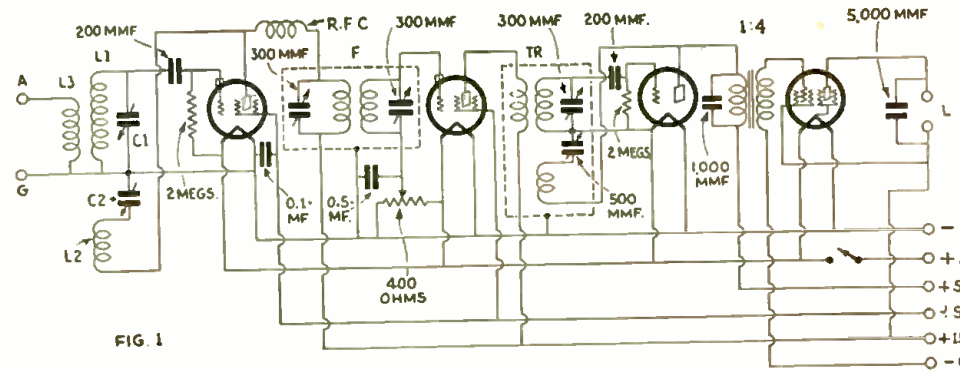

FIG. 1

Diagram of Mr. Polheim's short wave superheterodyne.

filter. The filter construction is shown in Fig. 2. On a base board of wood 2.8 x 3.2 inches, and 1/4 to 5/8 inch thick, there is a midget condenser of 300 mmf., mounted by means of an angle iron so that its shaft projects out above it. Beside this is fastened the coil body, which bears at the top the midget (trimmer) condenser necessary for finer tuning. The body is made of wood, hard rubber, or fiber, exactly according to the dimensions of Fig. 3. The primary and sec-

a square insulating plate, 2 inches on a side, is fastened by means of a screw S which runs through the coil core. The nut must be so sunk that it does not come in contact with the brass plate laid over it. To fasten the latter, small pins are inserted in two corners, which at the same time form one connection of the condenser. They are put in suitable holes in the insulating plate. On the brass plate is laid a mica plate .008- to .012-inch thick. As the second condenser plate, there is then mounted a slightly arched sheet of brass .008-inch thick, which is pressed down by the upper nut and the extra disc (or washer). The capacity is altered by varying the pressure. After assembling the filter, the coil ends are run to the condenser connections and, at the same time, there are soldered on 8-inch wires, covered with spaghetti.

Transformer Details

The transformer is built similarly. The core has the dimensions given in Fig. 5. Primary and secondary are separated only by a wall 0.12-inch thick. There is likewise provided a third groove, 0.16-inch wide, for the regenerative winding. The number of turns of the primary and secondary are likewise 2,000 each, of the wire named above. (Same as for the filter.) The tickler L2 has 700 turns. In connecting the ends, pay attention to the correct polarization of the windings. With the coils wound in the same direction, the outer end of the secondary is connected with the grid, the inner with the plate of the intermediate-frequency tube. Like the filter, the transformer also has a leaf (midget) condenser tuning the secondary, and a midget condenser, which however is .0005-mf. Matching the transformers requires some calibration, usually not at the disposal of the amateur; therefore, give this work over to a laboratory.

Filter and transformer must be completely shielded. For this use sheet brass, aluminum, or zinc shields 2.8x3.2x2.4 inches. From the sheet metal two pieces are cut out as in Fig. 6, and are bent at right angles on the dotted lines. Then the joined edges are soldered inside, with plenty of tin, and rounded on the outside with file and emery paper. Then the shields are lacquered. Do not

(Continued on page 426)

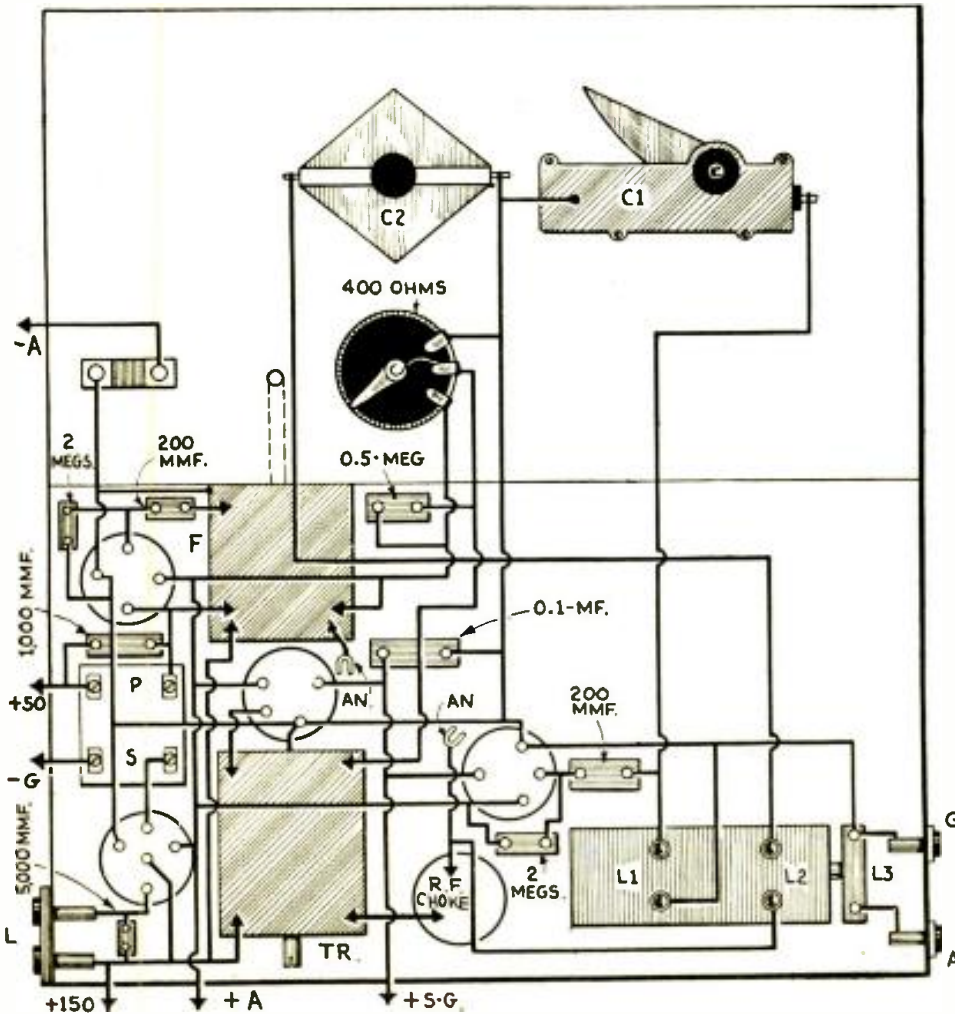

Physical wiring diagram of the Polheim S-W super-het.

The MIDWEST S-W CONVERTER

By W. A. SMITH*

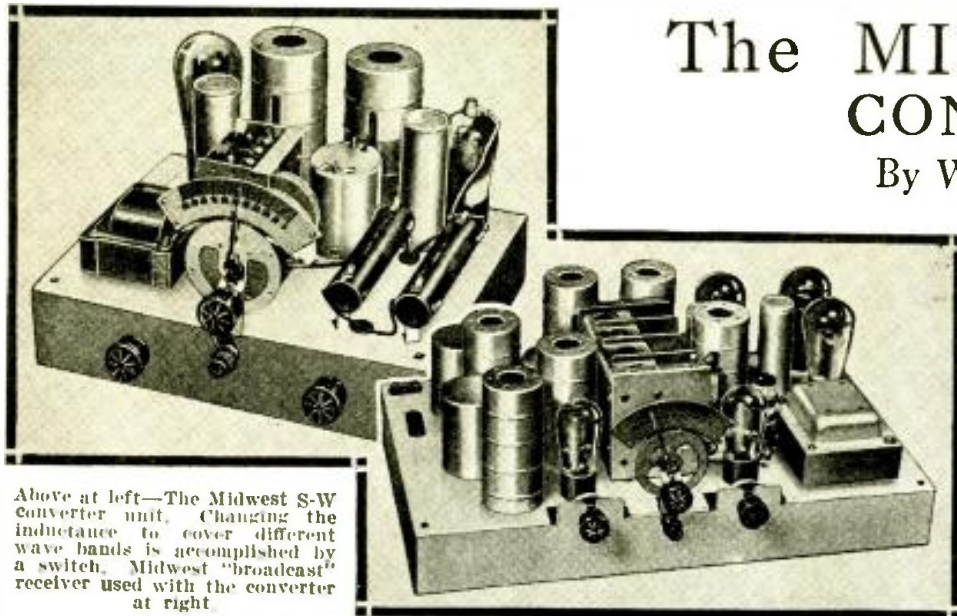

Above at left—The Midwest S-W converter unit. Changing the inductance to cover different wave bands is accomplished by a switch. Midwest "broadcast" receiver used with the converter at right.

These adjustments are broad enough so that he can select frequencies up to 540, which is just outside of the broadcast band and might be an ideal point for him to operate provided he can meet it on his radio set.

This changing of the selected i.f. frequency requires a corresponding change in the relation between the oscillator circuit and the r.f. tuning, and the "trimmer" condenser must be large enough to compensate for this change.

Coil Requirements

We now have our coil requirements pretty well in mind. The r.f. coil should be tuned by the variable condenser for

THE short wave converter has arrived. The demand has been produced by a great amount of publicity, more or less based upon facts but mainly based upon the consumer's imagination. The idea of tuning in European stations has caught the fancy of the Broadcast Listener. This demand must be supplied.

New groups of engineers are attacking the problem daily. New ideas are being tried, new circuits evolved, new names coined. The result is a state of chaos in the mind of the consumer and an absolute lack of uniformity in the product.

Similar conditions existed in the early days of the automobile. Various types of machines, more or less patterned after the buggy, phaetons, etc., were evolved. Most of them ran for short distances over the poor roads existing at that time, but a good time was had by all present. Some day we will tune in any city easily and at will. At present, the roads are rarely open and one has to know many details that properly belong only in the laboratory.

The idea of the converter is the same as if a gasoline engine were attached to a buggy and geared to the wheels, such as the earlier autos. However, the broadcast listener demands this engine and we "kotow" to him. The following means of designing and testing of short wave converters has recently been evolved.

Self-Contained "B" Supply Desirable

It is assumed that the converter should be of the self-sustained type and that it should contain all of the materials and of such quality as is necessary to produce the results expected under favorable conditions of course. It is therefore necessary that this converter should contain its own power-pack and should feed energy to the radio set and subtract nothing from it. For this reason both A and B supply units are included in the design.

It is further assumed that the converter should be of the Super-Heterodyne type which reduces the high frequency signals to a uniform frequency, which may be efficiently handled by the radio receiver. There remains then the following question: What frequency should be chosen for amplification by the broadcast set?

* Chief Engineer, Midwest Radio Corp.

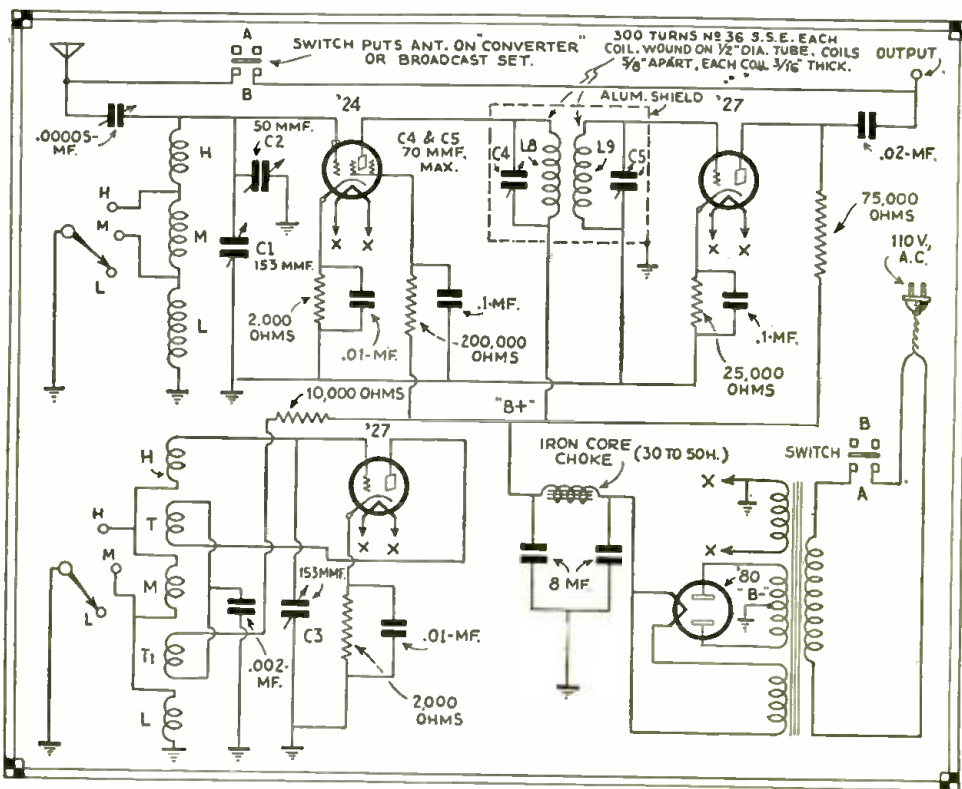

The Midwest S-W converter circuit is shown above; the "output" post connects to "aerial" post on broadcast set; chassis is grounded to "G" post on "B.C." set.

Intermediate Frequency

Assuming that a modern broadcast set of the highest quality is to be used, the choice does not rest with the matter of selectivity, because these sets are rarely sensitive all over the band; the only other choice is one of selectivity. It is well known that sets are more selective at the low frequencies and that the modern broadcast set is better able to find a clear spot between stations at about 90 than at any other point on the dial. It is for this reason that the intermediate frequency was chosen at about 575 kilocycles.

In the event that the customer cannot find a clear spot at this point on account of local stations, he should be able to efficiently operate at some other frequency and provisions are made for this by having the "i.f." transformer on the converter of the top adjustable type.

200 meters to as low a point as is possible and desirable. Experience shows that the 80 meter "ham" band can easily be included in this first point on the switch. Correspondingly, the oscillator coil must cover this same band, plus 575 kilocycles, the intermediate frequency.

The second point on the switch should begin at this 80 meter point with a slight lap and again carried down as far as possible, and this is known to be about 35 meters. Correspondingly the third point should begin with a slight lap and go down to at least 15 meters, and this is possible; the only question remaining is how to be sure that we are actually accomplishing this.

After many experiments with wave meters and signal generators available, the following procedure was established. A tuned radio frequency set was established at its lowest frequency by tuning

Letters From S-W Fans

HE CAN'T BELIEVE HE HEARD VK2ME

Editor, SHORT WAVE CRAFT:

"Here for New England" I honestly think SHORT WAVE CRAFT is the best magazine ever put out for the "short wave" fan. I have every copy and refer to them often.

Mine is a battery model Super-Wasp and here are some of my verified stations: PCJ, PCK, PCV, G58W, GBU, GBS, GBC, 3RD, Zeesen, FW, HS2PJ, HRR, HKC, VRY, VE9GW, VE9CL, VK2ME, etc.

Here is a funny one: Last Saturday morning, March 28, at about 6:20 A. M., I was strolling on the dials at about 30 meters. As I approached 31 meters I heard a signal. I tuned it in and said to myself, "here's W2XAF testing." Organ music was coming in fair; then, to my surprise, the announcer said in English, "we now sign off at 9:23 P. M. Victorian time. This is VK2ME at Sydney, Australia." That's too good to happen every day. If it was the first of April I wouldn't believe it.

Sincerely yours,
LEON F. LAVOIE,
77 Rollstone St.,
Fitchburg, Mass.

(We like your modesty, Leon, but we really believe you heard VK2ME, although there is a chance that it was a rebroadcast but you can easily find that out by writing to the General Electric Co., of Schenectady, N. Y., and ask them for verification. If you give them the exact time and data, they should be in a position to check you up.—Editor.)

A FINE SUGGESTION

Editor, SHORT WAVE CRAFT:

I am a charter subscriber to SHORT WAVE CRAFT and I think that each issue is bigger and better than the one before.

I have seen diagrams of two-tube regenerative and four-tube regenerative sets whose parts came from the "junk box" but as yet I have seen no superhets whose parts come from here.

I would like to use the new two-volt tubes as the nearest power line is a mile away. I think there are still a large number of fellows who don't have A.C. as yet and would be interested in this kind of a superhet.

I am glad you reduced the price of SHORT WAVE CRAFT but I wish it came every month, instead of every other month.

Sincerely yours,
RALPH MILLER,
Wellington, Ohio.
R. F. D. No. 4.

(That's what we call an excellent suggestion. Sometimes the editors have their noses so close to the machine that they overlook the best ideas, and that is where our readers come in. The short wave superheterodyne junk box is already "in work". It will appear soon. Now you readers put your heads together and "holler" for more.—Editor.)

FROM LATVIA

Editor, SHORT WAVE CRAFT:

We heartily welcome the appearance of your SHORT WAVE CRAFT here. You have well gauged the interest for such a magazine and I think your issue must be enormous.

It is with special interest that we, the local amateurs, have found the name of Mr. Somerset (G2DT) on the pages of your magazine, a name which was known to us through the *Radio News* and other magazines. Mr. Somerset enjoys with us the greatest esteem as author of sketches and instructions which always prove to the point in constructing an apparatus and avoid trouble and disappointment, what cannot be said of many other authors.

We, the Baltic radio clubs and amateurs, express the wish to see the name of Mr. Somerset more frequently in the columns of the SHORT

WAVE CRAFT. Should your editor's office have anything new by this author in store, kindly let us have same.

Wishing you every success in your undertaking, I remain, Dear Sir,

Yours truly,
DR. V. KUCHARENKO,
Brivibas iela, 14, dz. 5,
Riga (Latvia).

(Thank you so much Doctor, for your nice letter. Yes, we shall try to have more articles by Friend Somerset, who seems to be appreciated in this country as much as in yours.—Editor.)

YEP! 12,500 MILES ON THE "DOERLE" SET!

Editor, SHORT WAVE CRAFT:

First I wish to say that I think that your magazine "sure takes the cake" as far as Short Waves are concerned. I know that the five issues of SHORT WAVE CRAFT I have bought have been worth it; the only trouble is that it is not published every month, and it seems like ages before the next issue. I have built several sets from hook-ups in your magazine and got perfect results! I recommend, by all means, the set on page 258, Dec.-Jan. issue (Doerle). I have built it and got verification cards from VK2ME, G58W, and many QSL cards from "Hams" in all parts of U. S. I have been recently appointed first district manager of International Amateur Radio Society and recommend SHORT WAVE CRAFT to all members. I would like to hear from some other "Hams" and will answer all letters.

Yours, with best wishes for SHORT WAVE CRAFT.

EDWARD J. TRELLA,
547 Broad St.,
Meriden, Conn.
c/o Trella Radio Service.

(If there is one thing that makes an editor's heart glad it is a letter like yours, Edward. Not because you get such good results from a set, but because we take an infantile pride in knowing that sets which we publish and which we recommend really "do their stuff" and do it well.—Editor.)

WE WILL

Editor, SHORT WAVE CRAFT:

I have just completed Mr. Doerle's globe-circler—it works very well—could you instruct me how to add an additional stage of push-pull amplification to it. I think it is going to be a wonder.

Yours very truly
HORACE CREUTZ,
58-46 63rd St.,
Maspeth, L. I., New York.

(A good suggestion Horace, and one which we hope to take up very shortly, and hope you will like the addition.—Editor.)

HOORAY! THE WHOLE WORLD ON 2 TUBES!

Editor, SHORT WAVE CRAFT:

While the boys are telling of their long "DX" records with everything from crystal sets to 15 tube supers I'd like to add a word. Just for fun I built a two tube regenerative, 1 stage audio using tube base coils. After trying it out my four tube, untuned r.f., det., 2 stage audio receiver is now comfortably parked in the basement. When the Dec.-Jan. issue came out it carried a hook-up (Doerle) identical to the one I used save for the choke in the plate lead, which I see is included in this issue's diagram.

Here is my record on the loud speaker using a 200A detector and a 112A audio: W3XL, W8XAL, W8XK, Montreal, Can., W3NAL, W2XAF, W1XAZ, NAA, Hawaiian Broadcasting Co. I have also heard hams on the Eastern

Coast and as far south as Port Arthur, Texas. On the B.C. band I have had XER, Mexico; KMOX, WIL, KWK, WENR, WILAS, WLW on the loud speaker and KXX, KDKA and numerous others on phones. On headphones I have had WCAU, G58W, W9XF, W9XAA, WLO, WMI, W2XE, VE9GW, HKD, W3NAU, and VK2ME. How's that for two tubes?

Keep up the good work with SHORT WAVE CRAFT. I like your idea of listing "STAR" stations.

Very truly yours,
BYRON E. HARGROVE,
479 Hewan Drive, Kirkwood, Mo.

(Here is another endorsement on the "DOERLE" hook-up and evidently it is the "berrier." And believe it or not, the set actually does perk and really has the goods as hundreds of letters which we receive testify. We also receive a number from readers who did not seem to get good results, but we are glad to say that their letters were in the minority. Evidently their sets were not constructed correctly or defective apparatus or tubes were used.—Editor.)

FROM BURMA

Editor, SHORT WAVE CRAFT:

Here I am, the only Keyelleker in Burma, with no one to help or give advice and it would be full of fun to relate how I started this ham-business myself without any aid. But it isn't the place here to give you full account.

I am really very glad to have subscribed to your extremely lively paper; it is really a friend in need, here. The only complaint is that you do not publish oftener than once in two months. Two months!—It's two years to a desolate chap like me, here.

Well, oh, many thanks for your effort in making the "S. W. C." a thoroughbred "ham" paper. I shall look forward with enthusiasm to the forthcoming issues.

Yours faithfully,

VU 2 A C.
MG HLA AUNG,
103 Pagoda Road, Rangoon, Burma.

Shall be glad to correspond with fellow "hams" throughout the ham world; would exchange photos also.

(Though we cannot pronounce your name, here is an American handshake with the hope that you will hear from many of our readers over your way to while away your time. Always glad to hear from the other side of the globe.—Editor.)

ATTABOY

Editor, SHORT WAVE CRAFT:

Your Aug.-Sept. issue of SHORT WAVE CRAFT is the first issue I have read, but I am sure it is not the last. I think it is the best radio magazine on the market for the "Ham" and experimenter.

I have built the one tube short wave set described in your magazine by J. P. Lieberman and in two evenings have logged the following phone stations: W8XK, W2XE, VE9GW, W9XF, W3XAL, W8XAL, XDA, Mexico City, Mexico, VE9CL, and W3XAU. I can run a loud speaker on VE9GW, VE9CL, W3XAL, and W8XAL. This seems rather far-fetched for a one tube set, but nevertheless it is absolutely true. I have also received the following code stations: XDA, Mexico City; TIW, Costa Rica; EIJ, Ireland, and dozens of U. S. stations. I would be very pleased to hear from other "Hams."

Yours truly,
ERIC H. JOHNSON,
P. O. Box 216,
Cudahy, Wisconsin.

(These are the kind of letters we like to see from you "Hams." They make us feel that publishing those articles are not in vain, but help to make us boys happy.—Editor.)

(Continued on page 426)

A 4 to 7 METER RECEIVER THAT WORKS!

By George J. Herrscher, W2APW; E. P. Hufnagel, W2BUK

A super-regenerator that picks up "Ham" and television signals.

DURING the past six months, considerable interest has been aroused in ultra high frequency transmission and reception with the result that there are many amateurs and quite a few commercial stations broadcasting on wavelengths of 3.7 to 7.2 meters.

In this article a receiver which is very efficient will be discussed. We have experimented with several types of receivers and find that the super-regenerative circuit was best adapted to extremely high frequencies.

The receiver described in this article consists of a 237 detector, a 237 long wave oscillator and a 238 pentode audio amplifier. These tubes are used because of their size and because of their quietness in operation.

The main tuning condenser (C3) should be of excellent quality throughout. This condenser is coupled to the full vision dial by means of a flexible insulated coupling and the shaft connecting the coupling with the dial is fiber to prevent body capacity. When the receiver is operating a strong background hiss will be heard on the speaker. When a station carrier is tuned in, the hiss will more or less disappear, depending upon the strength of the carrier wave of the station. In a lot of cases the hiss will entirely disappear. Regeneration is controlled by a 50,000 ohm variable resistor in the plate circuit of the long wave oscillator.

The long wave oscillator oscillates around a frequency of 75 kilocycles. The oscillator coil consists of 2 coils, L3 and L4, L3 having 800 turns and L4 1500 turns. Both coils are "jumble wound" in the same direction, with No. 40 single silk covered wire. (See illustration.)

The detector plate and grid coils consist of 6 turns each of No. 16 Bare wire $\frac{3}{4}$ " in diameter. The ends of these coils are soldered to General Radio plugs and plug into jacks in the supporting bakelite end-plate of the tuning condenser. All detector leads should be as short as possible,

and for this reason a wafer socket is not used for the detector tube. C1 and C2 are both 30 mmf., compensating condensers, C2 being a "band-setting" condenser. The R.F. choke consists of 40 turns of No. 36 single silk covered wire, space wound on $\frac{1}{4}$ -inch tubing. Care should be taken that the choke is kept out of the field of the detector coils L1 and L2. For best results use a vertical antenna from 6 to 10 feet long, although good results have been obtained with an antenna 50 feet long.

Listening to the "hams" operating on the 5 meter band affords one many hours of pleasure. Almost every night you will hear conversations "on the air" just as you would talk over a land telephone. Often you will hear 3 "hams" talking to each other simultaneously.



The super-regenerator which receives amateur and television signals on wavelengths from 3.7 to 7.2 meters—and how!

volts) and also on a good A-eliminator. The plate current has been supplied (in regular reception tests just conducted by the authors) from "B" batteries and the drain is very small, due to the automobile type tubes (6.3 volts heater potential). It is not practical to tune all the way from 4 to 7 meters in one sweep, and we can adjust the compensating condenser C-2 to a certain band, say from 4 to 5½ meters; other bands, say from 5½ to 7 meters, can be provided for by re-adjusting the compensator condenser C-2. The "voice" signal from the N. B. C. station on top of the Empire State Building in New York City now being broadcast on 4 meters has been heard on this receiver (in Newark, N. J.), and also the television "image" signal on 6.8 meters.

The television enthusiast will find this a very good receiver for the "voice" and "image" reception on ultra short waves. If the signal is not quite strong enough

(Continued on page 431)

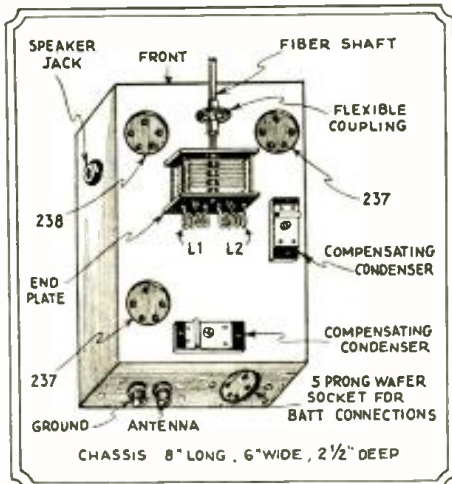

The sketch above shows general arrangement of the parts on the aluminum sub-panel as designed and built by the authors. A short antenna and optional ground wire only are required.

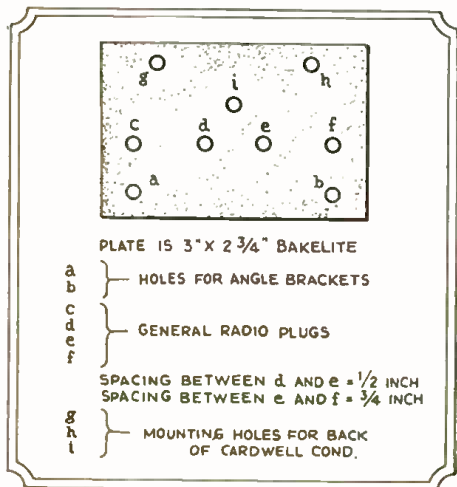

A 5 meter transmitter will appear in the next issue of SHORT WAVE CRAFT.

This super-regenerator in many tests made by the writers yielded a good strong signal on the loud-speaker; the tubes have been operated on batteries (6

Left—Layout of bakelite panel with jacks to receive ultra N-W coils, L1 and L2. Right—Circuit of super-regenerator for 3.7 to 7.2 meter waves.

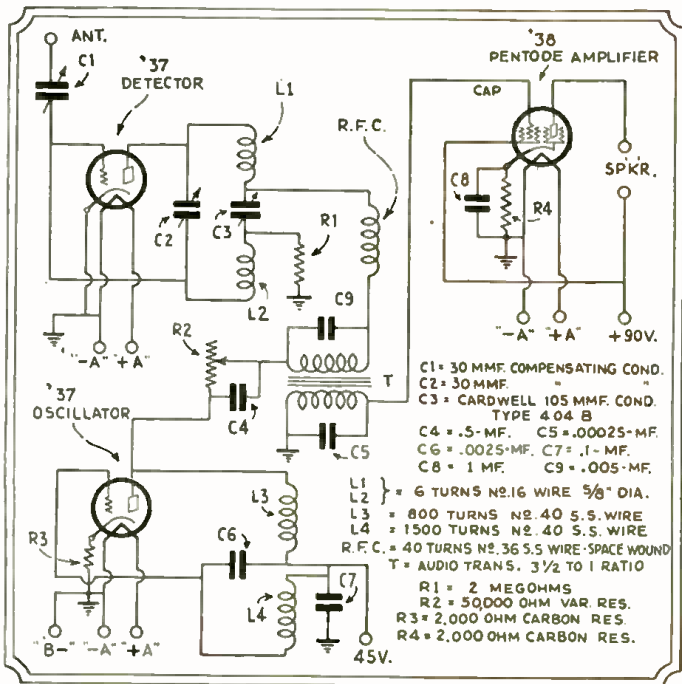

Short Wave Stations of the World

All Schedules Eastern Standard Time: Add 5 Hours for Greenwich Mean Time.

Meters	Kilo-Cycles	Station
4.97-5.35	60,000-56,000	Amateur Telephony and Television
5.83	51,400	W2XBC, New Brunswick, N. J.
6.89	43,500	W9XD, Milwaukee, Wis. Television. Milwaukee Journal.
		W3XAD, Camden, N. J. Television. (Other experimental television permits: 48,500 to 50,300 k.c.; 45,000-46,000 k.c.)
7.05	42,530	Berlin, Germany. Tu. and Thu., 11:30-1:30 p.m. Telefunken Co.
8.67	34,600	W2XBC, New Brunswick, N. J.
9.68	31,000	WBXI, Pittsburgh, Pa.
10.79	27,800	W6XD, Palo Alto Calif. M. R. T. Co.
11.55	25,960	GSSW, Chelmsford, England Experimental.
11.67	25,700	W2XBC, New Brunswick, N. J.
12.48	24,000	W6AQ, San Mateo, Calif. (Several experimental stations are authorized to operate on non-exclusive waves of a series, both above this and down to 4 meters.)
13.92	21,540	WBXK, Pittsburgh, Pa.
14.00	21,420	W2XDJ, Deal, N. J. And other experimental stations.
14.01	21,400	WLO, Lawrence, N. J., transatlantic phone.
14.15	21,130	LSM, Monte Grande, Argentina
14.27	21,020	LSN (Hurlingham), Buenos Aires, Argentina
14.28	21,000	OKI, Podebrady, Czechoslovakia.
14.47	20,710	LSY, Monte Grande, Argentina. Telephony.
14.50	20,680	LSN, Monte Grande, Argentina, after 10:30 p.m. Telephony with Europe.
		LSX, Buenos Aires, Telephony with U. S.
		FSR, Paris-Saigon, phone
14.54	20,620	PMB, Bandoeng, Java. After 4 a.m.
14.62	20,500	W9XF, Chicago, Ill. (WENR)
14.89	20,140	DWG, Nauen, Germany. Tests 10 a.m.-3 p.m.
15.03	19,950	LSG, Monte Grande, Argentina. From 7 a.m. to 1 p.m. Telephony to Paris and Nauen (Berlin)
		DH, Nauen, Germany.
		Press (code) 6:15 a.m.; English: 8:30 a.m. and 11 a.m.; French, daily, 8:30 a.m. Sundays, French.
15.07	19,900	LSG, Monte Grande, Argentina. 8-10 a.m.
15.10	19,850	WMI, Deal, N. J.
15.12	19,830	FTD, Ste. Assise, France.
15.20	19,720	EAQ, Madrid, Spain
15.45	19,400	FRO, FRE, Ste. Assise, France.
15.50	19,350	Nancy, France, 4 to 5 p.m.
15.55	19,300	FTM, Ste. Assise, France. 10 a.m. to noon.
15.58	19,200	DFA, Nauen, Germany.
15.60	19,220	WNC, Deal, N. J.
15.94	18,820	PBE, Bandoeng, Java, 8:10-10:10 a.m.
16.10	18,620	GBJ, Rodmin, England. Telephony with Montreal.
16.11	18,620	GBU, Rugby, England.
16.33	18,370	PMB, Bandoeng, Java.
16.35	18,350	WND, Deal Beach, N. J. Transatlantic telephony.
16.38	18,310	GBS, Rugby, England. Telephony with New York. General Postoffice, London.
		FZS, Saigon, Indo-China. 1 to 3 p.m. Sundays.
16.44	18,240	FRO, FRE, Ste. Assise, France.
16.50	18,170	CGA, Drummondville, Quebec, Canada. Telephony to England.
16.57	18,100	GBK, Rodmin, England.
		W3XA, Chicago, Ill. Testing, mornings.
16.61	18,050	KQJ, Bolinas, Calif.
16.80	17,850	PLF, Bandoeng, Java ("Radio Malabar").
		W2XAO, New Brunswick, N. J.
16.83	17,830	PCV, Kootwijk, Holland. 9:10 a.m. Sat.
16.87	17,780	WBXK, Pittsburgh, Pa.
17.00	17,640	Ship Phones to Shore: WBSN. "Leviathan"; GFWV. "Majestic"; GLSQ. "Olympic"; GDLJ. "Homeric"; GMIQ. "Helgenland"; work on this and higher channels.
17.25	17,380	JIAA, Tokio, Japan.
17.34	17,300	W2XK, Schenectady, N. Y. Tues., Thurs., Sat. 12 to 5 p.m. General Electric Co.
		WBXL, Dayton, Ohio.
		WBXAJ, Oakland, Calif.
		W2XA, Portland, Ore.
		W2XC, Seattle, Wash.
		W2XCU, Ampere, N. J.
		W9XL, Anoka, Minn., and other experimental stations.
17.52	17,110	WOO, Deal, N. J. Transatlantic phone.
		W2XOO, Ocean Gate, N. J. A. T. & T. Co.
17.55	17,080	GBC, Rugby, England.
18.40	16,300	PCL, Kootwijk, Holland. Works with Bandoeng from 7 a.m.
		WLO, Lawrence, N. J.
18.50	16,200	FZS, Saigon, Indo-China.
18.76	16,150	GBX, Rugby, England.
18.88	16,060	NAA, Arlington, Va. Time signals, 11:57 to noon.
18.80	15,950	PLG, Bandoeng, Java. Afternoons.
18.90	15,860	FTK, Ste. Assise, France. Telephony.
18.93	15,760	JIAA, Tokio, Japan. Up to 10 a.m. Beam transmitter.
19.04	15,750	CHI-Hua, Saigon, Indo-China. Telephony.
19.56	15,340	W2XAD, Schenectady, N. Y. Broadcasts 1-3 p.m.; relay to WGY.
19.60	15,300	OXY, Lyngby, Denmark, Experimental.
		Konigsawusterhausen, Germany. After 7 a.m.
		WEXAL, Westminster, Calif.
19.68	15,240	FYA, Pontoise, France. 9:30-11:30 a.m. Service de la Radiodiffusion, 103 Rue de Grenelle, Paris.
19.72	15,210	WBXK (KDKA), Pittsburgh, Pa. Tues., Thurs., Sat., Sun., 8 a.m. to noon.
19.83	15,120	HVJ, Vatican City (Rome, Italy). (See next page.)
		JIAA, Tokio, Japan.
19.99	15,000	CMGKJ, Central Tulnucu, Cuba.
		LSJ, Monte Grande, Argentina.
		VKGA, Perth, West Australia.
20.50	14,620	WMI, Deal, N. J.
		XDA, Mexico City, 2:30-3 p.m.
20.65	14,530	LSA, Buenos Aires, Argentina.

Meters	Kilo-Cycles	Station
20.70	11,180	W8XK, East Pittsburgh, Pa.
		GBW, Rugby, England.
		WNC, Deal, N. J.
20.80	14,420	WPD, Suva, Fiji Islands.
20.95	14,310	G2NM, Sonning-on-Thames, England, Sundays, 1:30 p.m.
20.97-21.26	14,300-14,100	Amateur Telephony.
21.17	11,150	KKZ, Bolinas, Calif.
21.50	13,910	Bucharest, Roumania. 2-5 p.m., Wed., Sat.
22.38	13,400	WMD, Deal Beach, N. J. Transatlantic telephony
22.68	13,220	Ship Phones.
23.00	13,043	TGCA, Guatemala City, Rep. Guatemala. 10 p.m.-midnight.
23.35	12,850	W2XO, Schenectady, N. Y. Antipodal program 9 p.m. Mon. to 3 a.m. Tues. Noon to 5 p.m. on Tues., Thurs. and Sat. General Electric Co.
		W2XCU, Ampere, N. J.
		WOO, Ocean Gate, N. J.
		W9XL, Anoka, Minn., and other experimental relay broadcasters.
23.38	12,820	Rabat, Morocco, Sun., 7:30-9 a.m. Daily 5-7 a.m. Telephony.
23.46	12,780	GBC, Rugby, England.
24.41	12,290	GBU, Rugby, England.
24.46	12,250	FTN, Ste. Assise (Paris), France. Works Buenos Aires, Indo-China and Java. On 9 a.m. to 1 p.m. and other hours.
		GBS, Rugby, England.
		PLM, Bandoeng, Java. 7:45 a.m.
24.63	12,280	Airplane.
24.68	12,150	GBS, Rugby, England. Transatlantic phone to Deal, N. J. (New York).
		FQO, FQE, Ste. Assise, France.
24.80	12,090	Tokio, Japan, 5-8 a.m.
24.89	12,045	NAA, Arlington, Va. Time signals, 11:57 to noon.
		NSS, Annapolis, Md. Time signals, 9:57-10 p.m.

(NOTE: This list is compiled from many sources, all of which are not in agreement, and which show greater or less discrepancies; in view of the fact that most schedules and many wavelengths are still in an experimental stage, and that wavelengths are calculated differently in many schedules, in addition to this, one experimental station may operate on any of several wavelengths which are assigned to a group of stations in common. We shall be glad to receive later and more accurate information from broadcasters and other transmitting organizations, and from listeners who have authentic information as to calls, exact wavelengths and schedules. We cannot undertake to answer readers who inquire as to the identity of unknown stations heard, as that is a matter of guesswork; in addition to this, the harmonics of many local long-wave stations can be heard in a short-wave receiver.—EDITOR.)

Meters	Kilo-Cycles	Station
28.80	10,410	PKK, Kootwijk, Holland.
		KEZ, Bolinas, Calif.
		LSY, Buenos Aires, Argentina.
28.86	10,390	GBX, Rugby, England.
29.30	10,250	T14—Heredia, Costa Rica. (See next page.)
29.54	10,150	DIS, Nauen, Germany. Press (code) daily: 6 p.m.; Spanish: 7 p.m.; English: 7:50 p.m.; German: 2:30 p.m.; English: 5 p.m.; German, Sundays: 6 p.m.; Spanish: 7:50 p.m.; German: 9:30 p.m.; Spanish.
30.15	9,970	GBU, Rugby, England.
30.30	9,890	LSN, Buenos Aires, phone to Europe.
		LSA, Buenos Aires.
		EAQ, Madrid, Spain.
30.64	9,790	GBW, Rugby, England.
30.75	9,750	Aran, France. Tues. and Fri., 3 to 4:15 p.m.
		WNC, Deal, N. J.
30.90	9,700	WMI, Deal, N. J.
30.93	9,600	LQA, Buenos Aires.
31.10	9,610	Monte Grande, Argentina, works Nauen irregularly after 10:30 p.m.
		RVRI, Leningrad, U.S.S.R. (Russia), 2-3 p.m.
31.23	9,600	LGM, Bergen, Norway.
31.28	9,590	VK2ME, Sydney, Australia.
		VK3ME, Melbourne, Australia. (See next page.)
31.30	9,580	W3XAU, Byberry, Pa., relays WCAU daily.
		VPD, Suva, Fiji Islands.
31.33	9,570	WIXAZ, Springfield, Mass. (WBZ), 6 a.m.-10 p.m. daily. Westinghouse Educ. & Mfg. Co.
		SRI, Poznan, Poland. Tues. 1:45-4:45 p.m., Thurs. 1:30-3 p.m.
31.38	9,560	Konigsawusterhausen, Germany. (See next page.)
		NAA, Arlington, Va.
		ZL2XX, Wellington, New Zealand.
31.48	9,530	W2XAF, Schenectady, New York. 5-11 p.m.
31.49	9,520	OXY, Skamleboek, Denmark. 1 p.m. daily; Relays Copenhagen, Sunday 2-3. (Medical ship telephone service, also from Thorshavn, Faroe Islands, and Julianhaab, Greenland.)
31.70	9,460	Radio Club of Buenos Aires, Argentina.
32.00	9,375	EH90C, Berne, Switzerland. 3-5:30 p.m.
32.13	9,330	CGA, Drummondville, Canada.
32.21	9,310	GBC, Rugby, England. Sundays, 2:30-5 p.m.
32.26	9,290	Rabat, Morocco. 3-5 p.m. Sunday, and irregularly weekdays.
32.40	9,250	GBK, Bodmin, England.
32.50	9,230	FL, Paris, France (Eiffel Tower). Time signals 4:56 a.m. and 4:56 p.m.
32.50	9,200	GBS, Rugby, England. Transatlantic phone.
32.26	9,010	GBS, Rugby, England.
33.81	8,872	NPO, Cavite (Manila), Philippine Islands. Time signals 9:55-10 p.m.
		NAA, Arlington, Va. Time signals 9:57-10 p.m. 2:57-3 p.m.
33.95	8,830	Ship Phones.
33.98	8,810	WBSN, S.S. "Leviathan."
34.50	8,690	W2XAC, Schenectady, New York.
34.68	8,650	W2XCU, Ampere, N. J.
		W9XL, Chicago.
34.68	8,650	W3XE, Baltimore, Md. 12:15-1:15 p.m., 10:15-11:15 p.m.
		W2XV, Long Island City, N. Y.
		W2XAG, Dayton, Ohio.
		W4XG, Miami, Fla.
		W3XK, Washington, D. C.
		And other experimental stations.
34.74	8,630	WOO, Deal, N. J.
		W2XDO, Ocean Gate, N. J.
35.00	8,570	RVIS, Khabarovsk, Siberia. 5-7:30 a.m.
		HC2JM, Guayaquil, Ecuador.
35.02	8,550	WOO, Ocean Gate, N. J.
35.50	8,450	PRAG, Porto Alegre, Brazil. 8:30-9:00 a.m.
36.82	8,120	PLW, Bandoeng, Java.
37.02	8,100	EAT, Vienna, Austria. Mon. and Thurs., 5:30 to 7 p.m.
		JIAA, Tokyo, Japan. Tests 5-8 a.m.
37.43	8,015	Airplanes.
37.63	7,980	VK2ME, Sydney, Australia.
37.80	7,930	DOA, Doberitz, Germany. 1 to 3 p.m. Reichspostzentramt, Berlin.
38.00	7,890	VPD, Suva, Fiji Islands.
		JIAA, Tokio, Japan (Testing).
38.30	7,830	POV, Kootwijk, Holland, after 9 a.m.
38.60	7,770	F7F, Ste. Assise, France.
		PKK, Kootwijk, Holland. 9 a.m. to 7 p.m.
39.15	7,660	FTL, Ste. Assise.
39.40	7,610	HKF, Bogota, Colombia. 6-10 a.m.
39.74	7,520	CGE, Calgary, Canada. Testing, Tues., Thu.
39.80	7,530	"El Prado," Riobamba, Ecuador. Thurs., 9-11 p.m.
40.00	7,500	"Radio-Touraine," France.
40.20	7,460	YR, Lyons, France. Daily except Sun., 10:30 to 1:30 a.m.
40.50	7,410	Eberswald, Germany. Mon., Thurs., 1-2 p.m.
40.70	7,370	X26A, Nuevo Laredo, Mexico. 9-10 a.m.; 11 a.m.-noon; 1-2; 4-5; 7-8 p.m. Tests after midnight. I.S.W.C. programs 11 p.m. Wed. A.P. 31.
40.90	7,320	ZTJ, Johannesburg, So. Africa. 9:30 a.m.-2:30 p.m.
41.46	7,230	DOA, Doberitz, Germany.
41.50	7,220	HBD, Zurich, Switzerland. 1st and 3rd Sundays at 7 a.m., 2 p.m.
		Budapest, Hungary. 2:30-3:10 a.m., Tu., Thurs., Sat. Budapest Technical School, M.R.C., Budapest, Műegyetem.
41.67	7,195	VS1AB, Singapore, S. S. Mo. Wed. and Fri., 9:30-11 a.m.
42.00	7,140	HKK, Bogota, Colombia.
42.70	7,020	EAR125, Madrid, Spain. 6-7 p.m.
42.90	6,990	G1AA, Lisbon, Portugal. Fridays, 5-7 p.m.
43.00	6,980	EAR110, Madrid, Spain. Tues. and Sat., 5:30 to 7 p.m.; Fri., 7 to 8 p.m.

(Continued on opposite page)

Short Wave Stations of the World

(Continued from opposite page)

Meters	Kilo-cycles	Stations	Meters	Kilo-cycles	Stations	Meters	Kilo-cycles	Stations
43.60	6.875	F8MC, Casablanca, Morocco. Sun., Tues., Wed., Sat.	49.67	6.010	W9XAG, Chicago, Ill. (WMAQ), PK3AN, Sourabaya, Java. 6-9 a.m.	98.95	3.030	Motala, Sweden. 11:30 a.m.-noon, 4-10 p.m.
43.70	6.860	KEL, Bolinas, Calif.	49.75	6.020	VE9CA, Calgary, Alta., Canada.	101.7	105.3	VE9AR, Saskatoon, Sask., Canada. 3 meters-2,850 to 2,950 kc. Television.
43.80	6.840	CFA, Drummondville, Canada.	49.80	6.020	W9XF, Chicago, Ill.			W1XAV, Boston, Mass. 1-2, 7:30 to 10:30 p.m. daily ex. Sun. Works with W1XAU 10-11 p.m. Shortwave & Television Corp.
44.10	6.753	WND, Deal, N. J.	49.97	6.000	ZL3ZC, Christchurch, New Zealand. 10 p.m. to midnight, Tuesdays, Thursdays and Fridays.			W2XR, Long Island City, N. Y. 4 to 10 p.m. ex. Sundays. Silent 7-7:30 Sat. Radio Pictures, Inc.
44.90	6.675	TGW, Guatemala City, Guatemala. 9-11:30 p.m.			REN, Moscow, Russia. 10 a.m.-5 p.m. English on Sun., Mo., Thur.			W9XR, Chicago, Ill.
44.99	6.660	FBKR, Constantine, Algeria. Mo., Fri., 5 p.m.			VY2BC, Caracas, Venezuela. 7:15-11 p.m. daily ex. Monday.			
45.50	6.560	HKM, Bogota, Colombia. 9-11 p.m.			Eiffel Tower, Paris, France. Testing, 6:30 to 6:15 a.m.; 1:15 to 1:30, 5:15 to 5:45 p.m., around this wave.	105.9	2.833	W6XAN, Los Angeles, Calif.
46.05	6.515	W00, Deal, N. J.			VE9CU, Calgary, Canada.	105.3	109.1	W7XAB, Spokane, Wash.
46.10	6.480	TGW, Guatemala City, Guatemala. 9-11 p.m.	49.97	6.000	Tananarive, Madagascar. Noon to 2 p.m.; 1 to 5 p.m., Sat.			W2XAB, New York City, Columbia Broadcasting System, 2-6, 8-11 p.m., On Sat. and Sunday to 10 p.m. Works with W2XBE on 48.99 meters.
46.60	6.430	RFN, Moscow, U.S.S.R. (Russia). 9 a.m.-1 p.m.	50.23	5.970	HVJ, Vatican City (Rome). (See box below.)			W2XBO, Long Island City, N. Y.
46.70	6.425	W2XCU, Ambere, N. J.	50.80	5.900	HKE, Medellin, Colombia. 8-11 p.m.			W9XAA, Chicago, Ill.
46.70	6.425	W3XL, Bound Brook, N. J. Relays WJZ irregular.	51.22	5.860	XDA, Mexico City, 10-11 p.m.			W9XC, West Lafayette, Ind.
47.00	6.380	HC1DR, Quito, Ecuador. 8-11 p.m.	51.40	5.835	HKD, Barranquilla, Colombia. 7:15-10:30 p.m. Mon., Wed., Sat.; 2-4, 7:45-8:30 p.m. Sunday, Elias J. Pellet.	108.8	2.758	VE9CI, London, Ont., Canada.
		X1F, Mexico City, Mex. 7-9 p.m.; 11 p.m.-1 a.m.	52.50	5.710	VE9CL, Winnipeg, Canada.	110.2	2.722	Aircraft.
47.35	6.335	W10XZ, Airplane Television.	52.72-51.41	5.600	5.710 Aircraft.	112.1	2.938	W9XAF, Sacramento, Calif. State Dept. of Agriculture.
		VE9AP, Drummondville, Canada.	54.02	5.550	WBXJ, Columbus, Ohio.	121.5	2.470	Police and Fire Departments.
		CN8MP, Casablanca, Morocco. Mon. 3-4 p.m., Tues. 7-8 a.m., 3-4 p.m. Relays Rabat.	58.00	5.170	OK1MPT, Prague, Czechoslovakia. 1-3:30 p.m., Tues and Fri.			KGOZ, Cedar Rapids, Ia. - WRDQ, Toledo, Ohio.
47.77	6.280	Strasbourg, France (7)			PMY, Hameln, Java.	122.0	2.458	WPDG, Youngstown, Ohio.
		WVV, Bureau of Standards, Washington, D. C. Tuesdays, 2-4, 10-12 p.m. Standard Frequency Code.	60.26	4.975	GBC, Rugby, England.	122.3	2.452	WRBH, Cleveland, O. - KGPP, Portland, Ore.
47.81	6.270	HKC, Bogota, Colombia. 8:30-11:30 p.m.	60.30	4.975	W2XAV, Long Island City, N. Y.			WPDK, Milwaukee, Wis. - KGPH, Oklahoma City, Okla.
48.00	6.250	HKA, Barranquilla, Colombia. 8-10 p.m. ex. Mo., Wed., Fri.	60.90	4.920	LL, Paris, France.	123.0	2.440	WPDF, Flint, Mich. - WNDA, Miami, Fla. - WPDJ, Philadelphia, Pa.
48.62	6.170	HRB, Tegucigalpa, Honduras. (See box below.)	61.22-62.50	4.800	1,600 Television.			Lansing, Mich.
48.74	6.155	W9XAL, Chicago, Ill. (WMAQ), and Airplanes.	62.50	4.800	W2XV, Long Island City, N. Y.	123.9	2.422	W3XB, Portable.
48.83	6.140	W8XK, East Pittsburgh, Pa. Tues., Thurs., Sat., Sun., 5 p.m. to midnight.	62.56	4.785	W9XAM, Elgin, Ill. (Time signals.)			W3J, Buffalo, N. Y. - KGPE, Kansas City, Mo. (Mo. State).
48.99	6.120	Motala, Sweden. "RadioRadio," 6:30-7 a.m., 11-1:30 p.m. Holidays, 5 a.m. to 5 p.m.			W9XL, Chicago, Ill.	124.2	2.416	WFDI, Columbus, O. - WPDE, Louisville, Kentucky.
		F3ICD, Chi-Hoa (Saigon), Indo-China. 6:30-10:30 a.m.	62.69	4.785	Aircraft.			KGPB, Minneapolis, Minn. - WPDJ, Passaic, N. J.
		W2XE, New York City. Relays WABC.			And other experimental stations.			WPDS, St. Paul, Minn. - WPGA, Tulare, Calif.
		FL, Eiffel Tower, Paris. 5:30-5:45 a.m., 5:45-12:30, 4:15-1:15 p.m.	62.80	4.770	ZL2XX, Wellington, New Zealand.	124.5	2.410	WCK, WRDR, WMO, Detroit (Belle Isle, Grosse Pointe, Highland Park, Mich.)
		Toulouse, France. Sunday 2:30-4 p.m.	63.00	4.760	Radio LL, Paris, France.			WPDW, Washington, D. C.
49.10	6.110	VE9CG, Calgary, Alta., Canada.	63.13	4.750	W00, Ocean Gate, N. J.			KGPD, San Francisco, Calif.
49.15	6.100	W3XAL, Bound Brook, N. J.	63.79	4.700	W1XAB, Portland, Me.			KGPF, Vallejo, Calif. Police Dept.
		VE9CF, Halifax, N. S., Canada. 6-10 p.m., Tu., Thu., Fri.	65.22-66.67	4.500	1,600 - Television.			W3KAG, Baltimore, Md., Police Dept.
49.17	6.095	VE9GW, Bowmanville, Ontario, Canada.	67.65	4.430	DOA, Doberitz, Germany. 6-7 p.m., 2-3 p.m. Mon., Wed., Fri.	125.1	2.398	W9XL, Chicago, Ill. - W2XCU, Ampere, N. J.
49.31	6.680	W9XAA, Chicago, Ill. (W9FL). 6-7 a.m., 7-8 p.m., 9:30-10:15, 11-12 p.m. Int. S.-W. Club program. From 10 p.m. Saturday to 6 a.m. Sunday.	70.00	4.280	OHKZ, Vienna, Austria. Sundays, first 15 minutes of hour from 1 to 7 p.m.			WPDJ, Kokomo, Ind. Police Dept.
49.40	6.070	VE9CS, Vancouver, B. C., Canada. Fridays before 1:30 a.m. Sundays, 2 and 10:30 p.m. Johannesburg, So. Africa. 10:30 a.m.-3:30 p.m.	70.20	4.273	RV15, Khabarovsk, Siberia. (See box below.)	128.0-129.0		Aircraft.
49.46	6.065	SAJ, Motala, Sweden. 6:30-7 a.m., 11 a.m. to 1:30 p.m.			GDLJ, S.S. "Homeric."	130.0	2.306	DDDX, S.S. "Bremen" and "Europa" testing.
49.50	6.060	W8XAL, Cincinnati, Ohio. Relays WLW. 6:30-10 a.m., 1-3 p.m., 6 p.m. to 2 a.m., daily. Sunday after 1 p.m.	71.77-72.98	4.180	1,100 - Aircraft.	136.4	142.9	2 meters-2,100 to 2,200 kc. Television.
49.50	6.060	WQZLO, Nairobi, Kenya, Africa. Monday, Wednesday, Friday, 11 a.m.-2:30 p.m.; Tuesday, Thursday, 11:30 a.m.-2:30 p.m.; Saturday, 11:30 a.m.-3:30 p.m.; Sunday, 11 a.m.-1:30 p.m.; Tuesday, 3 a.m.-1 a.m.; Thursday, 8 a.m.-9 a.m.	71.82	4.175	Ship Phones.			W2XBS, New York, N. Y., 1,200 R.P.M., 60 lines deep, 72 wide, 2-5 p.m., 7-10 p.m. ex. Sundays. National Broadcasting Co.
49.59	6.050	VE9CF, Halifax, N. S., Canada. 11 a.m.-noon, 5-6 p.m. On Wed. 8-9; Sun., 6:30-8:15 p.m.	72.87	4.116	W00, Deal, N. J.			W2XR, Long Island City, N. Y. 48 and 60 line, 5-7 p.m. Radio Pictures, Inc.
		HKD, Barranquilla, Colombia.	74.72	4.105	NAA, Arlington, Va. Time signals, 9:57-10 p.m., 11:57 a.m. to noon.			W3AD, Camden, N. J.
			80.00	3.750	FBKR, Constantine, Tunis, Africa. Mon. and Fri.	81.46-85.66	3.550-3.500	Amateur Telephony.
					13RO (Prato Smeraldo), Rome, Italy.	86.50-86.00	3.490-3.460	Aircraft.
			82.90	3.620	DOA, Doberitz, Germany. (Television.)	92.50	3.256	W9XL, Chicago, Ill.
			81.24	3.560	OZ7RL, Copenhagen, Denmark. Tues. and Fri. after 6 p.m.	92.5-91.9	3.214-3.160	KFR, WJE, City of Seattle, Wash., Light Dept.
					94.00	3.181	KQS, KQT, City of Los Angeles, Calif., Water Dept.	
			95.00	3.156	PKZAG, Samarang, Java.			W2XAP, Jersey City, N. J.
			95.18-97.71	3.112	3.078 - Aircraft.			W2XCR, Jersey City, N. J. 8-5, 6-9 p.m. ex. Sun.
			96.01	3.121	W00, Deal, N. J.			W3XK, Wheaton, Maryland. 10:30 p.m. midnight ex. Sun. Works with W3XJ.
			97.53	3.076	W9XL, Chicago, Ill.			W2XCD, Passaic, N. J. 2-3 p.m. Tu.

(Continued on page 417)

"Star" Short Wave Broadcasting Stations

The following stations are reported regularly by many listeners, and are known to be on the air during the hours stated. You should be able to hear them on your own short-wave receiver. All times E.S.T.

G5SW, Chelmsford, England. 25.53 meters. Monday to Saturday 1:45 p.m. to 7:00 p.m. Signs off with the midnight chimes of Big Ben in London.

HVJ, Vatican City. Daily, 5:00 to 5:15 a.m. on 19.84 meters; 2:00 to 2:15 p.m. on 50.26 meters; Sunday 5:00 to 5:30 a.m. on 50.26 meters.

I2RO, Rome, Italy. Daily on 25.4 meters from 11:00 a.m. to 12:30 p.m., and 3:00 to 5:30 p.m. Woman announcer.

VK2ME, Sydney, Australia. 31.28 meters. Sunday morning from 1:00 to 3:00 a.m.; 5:00 to 9:00 a.m.; and 9:30 to 11:30 a.m.

VK3ME, Melbourne, Australia. 31.28 meters. Wednesday and Saturday, 5:00 to 6:30 a.m.

FYA, Pointoise, France. On 19.68 meters, 9:30 a.m. to 12:30 p.m.; on 25.2 meters, from 1:00 to 3:00 p.m.; and on 25.63 meters from 4:00 to 6:00 p.m.

Konigs-Wusterhausen, Germany. On 31.38 meters, daily from 8:00 a.m. to 7:30 p.m.

HKD, Barranquilla, Colombia. On 50 meters, Monday, Wednesday and Friday, 8:00 to 10:30 p.m.; Sunday, 7:45 to 8:30 p.m.

VE9GW, Bowmanville, Ontario, Canada. 25.4 meters, from 1:00 to 10:00 p.m.

HRB, Tegucigalpa, Honduras. 48.62 meters. Monday, Wednesday, Friday, and Saturday, 5:00 to 6:00 and 9:00 to 12:00 p.m.

T14, Heredia, Costa Rica, Central America. 29.3 meters, Monday and Wednesday, 7:30 to 8:30 p.m.; Thursday and Saturday, 9:00 to 10:00 p.m.

XDA, Mexico City. 25.5 meters. Daily, 3:00 to 4:00 p.m.

F3ICD, Chi-Hoa, French Indo-China. 49.1 meters. Daily from 6:30 to 10:30 a.m.

RV15, Khabarovsk, Siberia. 70.2 meters. Daily, from 3:00 to 9:00 a.m.

Short Wave Question Box

Edited by R. William Tanner

Power-Pack Data

Ed. Lewiston, Los Angeles, Calif., wants:
 (Q.) A circuit of power-pack and values of all parts to be used with the superhet described in Aug.-Sept., 1930, issue, Page 150.
 (A.) The circuit is given herewith. The filter condensers should have a rating of 600 volts. The voltage divider "R" should be preferably a Truvolt 75 watt 15,000 to 25,000 ohm. The output filter choke may be either the field of a 2,500 ohm dynamic speaker or a 30 henry choke.

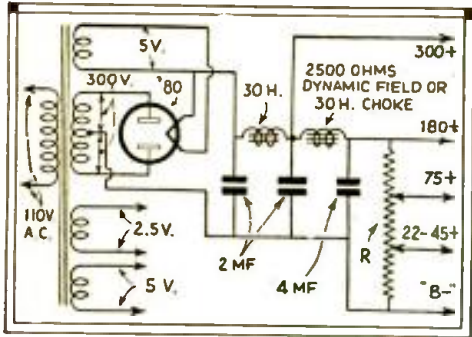

Hook-up of power-pack for S-W super-het.

Power Supply

Henry E. Jacob, Portsmouth, Ohio, asks:
 (Q.) Can you supply me with a circuit for a power supply to be used for both a transmitter and receiver?
 (A.) If you operate both transmitter and receiver from the same power pack, it will cost far more than constructing two separate units since it will necessitate very large chokes and transformer to avoid poor regulation.

Resistor Values

Charles Pollard, Greenland, Mich., wants to know:
 (Q.) The values of the resistors in the article "Hams Own," Page 26 June-July issue.
 (A.) The resistor values are: R, 15 ohms; R1, 10 ohms; R2, .5 to 2 megohms; R3, 100,000 ohms. The by-pass condensers should have capacities of .1 mf.

Night Reception Poor

Geo. G. Symes, Pittsfield, Mass., asks:
 (Q.) I have a very good receiver, but cannot get any results at night in the 20 meter band. Why is this?
 (A.) This is due to the short waves in this vicinity traveling over greater distances in the daytime than at night.

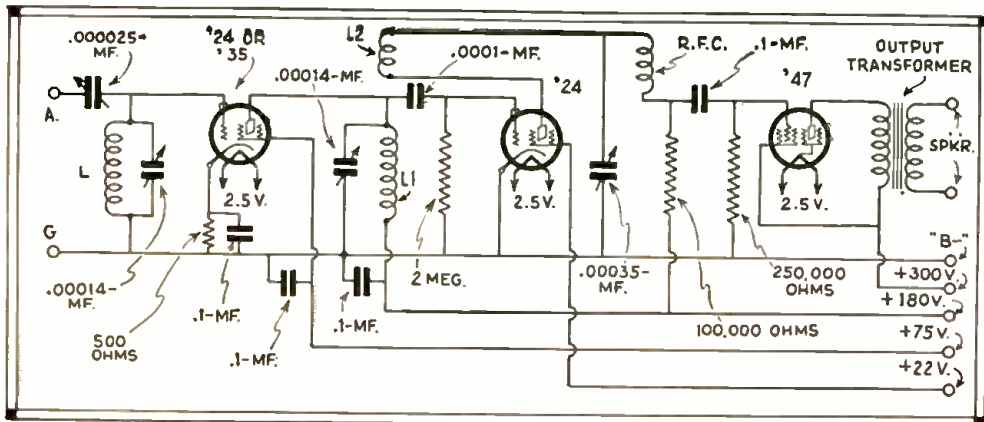

Receiver circuit for tuned R.F. stage, S.G. detector and pentode A.F. output stage.

Space-Charge Detector

James Jackson, Hamilton, Ont., Canada, wants to know:
 (Q.) If I change the present detector in my Pilot A.C. super-Wasp to a space-charge detector, will the sensitivity increase.
 (A.) The sensitivity will increase only slightly. The screen grid connection is the more sensitive of the two.

Peaking I.F. Transformers

Orville Wilmot, San Francisco, Calif., requests:
 (Q.) Data on peaking I.F. transformers to exactly 175 K.C.

(A.) It will be necessary to obtain an accurate oscillator for this work. It is not advisable to build such an oscillator since this will first require calibration. Several excellent calibrated oscillators are available on the market.
 (Q.) Can a 175 K.C. amplifier be employed in a short wave superhet without image frequency interference?
 (A.) Yes, providing there are two or more tuned circuits ahead of the first detector.

"Mike" Amplifier

Joe. McCarver, Shively, Ky., writes:
 (Q.) Will you publish a circuit of a microphone input amplifier for use on an amplifier having a 227 P-P stage and a 250 P-P output stage?
 (A.) This circuit appears in these columns. The plate voltage of 90 to 180 volts may be obtained from the same source as the tubes in the main amplifier.

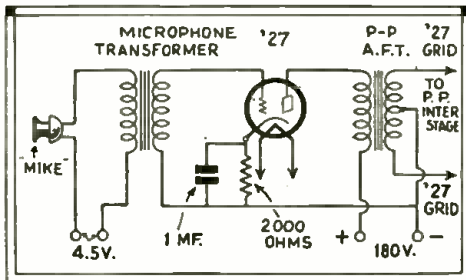

Microphone amplifier circuit.

Europe on a Crystal Detector?!

Verle Hope, Grand Ledge, Mich., wants to know:
 (Q.) If there is any circuit using only a crystal detector which can consistently receive from Europe, South America, etc., without any tubes whatsoever?
 (A.) There is no crystal circuit that can do this nor any other circuit.

Increasing Sensitivity

Geo. Symes, Jr., Pittsfield, Mass., writes as follows:
 (Q.) I have a short wave set using a '32 detector and two '30s as amplifiers. I want to add another tube for increased sensitivity. Will you publish a suitable circuit?
 (A.) The circuit is given in these columns. The R.F. choke in the R.F. grid circuit may be anything with 200 turns or more; however the choke in the plate circuit must be a good short wave type.

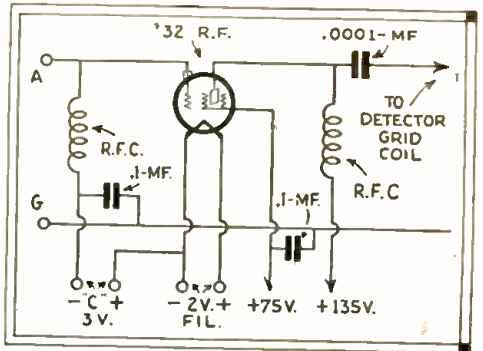

R.F. "booster" circuit to increase sensitivity.

Cure for Howling

Lester Herried, Vermillion, S. D., asks:
 (Q.) For a cure of howling when regeneration is increased to and beyond oscillation.
 (A.) If the first audio stage is transformer coupled, try shunting the secondary with a resistor having a value from 60,000 to 250,000 ohms. If resistance coupling is used, try decreasing the value of the first A.F. grid resistor.

Tube-Base Coil Data

Ralph Wymer, Toledo, Ohio, desires the following information:
 (Q.) In the receiver Page 278, Dec., 1930-Jan., 1931, please give coil data for "tube-base" coils.
 (A.) For the R.F. grid coils L1 wind on 5, 10, 18 and 39 for 20, 40, 80 and television bands respectively. The detector coils have exactly the same windings. The ticklers have 4, 6, 8 and 15 turns for the 20, 40, 80 and television bands respectively. No. 30 D.C.C. wire will do for all windings. Larger wire will not allow the entire winding to be wound on for the television coils.

(Q.) With 425 volts on the plate of a 210 tube what would be the C bias and ohmage of the speaker to be used?
 (A.) The bias would be in the vicinity of 35 volts. A speaker should not be connected directly in the plate circuit of a 210 tube due to the comparatively high current flowing.

A.C. Receiver Circuit

Sam Hendrick, Memphis, Tenn., wants:
 (Q.) A good circuit using a tuned R.F. stage, a screen grid detector and a pentode output stage for A.C. operation.
 (A.) The circuit together with constants is given herewith. The R.F. coil, L, should have 7, 13, 25 for the 20, 40 and 80 meter bands respectively. The grid coils for the detector, L1, will have the same values. The ticklers, L2, will have 5, 7 and 10 turns. S-M type 130P midget forms are advised and the turns spaced over the entire winding space. The ticklers are wound in the slots. Both sets of coils will have to be shielded in separate containers.

A NEW Converter, the EUROPE GETTER

GET EUROPE!

But why stop at Europe? Try for Asia, the Antipodes, or any spot on earth that transmits short waves. It is a positively amazing performer—not "one of those things" but a short-wave converter that thrills you with its big doings. And it works on any set, including a superheterodyne. Sold either in wired form or as a kit.

Everything is of the finest in this converter. In the really beautiful cabinet is the precision chassis. Wave band switching is done from the front panel—15 to 200 meters guaranteed—while the B supply is built in. The tubes are one 224 and two 227. Only two external connections to make. And never any plug-in coil nuisance.

Volume is tremendous, selectivity is razor-like, your broadcast set may be tuned to any frequency in its range, and still the whole world lies before you.

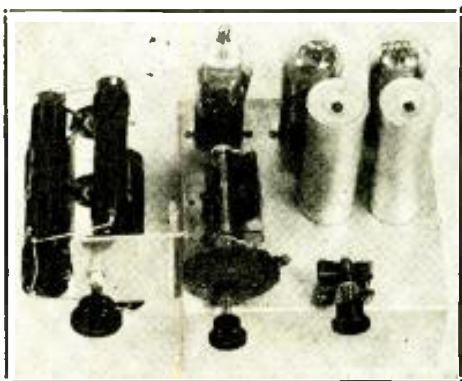

In handsome Walnut Cabinet.

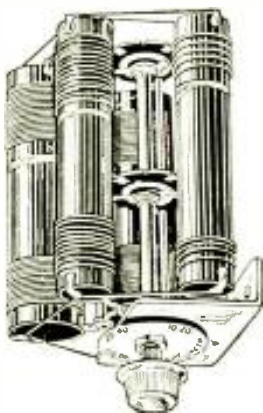

The DX-3W chassis is illustrated above. At right is a clear picture of the coil-switch arrangement. The 227 tubes (rectifier and oscillator) are at right rear on the chassis, the modulator tube at left. The left-hand switch controls wave bands. There are four settings: 10 to 20, 20 to 40, 40 to 80 and 80 to 200 meters. The settings are marked. A long switch is used to pick up each of the four coils at a time—and leads are kept extremely short. The main tuning capacities are a two-gang Hammarlund 0.00014 mfd. condenser. At right is a modulator trimming condenser for perfect resonance regardless of the receiver frequency (intermediate frequency) used. The two grey cylinders are 8 mfd. condensers in the rectifier filter.

The Europe-Getter is a superheterodyne type short-wave converter, works on any set and is sold as kit or wired model on a 5-day money-back guarantee.

"Europe-Getter," short-wave converter, wired model, with tubes: one 224, two 227. For 110v., 50-60 cycles a-c. Cat. ADF @.....	\$32.50
Kit for above, less tubes, Cat. TGP @.....	21.50
(Battery-operated models available. Write for data.)	
Coil-Switch Assembly, 15-200 meters, as used in this converter; bracket included (illustrated). Cat. CSA @.....	7.05
Above assembly with two-gang 0.00011 mfd. Hammarlund condenser. Cat. CSHC @.....	9.87



Cat. PM

Midgets that Lead the World in PERFORMANCE

Our 5-tube standard of excellence is the vari-mu-pentode wired set for broadcast coverage. See testimonials. They tell our story better than we can. Tubes used: two 235, one 224, one 247, one 280. For 110 v., 50-60 cycles a-c. Five-day money-back guarantee. Cat. PM (less tubes) @ \$19. Cat. PMT (with tubes) @ \$23.00.

Testimonials!

Get Foreign Stations on Broadcast Set

We may say in all sincerity that the Polo Midget Radios (Cat. PM) are the finest value for the money we have yet seen in the radio trade. We were able to receive foreign stations here with your set when not even a trace of the carrier wave could be obtained on one of the latest of superheterodynes costing almost twice as much. All our customers are delighted and you may rest assured we shall stick to Polo Midgets.

A. M. PENMAN & COMPANY,
Duckworth Street, St. Johns, Newfoundland.

Mexico City from Pittsburgh

Doubt if I can pay you a higher compliment to your truly marvelous midget set than to order a second one. We had Mexico City distinctly, then WEAP, WJG, WGY, WENR, all clear, with no fading and without an outside aerial.

F. J. WALZ, M.D.,
Forbes Building, Pittsburgh, Pa.

Lauds Tone and DX

Your midget, Cat. PM, is a good coast-to-coast receiver. I tuned in many distant stations. I got Cuba and Mexico at 8 p.m. Saturday. Tone excellent. Very well pleased.

JOHN TANNER,
6027 No. Philip Street, Philadelphia, Pa.

Pennsylvania Gets Pacific Coast

Kindly forward to me another Polo Midget, Cat. PM. Results I am getting from my first set include Chicago in the daytime and KFI and KOA at night, and I am only 60 miles from the Atlantic coast.

CHARLES M. POTTER,
216 George Street, Norristown, Pa.

Junior Model a Knockout, Too

Received your Cat. PJM. It is hot. Have had KFI on several occasions and NEW, Mexico, several times.

CHARLES STRAYER,
Shepherdstown, West Va.

Praises Superior Tone

The PJM set is very satisfactory and is far more selective than any other small set of the radio frequency type I have ever seen. With 125-foot aerial I still have plenty of selectivity and on good nights can bring in WTAM, WLW, KDKA, and have several times had WABC with volume enough to be heard clearly. Also the tone is superior to any set anywhere near it in price.

G. M. RAMSEY,
400 Otis Bldg., Santa Ana, Cal.

"Marvelous" Junior Midget

I have been using your Junior Midget (PJM) for about a month and find it marvelous. It is more sensitive than my big set. I have received, all with plenty of volume, five California stations: KNX, Hollywood; KEL, Los Angeles; KGO, San Francisco; KJL, Los Angeles; KFOX, Long Beach, Cal.; three Mexican stations: XEW, Mexico City; XEB, Mexico City; XED, Reynosa; two Cuban stations: CMCU, Havana; CMCU, Havana; five Texas stations: KFUL, Galveston; WOAL, San Antonio; KPRC, Houston; WBAP, Fort Worth; WFAA, Dallas; one Utah station, KSL, Salt Lake City; two Denver, Colo., stations: KOA, KFEL, besides about 150 stations in the middle and eastern States and Canada. XEW comes in like a local almost any night about 11:30 p.m. Atlantic Standard Time and KNX about 12:30 A. S. T.

DONALD WRIGHT,
1252 Prince St., Truro, Nova Scotia, Can.

Copy of Part Letter from

Mr. Henry Barbas,
52 Mapleton Road,
Grasse Point Farms, Michigan.

"I WISH I COULD LET YOU LISTEN TO THE FINE PERFORMANCE OF THE DX-4. IT SURE IS A GREAT CIRCUIT IF THE RIGHT PARTS ARE USED. THE VERY FIRST STATION I HAVE TUNED IN WAS JIAA, TOKYO, JAPAN. AND THE NEXT KEL BOLINA, CALIFORNIA AT 7 A.M."

SHORT WAVE CONVERTER KIT

Complete parts furnished for building Converter with 15-200 meter range having built-in power supply completely self-operated. Works with Supers as well as T-C-F Sets. Gets Real Results. No plug-in coils. Clear picture diagram makes two hour wiring easy!

\$7.50

Economical Converter Kit and blueprint, less tubes (Cat. ECC).....	\$7.50
Three 227 Tubes (Cat. T-ECC), all three.....	3.15
Blueprint No. 230 (Cat. BP-230).....	.25

Write for Complete Catalog describing several models at attractive prices. This catalog also has reproductions of letters from all parts of the country giving their experiences in reaching stations in all parts of the World.

Our Guarantee!

We guarantee all our products to be absolutely leaders in their class, with unequalled sensitivity, thrilling tone and real selectivity. Buy anything we advertise. Try it for five days. If you find as good a device at twice the price, or believe that performance or workmanship are in any way less than claimed, or for any other reason don't desire to retain the product, we will promptly refund the purchase price. No other manufacturer thinks that much of all his merchandise.

"Five days" means you have five days after actual receipt of merchandise, not including date of receipt thereof nor date of return, in which to take us up on any or all parts of our challenge guarantee.

"Play Safe with Polo!"

Polo Engineering Laboratories

DEPT. SW-6, 125 WEST 45th STREET, NEW YORK CITY, U. S. A.

PORTABLE RECEIVER

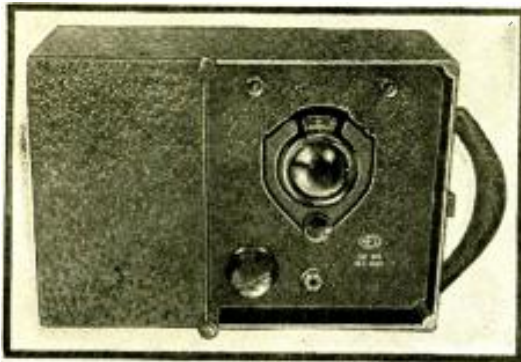

The most compact and efficient receiver available. Capable of Receiving Short Wave Broadcasting and Code Signals from extreme distances. *Ideal for CAMP — PLEASURE CRAFTS — AMATEURS — SHIP OPERATORS — FOREST PATROLS.* LISTEN IN ON THE INTERESTING POLICE DEPT. WORK — WEATHER REPORTS — TIME SIGNALS. APPROXIMATE LIFE OF BATTERIES 1 YEAR. For complete description see article by "Bob" Hertzberg on page 390.



THREE PLUG IN COILS

Covering continuous wave length range from 20 to 100 meters supplied with this Receiver completely wired and tested, \$30.00 (no tubes or batteries included).
 ADDITIONAL SPECIAL COILS, \$1.50 each.
 100 to 200...190 to 370...360 to 500 meters.

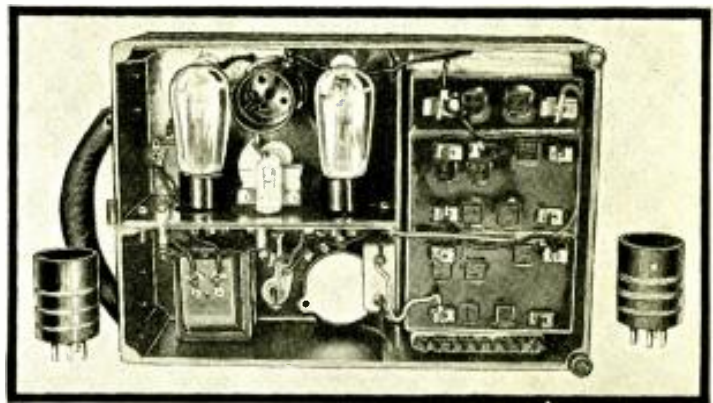

▼
RADIO ENGINEERING LABS., Inc.
 2514 - 41st Avenue, Long Island City, N. Y.

Short Waves To Trap Crooks!

By "BOB" HERTZBERG

(Continued from page 379)

Company. They are tuned and "locked" to the police frequency. The only controls available to the occupants of a car are those for *volume* and *sensitivity*. In the Ford runabouts that form the major part of the "cruiser fleet", the sets are mounted in the rumble seat. In the larger cars, used by gun squads, detective groups and department executives, they are slung under the instrument board. Batteries are used for power supply, and all inter-connections are made by plugs and jacks to facilitate quick removal and replacement of defective units.

Car Aerial Built in Roof

In all cars the aerial is built into the roof or top. In the Ford roadsters sixty feet of rubber covered wire is sewed into the fabric hoods, which are now kept up all the time. In the bigger sedans a large piece of copper screen is employed. If a receiver should fail suddenly, the crew reports immediately to headquarters by telephone. They are directed to a definite corner and await a *service car* that has been dispatched to their aid. This car carries six complete receivers, all tuned up and ready for use, and such accessories as batteries and speakers. The service man simply replaces the defective unit without attempting to make any repairs whatsoever, and releases the car for further patrol. Its crew reports back as soon as possible.

Even if only a tube is blown the whole set comes out, and is returned to the service shop for re-adjustment. Each re-

ceiver is carefully balanced for its own brace of tubes; if a tube is changed the tuning is carefully rechecked. This excellent practice insures maximum performance from the instruments under the rather bad reception conditions that prevail in some parts of Manhattan Island.

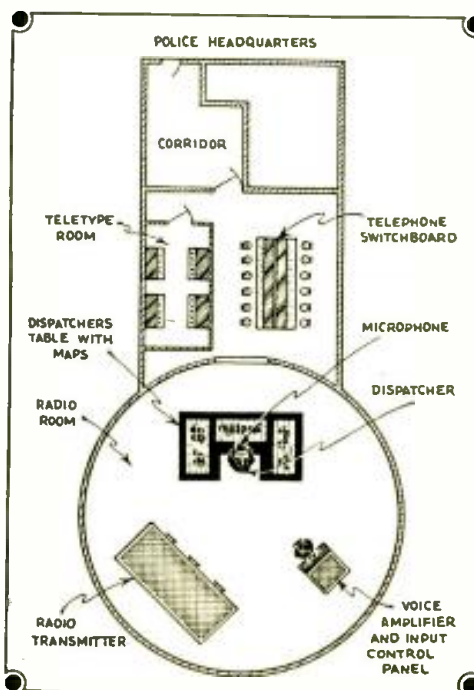

The police S-W "brain-center".

The Center of the Radio Nerve System

An elaborate but flexible system of handling the New York radio alarm system has been worked out by the police. The nerve center is a large "U" shaped table located in the transmitter room at Police Headquarters, only a few feet from the telephone switchboards. All three transmitters are controlled from this point, and no announcements are made from the individual station houses, unless specific permission is granted by the station superintendent. When a telephone call comes in—and thousands of "trouble" messages pour into SPring 3100 during the day—a copy is brought in to the dispatcher sitting in the notch of the big desk, and that man "goes into action"!

Under the glass top of this desk are large maps of the five boroughs of the City of New York, divided off into *patrol areas*. Each car is represented by a brass disc about a half inch in diameter, marked with its number and two colored dots to indicate its class; *i.e.*, two-man runabout, detective sedan, gun squad car, etc. He flips on the transmitter

switch and addresses the microphone, possibly in this fashion:

Form of Dispatch Broadcast

"Car 444. Lenox Avenue and 125th Street. Signal 3. Three men in a blue Cadillac sedan. Hold-up of drug store. Headed north along Lenox Avenue."

The "Signal 3" part is a coded section. It may be interpreted: "Apprehend the driver and occupants. Dangerous characters. Proceed with caution."

If the occurrence is a serious one like this, the dispatcher repeats the alarm through all three stations, so as to warn all other "cruisers." The fleeing car can readily cross any of the numerous bridges around Manhattan, and may be picked up by alert policemen in the other boroughs. If the disturbance is a minor one, say a family argument or a drunk, shattering the peace, the broadcast is "localized" through the nearest station.

After making a call to a specific car, the dispatcher turns over the brass disc bearing its number. The same number appears on the under side, but the dots next to it are bright red. The disc stays in this position until the crew of that car calls back and makes a report, when it is turned over again. If a car is temporarily out of service because of set trouble, a brass ring is slipped over the disc.

By glancing over his big checkerboard the dispatcher thus always knows which cars are busy, which are available, and which are being serviced. If a car directed to the scene of a crime does not report back within a reasonable time other cars are ordered to investigate.

Every half hour the dispatcher broadcasts the correct time. The purpose of these announcements is not so much to check the policemen's watches as it is to assure them that their receivers are working properly. The entire value of the alarm system rests in the speed with which it can get the police to the scenes of crimes, and unreported breakdowns of equipment cannot be tolerated.

Demonstration With U.S. W. Transmitter on 3 Meters

By DR. W. MÖLLER

(Continued from page 389)

and parallel, about 4 inches apart. The length of the wires is about 5 meters (16.4 ft.). At the far end they are fastened by way of the porcelain "eggs", P, to some holding device. Between the porcelain eggs, which serve as insulators, and the holding device there are also inserted spiral springs of steel wire, in order to stretch the wires stiffly.

As the last preparation for our experiment we have to prepare a conducting

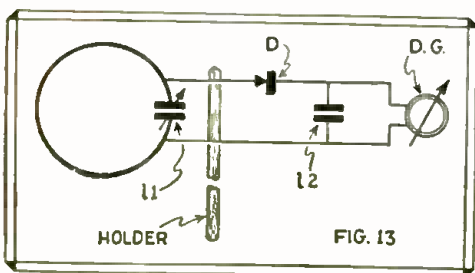

Fig. 13—The "loop" receiver.

ROYAL SHORT WAVE RECEIVER
SCREEN GRID—POWER PENTODE
WORLD WIDE RECEPTION
GUARANTEED



Royal Model RP
LIST PRICE \$25.00

A NEW Super-Sensitive Short Wave Receiver especially designed for the reception of broadcasting and code from all parts of the world, airplane reports, police transmissions, ship conversations, etc. Guaranteed to give better results than others selling for higher prices.

Sturdily constructed on a heavy metal chassis and enclosed in a neat crackle finished cabinet it presents an attractive, efficient appearance. A full vision dial and a combination regeneration.—volume control (with automatic switch) makes tuning remarkably easy. This set tunes from 14 to 200 meters (550 meter coil 75c extra). A special "Ham" model is available with the amateur hands widely spread. (State your choice.) The use of a UX-232 screen-grid detector and a 233 power pentode amplifier gives extreme sensitivity and tremendous volume.

SPECIAL PRICE

\$14.95 Set of Tubes \$2.20
Batteries \$5.45
EXTRA

OTHER MODEL RECEIVERS

These scientifically designed kits contain the highest grade Parts throughout, to obtain maximum results. Every part down to the last nut is included. Complete construction and operating instructions in simple terms included. Easily understood by anyone; will take the guesswork out of home construction. Also supplied AWT (Assembled—Wired—Tested).

All necessary parts of highest quality, including drilled panel and baseboard, and complete instructions. Micro-vernier dial makes close tuning easy. Tunes 14 to 200 meters. (550 Meter coil 75c additional.) Also supplied in special "Ham" type with the 20, 40, and 80 meter bands wholly spread. State choice when ordering.

<p>MODEL R1</p> <p>A sensitive one-tube receiver with a world-wide range! Special refinements make this set superior to any other.</p> <p>AWT\$8.95 Kit 5.95</p>	<p>MODEL R2</p> <p>Same as R1 but with a stage of pentode audio amplification to greatly increase the volume.</p> <p>AWT\$11.25 Kit 6.75</p>	<p>MODEL R3</p> <p>Same as R1 but with two stages of quality audio amplification for loud speaker reception.</p> <p>AWT\$13.20 Kit 8.20</p> <p>Uses power pentode output for tremendous volume.</p>
---	---	--

(Neat bakelite form plug-in coils used instead of large sloppy coils with wire leads easily broken! Best Results!)

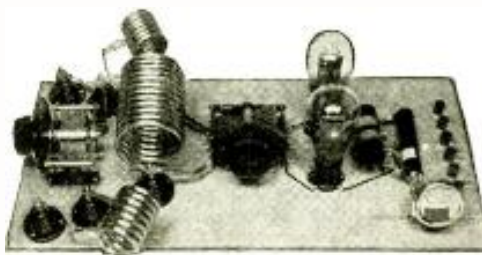

Royal Model TP-P

50c extra. Readrite meter 80c extra. Jewell \$5.00. (Meters not necessary for operation.)

TRANSMITTERS

You can work these transmitters with dry cell tubes with batteries, up through receiver tubes with "B" Eliminators, to a real 210 power tube with one of our high-power transmitting power supplies and obtain amazing results all the way. Heavy copper tubing inductance, good quality variable condensers (add \$1.90 each if you wish (ardwell Condensers), heavy transmitting grid leak, special choke, large porcelain stand-off insulators, resonance indicator, sockets, condensers, dials, hook-up wire, etc., make these transmitters the finest money can buy! Puts out a strong, steady signal that will carry all over the world. Get "On the Air" NOW with a real outfit and experience a new thrill! Inductance supplied for 40 meter band. All models will work on two bands, but maximum results can be obtained only on the band for which it is designed. 80 meter band

<p>MODEL TS</p> <p>An extremely simple transmitter to construct and operate. Only one dial to adjust. Uses the well-known Tuned Plate-Tuned Grid Circuit noted for its stability.</p> <p>AWT\$10.70 Kit 5.75</p>	<p>MODEL TP</p> <p>A standard TP-TG transmitter with more flexibility than the Model TS. Uses two variable condensers.</p> <p>AWT\$12.45 Kit 7.50</p>	<p>MODEL TH</p> <p>Uses the famous Hartley circuit, a favorite with many. Most easily adjusted transmitter.</p> <p>AWT\$14.75 Kit 6.45</p>	<p>MODEL TP²P</p> <p>Push - Pull transmitter. Uses two tubes and has double the output. When two 245 tubes are used with 350 volts the output is as great as a single 210 with 600 volts and far steadier. For UX-245 tubes.</p> <p>AWT\$14.95 Kit 9.45</p>
---	--	---	---

TRANSMITTING POWER SUPPLIES

These well filtered units will give your transmitter a pure DC note with a "Wallop" behind it! Contains heavy duty power transformer, large choke, high voltage condensers, sockets, cord and plug, etc. Delivers both filament and plate voltages. All operate from 110 volt 60 cycle AC house line.

<p>MODEL PA</p> <p>Uses one 250 tube. Output is 300 volts DC at 50 MA. 7 1/2 volts at 2 amp. (easily cut to 5 or 2 1/2 V.)</p> <p>AWT\$6.45 Kit\$4.50</p>	<p>MODEL PB</p> <p>Uses one 280 tube. Output is 350 volts DC at 100 MA. 2 1/2 V. CT—2A, 2 1/2 V. CT—3A.</p> <p>AWT\$10.95 Kit\$7.95 (For Model TP-P 245 Transmitter.)</p>	<p>MODEL PD</p> <p>Uses two 281 tubes. Output is 500 volts DC at 125 MA. 7 1/2 V. VT—2 1/2 A. 2 1/2 V. CT—12A.</p> <p>AWT\$15.95 Kit\$10.95</p>	<p>MODEL PE</p> <p>Uses two 281 tubes. Output is 650 volts DC at 170</p>
--	--	--	---

<p>MA. 7 1/2 V. CT—2 1/2 A.</p> <p>AWT\$17.95 Kit\$12.95 (For Model TP-P 210 Transmitter)</p>	<p>SHORT WAVE ACCESSORIES</p> <p>To insure the maximum results from your receiver and transmitter we advise the use of our SPECIAL SHORT-WAVE TUBES. Every one is tested in a short-wave receiver or transmitter. RCA Licensed. Free replacement for 15 days.</p> <p>UX-201A40c UX-19995c UX-210\$2.95 UX-230, 231, 23785c UX-232, 233, 235, 236, 238\$1.10 UX-24555c UX-247\$1.20 UX-250\$2.05 UX-28060c UX-281\$2.45</p>	<p>Sensitive 2,000 Ohm Headsets\$1.40 Baldwin Loud Speaker Units\$1.45 Phone Plugs25c Antenna Kits95c High Grade Batteries: Dry Cells35c 4 1/2 Volt C35c 2 1/2 Volt C85c 45 Volt Standard B. \$1.40</p> <p>Filament Transformers for AC operation of Transmitters: 2 1/2 Volts at 10 Amps\$2.95 7 1/2 Volts at 4 Amps 2.95</p>
---	---	--

IMMEDIATE DELIVERY All of our Short Wave Apparatus is designed by Government licensed short wave operators with a vast experience in this field.
On any Radio Part
20% DEPOSIT REQUIRED WITH ALL ORDERS—Foreign Orders should contain full remittance plus transportation.

Harrison Radio Company
189 Franklin Street Dept. C-6 New York City

Start Your Career Today

In the world's fastest-growing industry—

You can, if you will, start your career today in the world's healthiest and fastest-growing industry—**RADIO**. The biggest and most talked of building project in the world—**RADIO CITY**—is but an advance sign of the future this industry holds for the man who gets started in it today, while the industry is still young. The first move is up to you. Read this advertisement carefully and then send in the attached coupon. But do it now. Get started.



The three volumes of this library cover the entire field of building, repairing and "trouble-shooting" on modern radio receivers. The Library is up-to-the-minute in every respect and is based on the very latest developments in the design and manufacture of equipment. The rapidly-growing interest in *short-wave reception* is thoroughly covered in a complete section which deals with the construction of this type of apparatus.

Radio Construction Library

INCLUDING CONSTRUCTION
OF SHORT-WAVE AND
TELEVISION RECEIVERS

By JAMES A. MOYER and
JOHN F. WOSTREL

Faculty, University Extension, Massachusetts Department
of Education

Three Volumes — 993 Pages, 6x9
561 Illustrations

VOLUME I: presents the fundamental principles of radio so clearly and simply that anyone of average training will be able to read, understand and apply them. In one chapter alone, it gives actual working drawings and lists of materials for the construction of eight typical sets.

VOLUME II: fully discusses all of the elementary principles of radio construction and repair. An explanation of the necessary steps for "trouble-shooting," repairing, servicing and constructing radio sets successfully. Practical data is also given on antenna systems, battery eliminators, loud speakers, chargers, etc.

VOLUME III: covers the essential principles underlying the operation of vacuum tubes in as non-technical a manner as is consistent with accuracy. It discusses the construction, action, re-activation, testing and use of vacuum tubes; and an interesting section is devoted to remote control of industrial processes; and precision measurements.

EXAMINE these books for 10 days FREE This Library is not only a thorough home-study course, but a handy means of reference for the more experienced radio experimenter, repair man, and radio shop-owner. To these men, as well as to those who desire to advance in the radio profession, this offer of a 10 days' Free Examination is made.

Simply clip, fill in, and mail this coupon

McGRAW-HILL
FREE EXAMINATION COUPON

McGRAW-HILL BOOK COMPANY, INC.
330 West 42nd Street, New York.

Gentlemen: Send me the new RADIO CONSTRUCTION LIBRARY, all charges prepaid, for 10 days' Free Examination. If satisfactory I will send \$1.50 in 10 days and \$2.00 a month until \$7.50 has been paid. If not wanted I will return them at your expense.

Name

Home Address

City and State

Position

Name of Company.....S.W.C. 3-32

bridge for the parallel wires. Basically it is nothing but a wire, in the middle of which a small glow lamp (flashlight bulb) is inserted, according to Fig. 8. The photo, Fig. 9, shows a practical form of this bridge, the wire and lamp being fastened on a strip of hard rubber.

Now we can begin the experiment: The transmitter is set in operation; the coupling between the oscillation circuit and the system of parallel wires, which we regulate by moving the sliding board between the guide strips, is so adjusted that the turns of both systems are from 12 to 15 cm. (4.8 to 6 inches) apart. Then the bridge lying over the wires is slowly pushed in the direction of the arrow. At a distance of about 1.50 meters (4.92 ft.) from the coupling connection the lamp will light up brightly. By this means we have found the first nodal points of the stationary waves forming on the wires. Then we work with a second bridge and push it further toward the end of the parallel wires. At about three meters (9.84 ft.) distance from the coupling connection the little lamp of this bridge also lights up again. By this means the second node of the stationary wave is found. Now if we vary the degree of coupling between the transmitter and the wire system, we can without difficulty so adjust the bridges that they simultaneously light up with the same brightness, so that the points where the simultaneous lighting up of the two lamps occurs stand out sharply.

The desired wavelength then amounts to twice the measured distance between the two bridges. If the measurements and data suggested are adhere to, the measurement by the parallel wire system will show a wavelength between 2.70 and 3 meters.

Experiment 3.—Tuning the antenna. As transmitting antenna we use a dipole, which is to be coupled inductively with the oscillation circuit of the tube. It is therefore provided (see Fig. 10) in the middle with a coupling loop 10 cm. (4 inches) in diameter). Resonance is present between dipole and tube oscillation circuit, when the length of the dipole is equal to half the wavelength. The measuring results of the previous experiment therefore already give the desired indications for adjusting the dipole; so that its length may be varied in a simple manner, it consists of several individual pieces of brass tube, which may be slid one inside another.

The photos, Figs. 11 and 12, show the practical execution and at the same time also the possibility of using the hard rubber block. The resonance between the oscillation circuit of the tube and the dipole antenna can, as is generally the case, be demonstrated and adjusted by an ammeter connected in the node of potential of the antenna. In the case of our dipole antenna this instrument would have to be inserted in the middle of the coupling loop. In our experiment, instead of the antenna ammeter we will use a small glow lamp (flashlight bulb), which is likewise connected in the middle of the coupling loop. With this we have available for tuning the antenna a means which is very simple, cheap, and visible at a great distance for purposes of demonstration.

If in our second experiment we measured the wave length as 3 meters, then our dipole must have the total length of 1.50 meters (1 meter = 3.28 ft.). Reck-

oned from the middle of the coupling coil, each of its halves then measures 75 cm. (.75 meter or 29½ inches).

It is most practical to perform the experiment this way: First we draw out the brass tubes so far that each half of the dipole has a length of 90 cm. (36 inches). With loose coupling of the dipole with the oscillation circuit of the tube we then keep shortening the dipole a few centimeters, until the lighting up of the glow lamp indicates the resonance point. Of course the reductions must be so done so that symmetry with respect to the middle is preserved. Also in this tuning work we must not come too near the dipole, in order that "body capacity" may not disturb the result.

If the right length of dipole is attained and the lamp lights up brightly, then by moving the sliding bridge we can change the degree of coupling, and in this manner give an experimental proof of the general law *that the tuning becomes sharper, the looser the coupling is.*

With the adjustment of the dipole to resonance with the transmitter oscillation circuit, our transmitter is ready for use. It is only necessary to remove the ohmic resistance of the glowing filament from the current path of the dipole. For this purpose the little glow lamp is unscrewed and a short circuit screw or plug is inserted in its holder.

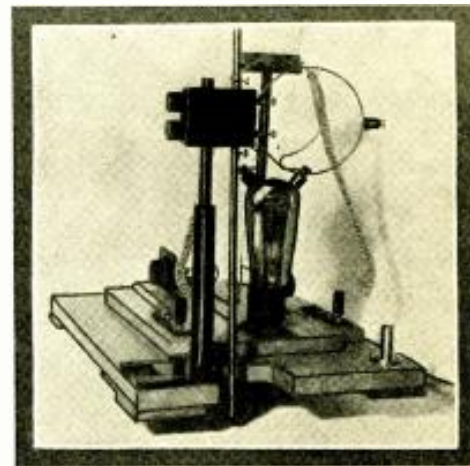

Fig. 12—Transmitter with dipole antenna.

Experiment 4.—Receiving the electric radiation components. The dipole tuned in Experiment 3 radiates an electro-magnetic field. At each point of this field two different vectors occur, the *electric* and the *magnetic* radiation vectors. The electric one oscillates parallel to the transmitting antenna, the magnetic one at right angles to it.

The electric radiation vector produces in every open conductor lying in its direction of oscillation reception alternating currents, which are strongest if the conductor in question is in resonance with the transmission frequency. To demonstrate these facts in as simple and evident an experiment as possible, we use once more a dipole as receiver, this one, however, being without the coupling loop. A small glow lamp in its middle serves as indicator for the reception currents. It is in resonance with the frequency of the radiation field, if its length is equal to that of the transmitting antenna, the latter's coupling loop being imagined to be stretched out straight.

NATIONAL PARTS FOR SHORT WAVE USES

In addition to the parts shown below NATIONAL CO., INC., makes a full line of Transmitting Condensers, Parts and Transformers for Every Kind of Broadcast and Short Wave Circuit, Amplifiers and Power Supplies. Write for our catalog sheets—SWC—4/32.

To be able to tune the receiving dipole in a convenient manner, we also built it out of pieces of brass tube which may be slid one over another. If its length is carefully adjusted, we can obtain from the transmitter (even 5 to 6 meters away) such strong reception currents that the little filament lights up visibly.

Experiment 5.—Reception of the magnetic radiation components. The loop antenna reacts to the magnetic vector of the radiation field. The greatest effect is always attained when its plane of winding is directed to the transmitter. The ultra-short wave of our transmitter occasions that the loop antenna have also unusually small dimensions. The loop consists of a single turn of 10 cm. (4 inches) diameter. It is tuned by a small rotary condenser of 40 mmf. maximum.

Fig. 13 shows the hook-up of our receiver. L1 is the small tuning condenser lying in the loop winding. At both sides of the rotary condenser the detector circuit branches off to which we can fasten a hard rubber rod as holder for the entire apparatus. The detector circuit consists of the detector, D, and the rotary coil galvanometer, DG, parallel to which there is connected a block condenser, L2, of 1,000 cm. capacity.

With a carefully adjusted crystal detector, even at 10 meters (32 ft.), distance from the transmitting dipole we can demonstrate, without difficulty and without placing great demands on the sensitivity of the rotary coil galvanometer, that the reception current strength drops slowly from its maximum, in the case of the loop bearing right on the transmitter, to a very sharply marked minimum, when the loop winding is perpendicular to the direction of bearing of the transmitter, the changes showing as the loop is turned around.

This experiment therefore explains the nature of taking bearings. At the same time it plainly shows the direction to a transmitter is sought not by the *reception maximum* but more practically by the *minimum*, which may be adjusted much more sharply.

With the five experiments described, only a part of the experiments possible
(Continued on page 418)

Short Wave Stations of the World

(Continued from page 411)

- Thur., Sat.
- 142.9 to 150 meters—2,000 to 2,100 kc. Television (Con.)
- W9XAO, Chicago, Ill.
- W9XAA, Chicago, Ill.
- 149.9-174.8—2,000-1,715—Amateur Telephony and Television.
- 175 1,715—W9XAN, Elgin, Ill.
- W6XK, Los Angeles, Calif. And other experimental stations.
- 175.2 1,712—Municipal, Police and Fire.
- KGKM, Beaumont, Texas. — WKDT, Detroit, Mich. — WEY, Boston, Mass.
- WPDB, WPDC, WPDD, Chicago, Ill. — WKDU, Cincinnati, O.
- KSW, Berkeley, Calif. — WKDU, Cincinnati, Ohio.
- KUP, Dallas, Texas. — WMDZ, Indianapolis, Ind.
- KGPC, St. Louis, Mo. — KGOY, San Antonio, Texas.
- KGJX—Pasadena, Calif. (Police Dept.).
- 180.0 1,662—WMP, Framingham, Mass. (State Police).
- WRDS, Lansing, Mich. (State Police).
- 186.6 1,608—W9XAL, Chicago, Ill. (WMAC) and Aircraft Television.
- W2XV, Newark, N. J.
- 187.0 1,604—W2XCU, Wired Radio, Ampere, N. J.
- W2XCD, DeForest Radio Co., Passaic, N. J., 8-10 p.m., synchronized with television broadcasts.
- W1XAU, Boston, Mass.
- W3XJ, Wheaton, Md.
- W9XX, Cartersville, Mo.
- W5XN, Dallas, Texas.
- 187.9 1,596—WCF, New York, N. Y. (Fire Dept.)
- WKOT, Detroit, Mich. (Fire Dept.)
- KGKM, Beaumont, Texas.

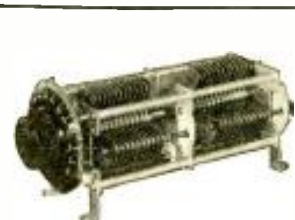

TYPE TMP SPLIT STATOR TYPE TRANSMITTING CONDENSER

Especially suited for 60 MC amateur and experimental work on "High C" and push-pull transmitters. Heavy aluminum straight-line capacity plates, with rounded edges and polished all over. Insulation is CROLITE. Made for 3,000 and 6,000 volts.



STANDARD 4" TYPE N VELVET VERNIER DIAL

Has original and matchless Velvet Vernier mechanism, real vernier scale, reads to 1/10 division. 3 point attachment for easy and accurate mounting. Solid German Silver construction.



VELVET VERNIER DIALS TYPES B and BM

Type B has well known V.V. Variable Ratio of 6-1 to 20-1, bakelite cover; dial is quickly attached without special tools. 5" diam. New Type BM is 3" diam., for use on small receivers and transmitters. Made with fixed ratio only.



DRUM TYPE VELVET-VERNIER PROJECTION DIAL TYPE H

Has same velvet smoothness of all V.V. Dials. Scale is projected in color on to ground glass screen and reads the same from any position, with enlarged figures and scale divisions. Easy to read—no parallax.



SE & ST VARIABLE CONDENSERS for SW Use

A special high-frequency design not a cut-down broadcast job. Has insulated main bearing and constant impedance pig tail. Makes gang tuning possible on short waves. SE has 270° Straight frequency line plates. ST has 180° Equitune plates. Capacities up to 150 mmf.



R.F. TRANSFORMERS AND COIL-FORMS

Available to cover from 33 MC to 150 KC. Forms are moulded R. 39, new low-loss coil material developed by Radio Frequency Laboratories exclusively for us. Blank forms are also available for winding experimental coils with 4, 5 or 6 prong bases.



AUDIO TRANSFORMERS

National Co. makes audio-transformers for all purposes—for receivers, for transmitters. There is a new line of special NATIONAL Transformers for Class B Push-Pull Modulators, and Public Address Systems.



NATIONAL N.C. 5 SHORT-WAVE CONVERTER

MOST POWERFUL MADE
Easily attached to any set in 10 minutes. Works on any set. Has two extra stages of amplification. No plug-in coils. Has own built-in power supply, R.C.A. Licensed. In standard metal cabinet model, and De Luxe Model with solid inlaid mahogany cabinet, shown above.



NEW 6" VERNIER DIAL TYPE NW

Solid German Silver. Has flush vernier, estimates to 1/20 Division. Has 3-point variable ratio. Fully patented construction. For amateur and laboratory uses.



NATIONAL SW-45 THRILL-BOX

The outstanding short wave receiver. Range 9-2000 meters. Very high signal to noise ratio. True single control tuning. Made both in low drain Battery model and in humless A.C. model with special power supply. R.C.A. Licensed.



SHORT WAVE POWER UNIT — TYPE 5880

A separate unit for S.W.A.C. power supply. Power transformer has electrostatic shield between windings, R.F. Filter on Rectifier Tube and special filter section, for humless operation. Separate 2.5 Volt Filament Supply. R.C.A. Licensed.

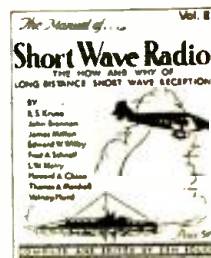

SHORT WAVE MANUAL
61 Pages of latest data on Short-Wave Reception and Receiver Construction by Leading Short-Wave Authorities. Volume 2, now ready, contains ENTIRELY NEW and different material than Volume 1. Price each, Vol. 1 or Vol. 2, 50c. Send today enclosing stamps or coin.



NATIONAL
Precision Radio Products



NATIONAL COMPANY, INC., Sherman, Abbott & Jackson Sts., Malden, Mass.

3-TUBE SUPER-REGENERATIVE PENTODE

5-meter Receiver covers—3.8 to 7.2 meters—for Loudspeaker operation. See this issue of SHORT WAVE CRAFT for description. All Aluminum chassis—full vision dial—new 6-volt tubes—Pentode Output—Super-Regenerative Automatic Filament Control—uses 2-237's and 1-238.

Complete Kit with 3 page booklet on building set.....\$14.50
 All Wired and Tested..... 20.00
3 Guaranteed Tubes—\$3.00 Extra

- | | | | | | | | | | | | | | | | | | | | | | | | | | | |
|------------------------------------|------------------------------------|-----------------------|-------------------------|------------------------|-------------------|-------------------|----------------------|------------------------|---------------------------------------|---|-----------------------------------|--|---------------------------------|-----------------------------------|------------------------|------------------------------------|--------------------------------------|---|-------------------|--------------------------|-------------------------------------|-----------------------------------|--------------------------|--------------------------------------|---|--|
| 2 30 - mmf. Comp. Cond.\$.50 | 1 Cardwell Type 404B Cond.... 1.50 | 1 5-mfd. Cond.... .25 | 1 .00025-mfd. Cond. .25 | 1 .0025-mfd. Cond. .25 | 1 1-mfd.25 | 1 1-mfd.35 | 1 .005-mfd.25 | 1 2-meg. Resistor. .15 | 1 50,000-ohm. Variable Resistor . .50 | 1 United Radio Builders Long Wave Oscillator Coil..... 1.00 | 2 2,000 -ohm. Resistors30 | 1 Detector Grid Coil; 1 Detector Plate Coil.\$.60 | 1 Speaker Filament Jack.... .30 | 3 Wafer Sockets (5 prong).... .30 | 1 5-Prong Socket.. .15 | 1 Crowe Full Vision Dial..... 1.10 | 1 Aluminum Panel (not drilled).. .35 | 1 Chassis (not bent or drilled)75 | 2 Knobs25 | 2 Binding Posts...\$.10 | 1 Pilot Flexible Coupling25 | 1 3½ to 1 Audio Transformer.. .75 | Kit as specified...10.45 | Panel Drilled and Dial Mounted. 1.25 | Chassis Bent with Socket Holes drilled 1.50 | Complete Receiver Built and Tested, \$20.00 |
|------------------------------------|------------------------------------|-----------------------|-------------------------|------------------------|-------------------|-------------------|----------------------|------------------------|---------------------------------------|---|-----------------------------------|--|---------------------------------|-----------------------------------|------------------------|------------------------------------|--------------------------------------|---|-------------------|--------------------------|-------------------------------------|-----------------------------------|--------------------------|--------------------------------------|---|--|

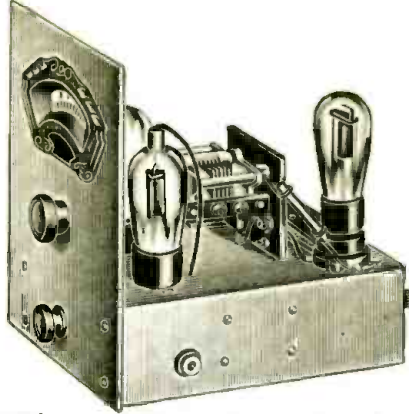

12,500 MILES ON TWO TUBES

See details in Dec.-Jan. and Feb.-March issues of SHORT WAVE CRAFT.
 Complete Kit as described..... \$4.50
 Set complete built and tested..... 9.00
 Uses 2 UX-230 tubes, 2 B Batteries and 2 dry cells.
 Same as above but for world-wide reception on loudspeaker—uses Pentode Output 233 Tube.
 Aluminum Panel—Vernier dial, etc., all wired and tested—covers 15 to 200 meters 16.00
 UX-230 Tubes, 75c each—UX-233, \$1.00 each

SHORT WAVE ADAPTER

Complete kit—as described in SHORT WAVE CRAFT

50 Mmfd. Condensers.....\$.65	100 Mmfd. Condensers..... .75	2-35 Mmf. Compensator..... .60	1-50,000 Potentiometer..... .65	1-00025 Grid Condenser..... .15	1-2 Meg. Grid Leak..... .15	1-1 Mfd. Condenser..... .25	6 Coils, complete..... 1.50	1 Switch25	1 Panel\$.50	1-5x7 Baseboard..... .20	4 Sockets—7x7¼, 15c each..... .60	1 Set Adapter Plug and Cable	1 Vernier Dial..... .50	1 Dial10	Total\$6.75	Your Price..... \$5.95
--------------------------------	-------------------------------	--------------------------------	---------------------------------	---------------------------------	-----------------------------	-----------------------------	-----------------------------	--------------------	---------------------	--------------------------	-----------------------------------	------------------------------	-------------------------	------------------	-------------------	-------------------------------

Free Booklet on Constructing Short Wave Adapter with each order

PARTS FOR "BEST" SHORT WAVE ADAPTER

"Best" Coils complete with switch and escutcheon plate\$7.20	2-Gang 00014 Condenser for use for above 1.60	80-Mmf. Midget Condenser..... .80	6x7x10 Aluminum Shield Box..... 2.75	Parts for New 2 R.F. Pentode S.W. Receiver New "Best" 2 R.F. Coils complete with switch and escutcheon plate.....\$7.50	"Crowe" Full Vision Vernier Dial with knob and plate..... 1.10	UX-230, UX-232, UX-233, each..... .75	UX-236, 237 and 238, each..... 1.00
--	---	-----------------------------------	--------------------------------------	---	--	---------------------------------------	-------------------------------------

Send for our Free AMATEUR Supply Catalog
 WE SPECIALIZE IN OBTAINING COMPLETE KITS FOR TRANSMITTERS AND RECEIVERS AS DESCRIBED IN "SHORT WAVE CRAFT." ALL MERCHANDISE GUARANTEED.
 TERMS: Cash or C.O.D. no deposit required. All prices F.O.B. Irvington, N. J.

Visit Our Store When in Town

UNITED RADIOBUILDERS
 1234-36 • • SPRINGFIELD AVE.
 • • IRVINGTON NEW JERSEY • •

Portable S-W Receiver

By ROBERT "BOB" HERTZBERG

(Continued from page 390)

The plug-in coils are wound on short bakelite tubes fitted over five-prong tube bases. The three windings (primary, secondary and tickler) are placed in grooves, so that they cannot be pulled loose or disturbed. Three coils are supplied with the receivers. These cover tuning ranges from 20 to 29, 28 to 56 and 53 to 98 meters. Larger coils extending the range up to the broadcast band are available.

Because it is self-contained, and requires only the simplest outside connections—for aerial and ground—this portable receiver will appeal to many classes of radio users. It can be employed for monitoring in amateur stations (its perfect shielding prevents excessive pick-up); for interference finding; for time reception by jewelers, astronomers, explorers, etc.; for weather and press reception in commercial stations; for forest patrols and mining expeditions. The batteries give long service, the "B's" being good for nine months or a year and the "A" for a couple of months anyway. A spare "A" battery can be carried in a coat pocket, as it takes no more room than two packages of cigarettes.

A set of this kind should appeal particularly to traveling salesmen who use automobiles,—not for use while on the road, but as a means of amusement at night in a hotel. It takes up no room at all in the car, and is readily gathered up with other baggage. With a length of thin, flexible wire strung out of the window, it will bring in police, amateur and airplane stations by the dozen.

Following are details of the 3 coils:
 Winding form, 2 inches long, 1½ inches in diameter, five-prong (standard UY) base.

Turns on	Primary	Secondary	Tickler
Coil 1 (20-29 meters)	5	3½	6½
Coil 2 (28-56 meters)	9	7½	8½
Coil 3 (53-98 meters)	12	14½	10½

No. 30 double silk covered wire is used on all coils. The primary is separated ¼ inch from the secondary, and the tickler 9/32 inch above the secondary.

Three Meters

(Continued from page 417)

with this transmitter have been presented. In order to indicate at least some other experiments, let it be remarked that the waves radiated out from the transmitting dipole can be reflected by a metal wall, and that they then form stationary waves between the transmitter and the reflecting wall, whose oscillation swells and nodes can likewise be demonstrated very simply.

If the parallel wire system is not stretched in air but in a non-conducting liquid, then the distances between two successive nodes are shortened to an amount characterized by the dielectric constant of this liquid.

Moreover it is possible to set up the transmitting dipole within a parabolic mirror, and thereby collect into a "pencil" the radiation energy emitted by it.

S-M 727 Introduces a New All-Wave Principle By McMURDO SILVER

(Continued from page 402)

quency, or harmonics, which will be somewhat weaker as the harmonics increase.

Second Harmonic—How Used

If the second harmonic of the oscillator is now considered, it will be seen to be 2030 to 3930 kc., from which we must subtract the 465 kc. i.f. to find what signal frequencies it will satisfactorily heterodyne in this set. We find that this range will be 1565 to 3465 kc., or from just below 200 meters to about 87 meters, (there is obviously a gap of 65 kc. between the broadcast band and the 90 to 200 meter band, but actually there is no such gap because the oscillator covers a range sufficiently wider than 550 to 1500 kc. to eliminate it, but the gap is allowed to appear in this explanation as though it existed in order to phrase the explanation in familiar frequency terms. Actually there is an overlap at the 200 meter points, though not as great as some of the really excessive overlaps on the higher frequency bands).

Very little of the fundamental oscillator frequency gets through tube S3, as in all rectifiers, but even if it should, is of little importance, as a careful consideration of all possible aspects, as well as practical tests, will indicate. Likewise the higher harmonics, though stronger, are of no importance, due to the high effective selectivity of the first detector circuit.

Third, Fifth and Ninth Harmonics

The third oscillator harmonic covers the range of 3045 to 5895 kc., from which the i.f. of 465 kc. is subtracted to find the actual signal tuning range, which is 2580 to 5430 kc., or 116 to 55 meters approximately. This third oscillator range, or third harmonic range is utilized by the third first detector tuning coil.

It is apparent from this explanation, how the last two ranges are covered by the fifth and ninth oscillator harmonics generated by the tube S3, and without individually analyzing them, it may be stated that they are from approximately 65 to 32.5 and 34.5 to 17.5 meters, with, in these cases, very large overlaps between bands. (In the last case, the use of the second possible oscillator heterodyne frequency extends the range to 16.5 meters.)

Upon consideration, the whole idea is seen to be almost childishly simple, yet its conception is so new that basic patent applications have been filed on the system.

The circuit of the actual receiver illustrated herewith, deviates from Fig. 1 only to the extent necessary for constructional reasons, such as the method of changing antenna connections from broadcast to short wave bands, etc.

One of the great advantages of the system is that the tuning dial can be divided into five accurately calibrated sections, making the finding of stations quite easy. This calibration is just as accurate as the broadcast band calibration, since it is a mathematical derivative of the latter, and the broadcast calibration being held to plus or minus half a degree (about 3/32" total) the short wave calibrations must be equally accurate. This accuracy is quite sufficient to enable easy hunting in a narrow range for a new station, since once the

dial is set to the range indicated by the selector switch, it is only necessary to adjust the trimmer knob for greatest noise to obtain resonance, when hunting is done by adjusting both knobs simultaneously. Once found, the logging of the oscillator dial, which is quite sharp, while the antenna tuning knob is not nearly so sharp, is absolutely dependable, and stations will always be found at the same dial setting. While the selectivity on all waves is absolute 10 kc., the short wave tuning is delightfully smooth, easy and simple as compared to previous short wave superheterodynes, in some measure accounted for by the very smooth, positive high reduction vernier dial.

10 Tubes Super—With One Dial Tuning

The receiver embodying the development described above is illustrated in Figures 2 and 3 with its circuit diagram in Fig. 4, and its operating curves in Figures 5, 6 and 7. It is a ten tube all A.C. superheterodyne, having but one tuning dial to tune from 16.5 to 550 meters, or 18,000 to 550 kc. Basically the circuit consists of a tuned '24 screen grid first detector, tank-tuned '27 oscillator, '27 harmonic generator tube, two stages of 465 kc. dual tuned, or siamese, '51 vario-mu i.f. amplification, '27 automatic volume control tube, '27 second linear power audio detector, push-pull '47 pentode output stage and '80 rectifier.

Starting at the left of the circuit diagram, Fig. 4, there is seen what appears to be a quite complicated switching arrangement, which, however, is actually very simple. The double-bladed switch serves to connect the '24 first detector grid either to the secondary of the broadcast band antenna transformer, to which is permanently connected the proper section of the gang tuning condenser, or to successively connect it to one of the four short wave antenna coils, and in each case to pick up the short wave tuning condenser, a 200 mf., midget type, which is the auxiliary, or trimmer, tuning adjustment for short waves. The upper switch serves only to disconnect the antenna from the broadcast band primary and to reconnect it to the first detector grid, through a permanently adjusted antenna compensating condenser for short wave operation.

For broadcast band reception the '27 oscillator is directly coupled to the '24 first detector by a small coupling coil in the first detector cathode lead, while for short waves the oscillator is coupled to the proper short wave coils by small coupling coils, all in series, in the '27 harmonic generator's plate circuit. The lower portion of the switch, therefore, serves only to include this oscillator coupling coil in the first detector cathode lead for broadcast band reception, or to cut it out of circuit for short wave reception. Actually, the upper and lower sections of the switch in Fig. 4 are really only S.P.D.T. switches in action, but are physically five-point switches in order that they, being ganged to the main band selector switch, may maintain one set of connections throughout four successive positions of the coil selector switch. It will be noted that the single tuned broadcast band circuit preceding the first detector employs an extremely efficient

WANT TO GET AHEAD IN RADIO?



Experts teach you "why" and "how"

here is the foundation on which to build — study at



NO one can hope to become successful in any branch of radio without the proper training. It was to give this training that America's oldest radio school—RCA Institutes—was founded 22 years ago.

It has graduated thousands of students. Many of them are now high up in the radio industry. Your chance is greater than theirs because of the expansion of the industry. Don't neglect your future. Mail the coupon below and read the news it brings you.

RCA Institutes, in four resident schools in New York, Boston, Philadelphia and Chicago, and in extension courses for home study, specializes in instruction in every practical branch of radio. There are elementary and advanced courses for every type of student. You can study with our modern equipment, under experts at the resident schools—or solve practical radio problems at home with our special home laboratory equipment.

Being a subsidiary of the great Radio Corporation of America, you enjoy the benefits of association with the world's largest radio research laboratory. Thus our courses are kept up to the minute. Yet the tuition cost is moderate.

If this sounds logical to you, why not obtain more information without obligation. Mail the coupon for free catalog. But do it TODAY. If you put it off, you may forget—and miss a great chance.

RCA INSTITUTES, Inc.

A Radio Corporation of America Subsidiary



RCA INSTITUTES, INC.
Dept. CS-4 75 Varick St., N.Y.
Please send me your General Catalog.

I am checking below the phase of radio in which I am interested.

<input type="checkbox"/> Microphone Technique	<input type="checkbox"/> Talking Pictures
<input type="checkbox"/> Broadcast Station or Studio	<input type="checkbox"/> Servicing Home Entertainment Equipment
<input type="checkbox"/> Aviation Radio	<input type="checkbox"/> Television
<input type="checkbox"/> Radio Operating	

Name.....
Address.....
Occupation..... Age.....

TRANSMITTING SETS

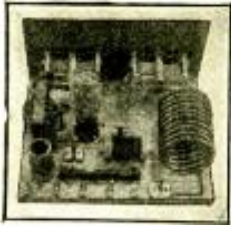

Our modern Kits furnish all necessary parts and hardware to build the transmitters as shown in photo. Full instructions. Will operate AC or DC. Any tubes or batteries or eliminators. Any power from zero to 50 watts. All parts will stand up on high power. (Range: 500 to 1000 miles on receiving tube.) **MODEL A TRANSMITTER:**

\$12.00. Kit, \$6.00. Works in any two Ham Bands without changing coils!!! T. P. T. G. circuit. Single control. Can be used in new phone band at 160 meters. **MODEL B TRANSMITTER:** \$13.00. Kit, \$6.70. Hartley circuit. Phone attachments, \$1 extra. Fil. transformer, \$3.25. Type '45 transmitting tubes, \$1.00. Keys, \$2.25. Nick-elled "Mike," \$5.95.

Delft All Short Wave Wavemeter

This wavemeter is simple to use and saves time in tuning in foreign stations. Look up the wavelength of station wanted, set wavemeter to this wavelength (marked on wavemeter dial), then tune receiver to the wavemeter. Any station easy to find. Not connected to set in any way, just brought near it. Nothing else needed to use it with your set. Tunes 11 to 270 meters so any station can be found. Accurate. Shielded. Calibration remains constant. Numerous other uses: Checking receivers, coil and condenser ranges, transmitters, etc. Absolute necessity to experimenters. Use it to demonstrate your sets. Works with any short-wave regenerative receiver like DELFT, Pilot, S.M., National, etc., etc. Works with battery or electric sets alike. Also works with adapters. Complete Wavemeter with plug-in coils, large accurate calibration chart and FULL INSTRUCTIONS. List Price \$15. Your Special Price Post-paid, \$8.95. Jobbers and dealers see us

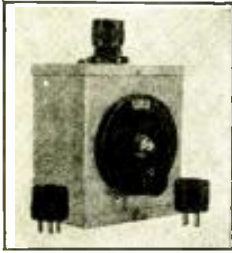

We can also supply a cheaper wavemeter, not quite as accurate. Has plain dial, wooden cabinet. Range 15-120 meters. Complete with chart, \$3.95. **HAM-BAND Wavemeter.** Looks like above meter. 1/4 of 1% accuracy. With calibrated coil for any one Ham band, \$6.95. For each extra band desired, add \$2.00.

TWO-TUBE PORTABLE SET!!



Here's your Set!! Takes up minimum space, easy to move around. All complete as shown. Gives fine loud headset volume on any short wave. Will also get ordinary broadcasts! Light in weight, 1,000 miles on small aerial. Extra slip inside case. Uses 2-volt tubes and PENTODE TUBE (works like 3-tube set!). Size: 9"x18"x7" deep. Complete.

By all means get our low-price catalogue before you buy anything in the short-wave line!! Send few stamps for same. How about ultra-short waves? 2% off for cash in full. Foreign orders cash. If C.O.D., send 15% in bills or stamps, pay rest to postman when delivered.

NEW SHORT WAVE RECEIVERS!!

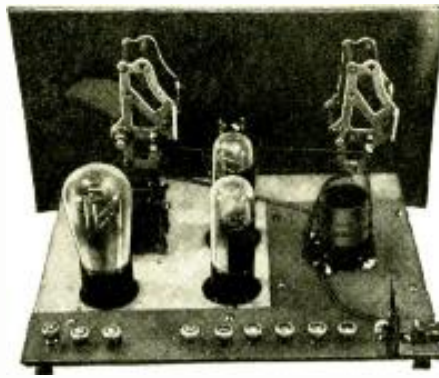

All-Electric or Battery Sets Using Screen-Grid and Pentode Tubes!

PENTODE AND SCREEN-GRID TUBES!! Remember: pentode tubes cost no more but give the volume of two ordinary tubes! Our sets are specially designed to use this fine tube! These sets are BETTER! Anything that goes on at short waves (also ordinary broadcasts) can be picked up with one of these sets, including foreign countries direct! Latest factory metal chassis and all circuit improvements! Get a modern set for less! **ONE TUBE SET COMPLETE (DC)** \$7.90. Tube, \$1.30 extra. 2 dry cells and 1.45-volt B-battery make it complete. Can be used just as it is, as a separate one-tube set, or also as a converter for either an AC or a DC broadcast set. By building a simple oscillator to it, becomes a superb converter of the latest type. Kit of Parts, \$6.45. **ONE TUBE AC SET COMPLETE:** \$9.00. Tube, 90c. AC Kit, \$7.45. **TWO TUBE SET USING PENTODE:** DC Kit, \$6.85. AC Kit, \$8.75. **HIGH-GAIN TWO-TUBE SET:** (AC or DC) Uses screen-grid also pentode tube. \$13.00 Complete. DC Kit, \$8.95. AC Kit, \$10.95. Tubes, \$1.00 extra for DC set, \$2.25 extra for AC set. **HIGH-GAIN THREE-TUBE SET** (Works speaker on better stations) (AC or DC) Uses screen-grid and two pentodes. \$17.00. DC Kit, \$10.00; AC Kit, \$12.00. Tubes, \$6.50 extra for DC set; \$3.75 extra for AC set. **THREE-TUBE KIT** (Uses pentode in last audio only) DC Kit, \$8.35. AC Kit, \$10.35. **FOUR-TUBE UNIVERSAL SHORT-WAVE AND TELEVISION RECEIVER:** (looks exactly like the 3 tube in photo, but is one tube larger). Has Tuned screen-grid R.F. stage, regenerative detector, audio and pentode tube—will work for Television. Works like a 5 tube set! DC Kit, \$15.00. AC Kit, \$18.00. Assembly charge on 4-tube sets is \$8.00. Any of the above AC Kits needs a \$3.25 filament transformer and an inexpensive B-eliminator or power pack to make them complete. You can operate ANY AC SET temporarily on B hats; buy the power pack later. You can use any standard power pack. The DC two and three-tube models need 2 dry cells and 3, 45-volt B battery. Batteries are cheap now. Ordinary loudspeakers, aerial or ground connections can be used. Remember: Our prices may look higher but they are really lower; we believe in showing you exactly what you are getting. All your needs are listed. All sets come complete with a set of plug-in coils, also instructions, of course. Our sets outperform many sets having more tubes! Fine headphones, \$1.95 pr. '27 AC tubes, 90c. (Tested at short waves!)

Send Few Stamps for our Catalogue!!

We manufacture a coil-winding set that makes latest low-loss accurately-spaced short-wave coils. Set includes absolutely everything to make the finest coils money can buy. Includes turn-spacing form, wire forms, and full instructions showing coil and condenser sizes for any short wave. Complete, \$1.49, Postpaid. Short-wave Tuning Condenser (.00015) \$1.35. Regeneration Condenser, \$1.25. We have some slightly used radio parts. Pkg. No. 1, \$1.49, postpaid; pkg. No. 2, \$2.49, postpaid. Latest Natural-Tone Code-Practice Set. Uses '00 tube. 2 Dry cells run it. \$3.85. Tube, \$1.25. 4-prong S.W. tube-base, plug-in coils, set of 3 (15-125 meters) for .0001, .00015 or .00014 condenser; for detector, \$1.50, for R.F. Amplifier use, \$1.25. S.W. hookups FREE with ea. set of coils.

inductance of fairly large size, insuring an excellent ratio of image frequency selectivity, as well as making for a 2 to 1 increase in signal to noise ratio as against the use of a siamese, or dual pre-selector circuit. The short wave antenna circuit is likewise single tuned, and because the tuning range of each of the four short wave antenna circuits is considerably wider than the harmonic range of the oscillator which it is initially intended to utilize, and as this antenna circuit is separately tuned, it is possible to utilize either of the two possible oscillator points for any desired signal, and to develop other combinations of dial settings for a short wave signal (say between 16.5 and 40 meters). If this condition existed in the broadcast band it would be a serious drawback, but on the sparsely populated short wave bands, it permits the choice of an optimum point for any given station at will, and is an appreciable advantage.

Examining Fig. 2, the chassis is seen with the top of the large shield housing the gang condenser and all coils but the oscillator removed. The four short wave coils are clearly visible, as is the gang condenser, 600 kc. oscillator trimmer screw adjustment, and the quite large broadcast antenna coil, with its small over sizes primary visible in its center. The tubes are, right to left, '27 harmonic generator, '27 oscillator, '24 r.f. or first detector, two '51, i.f. tubes, '27 audio detector, '27 A.V.C. tube, two '47 pentodes and '80 rectifier. The tuning meter is seen above the dial, actually centered over the dial, and the i.f. transformers in the three round aluminum cans, their trimmers accessible from below. The power transformer is to the left of the dial, and the audio transformer at the left rear.

The dial is divided into five differently colored sections, corresponding from left to right, to the five successive position of the range selector switch. The four left, or short wave sections are calibrated directly in megacycles, and the right section in kilocycles from 550 to 1500 kc., less the final zero, or from 55 to 150. This greatly facilitates tuning, and reduces "hunting" to setting the dial to the desired point and to simply adjusting the short wave antenna trimmer for greatest noise or loudest signal for any setting of the dial.

In Figs. 5, 6 and 7 appear performance curves on the set. From Fig. 5 the sensitivity is seen to vary from 1.8 to 2.8 microvolts absolute, which is fully adequate for any American location. (Actually these figures have been made low—as low as any set that is ever passed by inspection, practically all being held to less than one microvolt absolute.) Fig. 6 shows a band width of 28 kc., 10,000 times down, which simply means absolute 10 kc. selectivity.

Fig. 7 is quite interesting, indicating the power output in watts plotted logarithmically (as it sounds to the ear) against microvolts input. It will be seen that the power output reaches practically a maximum at 20 microvolts absolute input, and remains constant (at whatever the volume setting may be) from there on up. This represents probably the most perfect job of A.V.C. yet produced, and means that any signal sufficiently above the noise level to be entertainment will come through at the same volume as will a powerful local for any given volume control setting. The fidelity curve

DELFT
Phone: Higate 0748

DELFT RADIO
524-A Fairbanks Avenue
OAKLAND :: CALIFORNIA

SHORT-WAVE AND ULTRA-SHORT-WAVE RADIO SPECIALISTS

UNIVERSAL
HANDI-MIKE LIST \$15.00
2-BUTTON

Maximum volume, minimum hiss, scientifically damped. Truly natural in tone and the most rugged microphone yet devised. No delicate parts to be damaged if dropped, jarred or roughly handled. For announcing, transmitting or home recording. Our Engineering Department is at your service. New catalog covers twelve models from \$5.00 up.

UNIVERSAL MICROPHONE CO., LTD.
424 Warren Lane, Inglewood, Calif., U.S.A.

CLAROSTAT
CONTROL HANDBOOK and CATALOG 1932

FREE!

Write for your copy of the most complete Handbook on every type of a variable resistance—from tiny center taps and volume controls up to heavy motor speed controls. Every Experimenter, Service Man and Engineer should have a copy handy.

CLAROSTAT MFG. CO., Inc.
285 N 6th St. Brooklyn, N. Y.

is flat to a couple of decibels from 40 to 4000 cycles, and then falls off very sharply indeed to insure absolute 10 kc. selectivity and freedom from hiss.

As for results—since an afternoon and evening of playing with the set in Chicago will bring in at least one broadcast station for every dial degree, police stations all over the country, plane to ground conversations, television signals, amateur phones from all over, and all of the principal American, European and Asiatic short wave broadcasters, all without any fading, and with the simplest, sweetest tuning ever found in a short-wave set—what more can be asked?

LEGEND

Model S.M. 127 Shortwave-Broadcast Receiver

- C1-C2—2 Gang Variable Condenser — 365 Mmf. Max. ± 5 Mmf. $0^\circ - 90^\circ \pm 1$ Mmf. $90^\circ - 180^\circ \pm \frac{1}{2}$ of 1%; use with dial scale.
- C3—25 Mmf. Trimmer Condenser.
- C4—200 Mmf. Variable Midget Condenser.
- C5—0.1 Mf. Condenser—Sprague.
- C6—0.1 Mf. Condenser—Sprague.
- C7—0.1 Mf. Condenser—Sprague.
- C8—1.0, .5, .5 Mf. Condenser.
- C9—1.0 Mf. Condenser 150 V. (Dual with C-22).
- C10—.001 Mf. Condenser Mica.
- C11—.001 Mf. Condenser Mica.
- C13—.025 Mf. Condenser—Sprague.
- C14—.006 Mf. 700 V.—Sprague.
- C15—.00015 Mf. Mica.
- C16—Oscillator Trimmer Condenser.
- C17—0.1 Mf. Condenser—Sprague.
- C18—0.1 Mf. Condenser—Sprague.
- C19—0.1 Mf. Condenser—Sprague.
- C20—.0005 Mf. Condenser Mica.
- C22—1.0 Mf. Condenser, 150 V. (See C-9).
- C23—4 Mf. Dry Electrolytic Cond. 450 V.
- C24—8 Mf. Dry Electrolytic Cond. 450 V.
- C25—4 Mf. Dry Electrolytic Cond. 450 V.
- C26—0.1 Mf. Condenser—Sprague.
- L1—197 Broadcast Antenna Coil (550-1,500 K.C.).
- L2—202 Short Wave Antenna Coil (1.56-3.46 megacycles).
- L3—201 Short Wave Antenna Coil (3.51-5.36 megacycles).
- L4—200 Short Wave Antenna Coil (5.54-10.29 megacycles).
- L5—199 Short Wave Antenna Coil (9.6-18.15 megacycles).
- L6—198 Oscillator Coil.
- L7—10145 Choke. (Iron Core Plate Filter.)
- L8-L9—281 R.F. Choke. (1F and 2d Det. C'ts.)
- M—Tuning Meter—15 M.A.
- P1—100,000 Ohm Vol. Control (Com. with A.C. Switch).
- R1—100,000 Ohm Resistor—1 Watt Carbon.
- R2—400 Ohm Resistor—Wire Wound.
- R3—100,000 Ohm Resistor—1 Watt Carbon.
- R4— $\frac{1}{2}$ Megohm Tapered Variable Resistance.
- R5—25,000 Ohm Resistor—1 Watt Carbon.
- R6—300,000 Ohm Resistor—1 Watt Carbon.
- R7—400 Ohm Resistor—Wire Wound.
- R8—60,000 Ohm Resistor—1 Watt Carbon.
- R9—3,500 Ohm Resistor—1 Watt Carbon.
- R10—300,000 Ohm Resistor—1 Watt Carbon.
- R11—1 Megohm Resistor—1 Watt Carbon.
- R12—1 Megohm Resistor—1 Watt Carbon.
- R13—300,000 Ohm Resistor—1 Watt Carbon.
- R14—10,000 Ohm Resistor—1 Watt Carbon.
- R15—10,000 Ohm Resistor—1 Watt Carbon.
- R16—10,000 Ohm Resistor—2 Watt Carbon.
- R17—6,500 Ohm Resistor Ohmite Red Devil—3 Watt.
- R18—229 Ohm Resistor Ohmite Red Devil—2 Watt.
- R19—400 Ohm Resistor—Wire Wound.
- S1—'24 Tube.
- S4 S7-S8-S9—'27 Tubes.
- S5-S6—'47 Tubes.
- S2-S3—'51 Tubes.
- S10—'80 Tube.
- S11—Speaker Socket.
- SW1-SW2—Tandem Change-over Switch.
- SW3—A.C. Switch (Combination with volume control).
- T1—Q-1 I.F. Transformer.
- T2—Q-2 I.F. Transformer.

The COMET "PRO"



Handsome walnut cabinet with "business-like" control panel.

The Hammarlund-Engineered High-Frequency Receiver for Professional Operators



A clean-cut, accessible chassis.

An eight-tube custom-built super-heterodyne, which will do all that the professional operator demands between 14 and 200 meters.

Efficient band-spread tuning system, with special long-wave oscillator for sharp, clean C.W. reception; also simplifies tuning.

Quiet 227 tube output, with phone jack and speaker connections. Connection also for external amplifier.

Super-sensitive; super-selective.

Write for details.

HAMMARLUND Precision PARTS For Short - Wave Construction



ISOLANTITE Short-Wave COIL FORMS. Lowest losses. Maximum sensitivity and selectivity. Non-slipping surface. No drilling. Flat-top handle for marking wave-lengths. Winding surface, 2 1/2" long by 1 1/2" diameter. Four, five and six prongs to fit standard sockets or the new Hammarlund Isolantite Sockets.



ISOLANTITE SOCKETS. Electrical efficiency not affected by temperature or humidity. Top and sides glazed. Perfect contact by reinforced side-gripping rust-proof springs. Four, five and six prongs, with standard mounting centers.

Short-wave TUNING CONDENSER. High capacity; wide range. Soldered brass plates, rugged frame. Double four-point wiping rotor contact. Isolantite insulation. Single and dual models; 20 to 325 mmf. per section.



For Better Radio
Hammarlund
PRECISION
PRODUCTS

Mail the Coupon
H A M M A R L U N D M A N U F A C T U R I N G C O .
424-138 West 33rd St., New York.
Please send details of—New Comet "Pro" Receiver, Short-Wave Coil Forms, Condensers, and Sockets.
Name Address SW-2

Have you read the **EDITORIAL** YET ?

PATENT YOUR IDEAS REGISTER YOUR TRADE-MARK BY
Z. H. POLACHEK
1234 BROADWAY
31st. NEW YORK
DO IT NOW
REG. PATENT ATTORNEY PROF. ENGINEER
WHAT IS YOUR INVENTION?
Send me a simple sketch or model for CONFIDENTIAL ADVICE

Makes Your Radio BEHAVE!

For Every Set

AMPERITE corrects line voltage variations. Improves reception. Installed in 5 minutes. No chassis changes. Write Dept. SW-4 for details.

AMPERITE Corporation
501 BROADWAY, NEW YORK

AMPERITE
Self-Adjusting
LINE VOLTAGE CONTROL

SERVICE MEN
SEND for THIS BOOK
YOU NEED IT
FREE!

1932 PRICE GUIDE

Radio Supplies—Tubes—Sets

Every item you require in your business is in this book, from the finest high grade mike to the smallest screw.

GUARANTEED QUALITY GOODS

Prices Lowest Ever Quoted

Fresh new dependable Merchandise at Bargain Prices!

Leading Manufacturers Lines Complete Send For Your Copy Now!

SAMPLE BUYS FROM THIS BOOK



\$1.98 Replacement Transformer

500V-8Mf Dry Cond.

and Three Thousand Other Bargains

HEADQUARTERS for SERVICE MEN'S SUPPLIES

RADOLEK CO.
601 W. RANDOLPH ST.
CHICAGO, ILL.
USE THIS CONVENIENT COUPON

Radolek Co., 404 Canal Station Chicago, Ill.

Please send me without obligation your Service Man's Supply Book.

Name _____
Address _____
City _____ State _____

"For METER'S Sake" USE LITTELFUSES



Assorted carton of 50 Instrument Littelfuses and 10 mountings. Contains 6 sizes, protecting any meter from the smallest galvanometer to a 0.1 ampere. Saves its cost on one burnout of a good meter. Complete directions on carton and in instructive catalog. I.H. Cash orders post-paid. Price Complete \$8.30

Littelfuses also made in high voltage ranges for transmitter tubes, etc. See your dealer or jobber.

LITTELFUSE LABORATORIES

1768 Wilson Ave., Chicago

GRAPHOMOTOR



The efficient electric phonograph motor—absolutely noiseless—no brushes or automatic switch to cause interference—Speed 1,500 R.P.M. 110 volts—A.C. current—power consumption 20 watts—reduction gears—speed controllable 90 to 70 R.P.M.—finish black enamel—exceptionally low price. Order direct from



MENOMINEE

MICHIGAN

- T3—Q-3 I.F. Transformer.
- T4—10159 Audio Transformer.
- T5—10200 Output Transformer.
- T6—10202 Power Transformer.

Silver-Marshall All-Wave Super-Het. Coil Data

Referring to the I.F. transformers, T-1, 2 and 3 in the diagram, these have 125-mmf. (max.) variable condensers as trimmers across primaries and secondaries as shown. Each I.F. transformer has two coils in an aluminum shield, and each coil consists of 209 turns (10 strands) No. 41 S.S.E. Litz. (Inductance 1 m.h. at 1,000 cycles and resistance 7.6 ohms). The coils are bank-wound and have an internal diameter of 3/4 inch, and each coil is 3/8 inch thick. The 2 coils are spaced about 1 3/8 inches apart and should be not less than 1/4 inch from the aluminum shield can. Both coils are wound in the same direction.

Harmonic Generator Coil Data

1.56 to 3.46 megacycles. Primary L-2—48 3/4 turns. No. 27 enameled wire, space wound. Secondary L-7—18 1/2 turns No. 36 D.S.C. close wound.

3.51 to 6.36 mc. primary L-3—23 3/4 turns No. 21 enameled wire, space wound. Secondary L-8—12 1/2 turns No. 36 D.S.C. close wound (these coils so far specified wound on 1 1/4 inch outside diameter bakelite tubing).

5.54 to 10.29 mc. primary L-4—16 3/4 turns No. 19 enameled wire, space wound; secondary L-9—12 1/2 turns No. 36 D.S.C. close wound.

9.6 to 18.15 mc. primary L-5—6 3/4 turns. No. 17 enameled wire, space wound. Secondary L-10—10 1/2 turns No. 36 D.S.C. close wound.

Broadcast Coil Data

Primary 450 turns No. 34 D.C.C. wire, bunch wound .5 inch in length on a form 2 inches in diameter. Secondary 83 turns No. 24 enameled wire wound on the same tube, which is 3 3/8 inches long.

Oscillator Coil: L-6, L-11—11 turns No. 36 enameled wire, close wound.

L-12—30 turns No. 36 enameled wire, close wound.

L-13—84 turns No. 28 enameled wire, wound 6S turns per inch.

Coils L-11, 12 and 13 are wound on 1 1/4 inch outside diameter tube; these three coils being placed in a row with 1/2 inch space between coils, the order being L-11, L-13, L-12.

Over one end of L-13, near coil L-11, is wound coil L-14, comprising 43 turns No. 36 enameled wire, close wound, on a tube 1 1/2 inches outside diameter.

(To be concluded in next issue.)

A Crack German Short Wave Station

By DR. L. ROHDE

(Continued from page 391)

The first stage produces a constant frequency by a piezo-oscillator, which is either doubled or directly amplified by the second stage. Here it is well to use a screen-grid tube, which prevents feedback action on the first stage. In this manner one obtains a very constant tone for telegraphy.

The third stage operates as push-pull amplifier. By exact symmetrical construction one can very easily neutralize this stage. A high degree of efficiency is obtained; also such a stage lends itself well to correct modulation.

The fourth stage, like the third, is used for amplification. In the arrangement shown one can obtain a very high degree of amplification without feedback action.

Everything else is clear from the drawing.

The current distribution for the entire station is made from a switchboard, as shown by Fig. 3.

—building, testing and repairing radio sets



The three volumes of this library cover the entire field of building, repairing and "trouble-shooting" on modern radio receivers. The Library is up-to-the-minute in every respect and is based on the very latest developments in the design and manufacture of equipment. The rapidly-growing interest in short-wave reception and television is thoroughly covered in a complete section which deals with the construction of this type of apparatus.

Radio Construction Library

(1931 Edition)

By JAMES A. MOYER and JOHN F. WOSTREL

Three Volumes—993 Pages, 6x9 561 Illustrations

VOLUME I: presents the fundamental principles of radio so clearly and simply that anyone of average training will be able to read, understand and apply them. In one chapter alone, it gives actual working drawings and lists of materials for the construction of seven typical sets.

VOLUME II: fully discusses all of the elementary principles of radio construction and repair. An explanation of the necessary steps for "trouble-shooting," repairing, servicing and constructing radio sets successfully. Practical data is also given on antenna systems, battery eliminators, loud speakers, chargers, etc.

VOLUME III: covers the essential principles underlying the operation of vacuum tubes in as non-technical a manner as is consistent with accuracy. It discusses the construction, action, re-activation, testing and use of vacuum tubes; and an interesting section is devoted to remote control of industrial processes; and precision measurements.

EXAMINE these books for 10 days FREE This Library is not only a thorough home-study course, but a handy means of reference for the more experienced radio experimenter, repair man, and radio shop-owner. To these men, as well as to those who desire to advance in the radio profession, this offer of a 10 days' Free Examination is made.

Simply clip, fill in, and mail this coupon

McGraw-Hill FREE EXAMINATION COUPON

McGraw-Hill Book Company, Inc. 370 Seventh Avenue, New York.

Gentlemen: Send me the new 1931 RADIO CONSTRUCTION LIBRARY, all charges prepaid, for 10 days' Free Examination. If satisfactory I will send \$1.50 in 10 days and \$2.00 a month until \$7.50 has been paid. If not wanted I will return them at your expense.

Name _____
Home Address _____
City and State _____
Position _____
Name of Company _____ SWG* 3-32
(WRITE PLAINLY AND FILL IN ALL LINES)

MIGHTY-ROLAND RADIO SET

COMPLETE WITH 5 EVEREADY 4-PILLAR TUBES

Special Introductory Price

\$16.95



5 Tubes—Multi-Mu—Pentode—High Gain—Extraordinary Selectivity—Shielded Chassis—Laboratory Tested for Tone and Sensitivity—Also Powerful Dynamic Speaker—Works Both on Indoor and Outdoor Antenna—Wavelength 195 to 550 Meters.

Also 2-Tube Short Wave Kit using Hamerlund Condensers—Wavelength 15 to 250 Meters—Complete less Tubes and Cabinet, \$10.00.

ROLAND RADIO COMPANY

Dept. S.W.C.

27-35 Hooper St. Brooklyn, N. Y.

G.E. PHONOGRAPH MOTOR



Synchronous 110 Volt, 60 Cycle, 80 R.P.M. Motor

Can be installed in place of old fashioned hand winding spring motors. Also

many other uses. These G. E. motors are all brand new in original factory cartons, fully guaranteed \$12.00 value only \$3.95, including 12 inch turntable. Shipped prepaid. Manufacturers and dealers write for Special Quantity Prices.

NATIONAL JOBBING & EXPORT CO.
109 W. Lake St. Dept. 214. Chicago

Only **\$3.95** 12c VALUE

DEALERS—AGENTS WANTED

EVERYWHERE to Handle the Fastest Selling Radio Attachment on the Market Today

THE POLICE LOWWAVE CONVERTER

A new invention that is easily attached to any radio—by means of which anyone can tune in, at any time on local police broadcasting and get such thrilling—exciting—and often sensational—items as headquarters puts on the air for Radio-Police squads. Simple instructions are furnished.

SELLS FOR ONLY \$3.00

Send \$1.79 for sample, no stamps. Or if you wish, send 10c in stamps for C.O.D. order and pay Postman the balance of \$1.69.

POLICE LOWWAVE LABORATORIES
1460 Huron St. Dept. 2 Toledo, Ohio



What Time and Season to Listen for Certain Waves

By M. H. GERNSBACK

(Continued from page 407)

spring and fall there is a transition period. In the fall, good reception periods gradually change from evening to afternoon hours, and then to morning hours in midwinter, as mentioned above. In the spring the process is just opposite that of fall.

For reception from the west the 25 meter band is good from 6 P. M. till about 3 A. M. in midsummer for distances up to 5,000 miles; for distances up to 10,000 miles it is good from about 1 A. M. till 9 A. M. E. S. T. In the wintertime for western stations up to 5,000 miles reception is good from 2 P. M. till around 9 P. M. E. S. T. Over 5,000 miles reception is liable to vary, due to the fact that signals may reach the receiver either from the east or west.

Reception from the south on these waves in summer time is good from 8 P. M. till about 1 A. M. and from 6 A. M. till 8 A. M. In winter they may be useful during daylight hours, but they are not of much use between 10:30 P. M. and 7 or 8 A. M.

Wavelengths between 29 and 35 meters will be taken up now. Reception from the east 3,000 miles and over in summer time is possible between 5 P. M. and 2 A. M. E. S. T., or when darkness prevails over the whole distance or nearly so. In winter time reception is possible from about 2 P. M. till 7 P. M.; seldom later than this time. On occasion reception may be had around 7 A. M. from the east (up to 5,000 miles).

Reception from the west for distances of 3,000 miles in summer time is possible from 10 P. M. till 8 A. M. For distances greater than this, reception is possible from about 1 A. M. till 8 or 9 A. M., or when darkness is nearly (or totally) complete across the whole distance. In winter time for distances of 3,000 miles reception is possible from 3 P. M. till about midnight. For greater distances, that is, from 8,000 to 10,000 miles, reception may be good from 4 A. M. till about 11 A. M.

Variations may be noted here because the signals may reach the receiver either from the east or west. For reception from the south the best hours in summer time are from 9 P. M. till dawn. In winter time from 6 P. M. till 11 P. M. and from 6 A. M. till about 9 A. M. The morning period is not as good, in general, as the evening period.

The band between 35 and 42 meters is quite similar in most respects to the 30-35 meter band. The only difference being that it is necessary to have almost total darkness at both transmitter and receiver for good reception in summer. This band is better for winter reception than the 30-35 meter band.

The last group of waves that we shall consider is that from 42-50 meters. These waves are almost entirely useless for distances over 3,000 miles in summer time, if there is appreciable daylight over any part of the signal transmission route. In winter time, however, good results may be had if one end of the system is in broad daylight. Thus European stations operating around 49 meters are occasionally heard here at 3 or 4 P. M. on a winter's day. Best reception is had, of course, at all times when total darkness prevails over the whole circuit.

PRESTON OHMMETER



A new vacuum tube operated ohmmeter using one 227 tube. Works right off the A. C. Line.

Has three scales, testing resistors from 0 - 10,000 ohms. 10M - 100M and 100M to a megohm.

All A. C. operated and checks up to a megohm.

Complete in fabrakoid covered wood box, with cover, lock, and carrying handle.

List price \$15.00. Special price to experimenters \$9.25.

BEEDE ELECTRICAL INSTRUM. CORP.

Penacook, N. H.

WIRELESS or WIRE TELEGRAPHY

Everything Needed to Acquire Either or Both Codes

Code Transmitter
10 Rolls of Tape
(2,000 ft. mtr.)
Complete Book of

(Both Codes)
Extra Tapes
Write for Details

Instruction.

INSTRUCTOGRAPH CO.,
912 Lakeside Place

Dept. SW-6
Chicago, Ill.



TELEVISION

As pioneers in experimental and development work in every branch of the television field, including lens-disc projection equipment, cathode ray apparatus, ultra short-wave receivers, etc., many of our products are now available to the public at moderate cost.

Many new products in process will be marketed as rapidly as developed.

Literature on request.

TELEVISION MFG. COMPANY OF AMERICA, Inc.

Sales Office: 5 Union Square, New York
FACTORY: 73 LIBERTY AVE., B'KLYN, N. Y.

What Are You Doing to Prepare Yourself for the Future?

Have you definitely decided upon your career or are you still groping in the dark?

Why Not Go Into a Growing Field Where There Are Unlimited Opportunities for Advancement?

Radio and its numerous branches are virgin fields and the men in the industry have splendid opportunities of getting ahead.

Have a Training That You Can Fall Back Upon and Insure Your Future!

Don't be caught in an economic upheaval. Be prepared with another vocation—you have two chances of getting a position.

We Teach You Everything You Need to Know to Qualify Yourself as an Expert.

Our system has made specialists of men of ordinary school education.

The Price of This Training is a Small Percentage of What It Would Cost Otherwise to Obtain.

After you read our pamphlet SW-8 you will learn that our system will cost you only one-third of what you expected to pay.



Teleplex Company 76 Cortlandt Street, New York, N. Y. SW-8

I am very much interested in laying the foundation for a better future and would like you to send me your pamphlet which explains all. I am not obligated in any way.

Name

Address

City..... State.....

Solving the B.C. Problem

By THOS. A. MARSHALL

(Continued from page 399)

cast spectrum. There are a number of short wave converters on the market to meet the increasing demand for receiving certain short wave stations throughout the world which broadcast programs. These converters would not be suitable for reception of extremely short wave lengths, due to the limited range of wave lengths which they cover.

The circuit as shown in Fig. 5 is suitable, due to the fact that it will cover all the present short wave lengths which are used for broadcast purposes, as well as the ultra short wave lengths. The converter is employed in conjunction with a broadcast receiver by connecting the output of this unit to the input of the broadcast receiver. The latter unit is tuned to some frequency around 550 meters. A short wave station is then tuned in on the converter, which actually converts the low wave to a wavelength of 550 meters where it is amplified and detected.

In actual operation, it has been found that the results obtained from this converter, operated in conjunction with a good broadcast receiver, gave the best of results. The selectivity is extremely satisfactory, and the problem of image frequency is reduced to a negligible value. The converter may also be employed with a super-heterodyne receiver by what is termed double super-heterodyning.

In conclusion, the writer wishes to emphasize the fact that there are still too many stations in some localities, and not enough in others; too much interference to distant stations, and not enough "cleared" channels. By employing a new band for local broadcast, the present conditions will be corrected, and the air over every spot in the country will be full of wonderful radio programs of useful entertainment available to every one who has the "price of a set of some sort to hear the big show."

Coil Data

Band in meters	Coil No.	L	L1	L2	L8	L7	Diameter of coil in Inches
80	1	6	22	21	20	6	2
40	2	6	14	14	13	6	2
30	3	6	8	8	7	4	2
20	4	5	6	6	5 1/2	4	2
15	5	5	3 1/2	3 1/2	3	3 1/2	2
11	6	4 1/2	4	4	4	4	1
9	7	4	3 1/2	3	3	4	1
7	8	4	2 1/2	2 1/2	2	4	3/4
5	9	3	2	2	2	4	1/2

For coils numbers 8 and 9 space tickler coil by trial until the desired frequency is obtained.

Coils 6 to 9 inclusive are wound with No. 22 DSC wire without spacing of turns.

L, L1, L2 and L8 for coils Nos. 1 to 5 inclusive are wound 20 turns to the inch with No. 22 enamel covered wire.

L7 for coils Nos. 1 to 5 inclusive are wound with No. 28 enamel covered wire. Tickler and grid coils for coils Nos. 1 to 5 are spaced 1/2 inch.

L7 is center-tapped for plate voltage feed and for output of converter to the broadcast receiver.

The detector is the frequency changer, and functions as an autodyne detector circuit. Due to its sensitivity and ease of operation, this method of frequency changing is employed rather than an additional oscillator stage, which forms an essential part of every super-heterodyne receiver.



Short-Wave Coil Assembly Eliminates Plug-in Coils

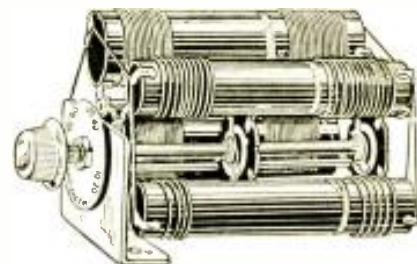

An assembly of four short-wave coils and a low capacity switch eliminating the inconvenience of plug-in coils. Just a turn of the switch enables covering of entire short-wave bands from 10 to 200 meters.

This coil and switch assembly can be easily wired into a super-heterodyne Short Wave Converter circuit; also a modified model is available for use with two tuned R.F. stages, 5 switches controlled by a single knob, switching the coils in both R.F. stages.

Complete wiring diagrams and instructions for building Short Wave Converters or 2 R.F. Short Wave Receivers furnished with each assembly.



We manufacture anti-capacity band changing switches for use with any short wave coils. Furnished with knob and escutcheon plate showing wave length from 10 to 200 meters. List price \$4.00. Write for Prices.

Send for Circular SW-4 and get full information.

Best Manufacturing Company

1200 Grove Street

Irvington, N. J.

A Real Universal Meter

that is creating widespread interest

COMBINATION MULTI-RANGE

Voltmeter and Milliammeter, A.C. and D.C.

employing the new Weston A.C. and D.C. Type 301 Universal Meter and

SHALLCROSS Super Akra-Ohm



RESISTORS

The voltage range is from 5 to 1000 volts, 1000 ohms per volt and the current range is from 1 to 500 Milliamperes A.C. and D.C.

A complete diagram and full information on the construction of this circuit are contained in our Bulletin 150-X, which also contains very useful information on the application of Akra-Ohm Resistors to multi-range voltmeters, ohm meters, etc.

This circuit is fully described in an article on page 769 of the March issue of RADIO NEWS.

Our new Bulletin 150-X will be sent upon receipt of 4 cents in stamps.



When To Listen In

By "BOB" HERTZBERG

G5SW Increases Schedule

SHORT-WAVE fans along the Atlantic seaboard will be glad to learn that G5SW, the famous short-wave relay broadcasting station of the British Broadcasting Corporation, is now on the air on Saturdays in addition to the first five days of the week. The new schedule will afford many listeners the opportunity to tune in this station for the first time, as many do not work Saturday and do most of their daylight listening on this day. The B. B. C. programs are broadcast between 7:30 and 8:30 a. m. and also between 1:45 and 7:00 p. m., Eastern Standard Time. For several years G5SW has been noted for its closing signature, the midnight bells of Big Ben, in London.

Station G5SW, which is located in Chelmsford, England, transmits on 11.750 kilocycles or 25.53 meters. At this time of the year best reception is obtained during the *morning period*, although many listeners are able to bring in intelligible signals during the afternoon also.

Springfield Active

Operated simultaneously with WBZ-WBZA on the regular broadcast band, short-wave station W1XAZ is heard far and wide on 31.35 meters, or 9,570 kilocycles. It is now using a power of 10,000 watts, and is on the air daily from 7:30 a. m. to midnight, Eastern Standard Time. Reports of reception are acknowledged.

The Hawaiian Phones

"I have just received my February-March issue of *SHORT WAVE CRAFT* and in looking through it I read on page 362 about the *Hawaiian Island phone*, which has lately been put into service.

"This phone service was heard by me from the day it started testing, and I listen to it every day, both the Hawaiian end and the New York end. For your information the Hawaiian dope is as follows:

"The call letters are KKP, the frequency 16,030 kilocycles, and the power of the transmitter is 10,000 watts. Except for announcements they use privacy (*that is, the conversations are scrambled—Editor*). Also here on the Pacific Coast the transmitter of the R.C.A. Communications Department, call letters W6XI, 31.64 meters, is used to relay programs for the N.B.C. Station W6XI is located at Bolinas, California, and transmits to Koko Head, Hawaii, KR0, 5,845 kilocycles. I hope this information may be of some value to other listeners."

KARL J. NEWMAN,
614 38th Avenue,
San Francisco, Cal.

VK3UZ Silent

Station VK3UZ, which formerly was very active on 34 meters, has been taken off the air by its owners, Nilsen's Broadcasting Services, Pty., Ltd., Melbourne.

A New One For Canada

A new Canadian station that is coming through with great strength is VE9DR, on 49.96 meters. This is located at Drummondville, and relays the programs of CFCF of Montreal. It may be heard during the evening hours in the United States.

"Verification" from Sydney

"We have pleasure in quoting hereunder the schedules of our short-wave stations VK2ME and VK3ME:

"VK2ME broadcasts every Sunday from 0600 to 0800 G.M.T. (1:00 to 3:00 a. m., E.S.T.); 1000 to 1400 G.M.T. (5:00 to 9:00 a. m.); and 1430 to 1630 G.M.T. (9:30 to 11:30 a. m.)

"VK3ME broadcasts every Wednesday and Saturday from 1000 to 1130 G.M.T. (5:00 to 6:30 a. m.)

"The former station is situated at Pennant Hills on the outskirts of Sydney, and the latter at Braybrook on the outskirts of Melbourne.

"Included in the VK3ME program is a short resume of local news, whilst the VK2ME program has incorporated talks upon Australia, including natural history, tourist resorts, industries, etc. Both programs include a good percentage of music."

Amalgamated Wireless (Australasia), Ltd., A. S. McDONALD, Assistant Manager, 47 York Street, Sydney, Australia.

Both VK2ME and VK3ME use a frequency of 9,590 kilocycles or a wavelength of 31.28 meters.

Only One Siamese Station

The following letter is self-explanatory:

"Beg to inform you that our present short-wave broadcasting station is HS2P, call sign 'Radio Bangkok, at Phya Thai,' on 31.6 meters. This station is, however, still undergoing a series of tests for international purposes on 41 meters, 2.5 kilowatts, every Monday from 1400 G. M. T. to 1600 G. M. T. (9:00 to 11:00 a. m., E. S. T.).

"The opening and closing announcements are made in Siamese, English and French, but during the programs only Siamese and English are employed for announcing.

"The skeleton program for this station is as follows (Eastern Standard Time is given):

"9:00 a. m. The station opens with gramophone records of Siamese music.

"9:30 a. m. News bulletin in Siamese and English.

"9:45 a. m. Gramophone records of European music.

"11:00 a. m. The station closes down.

"Radio Bangkok may be readily recognized by its distinctive 'note call' in the form of a chime of six notes, up and down the scales of a gong at various intervals during the program.

"I may add that HS2PJ, and any other short-wave station other than HS2P, which may be given in any of the lists in the U. S. A. or elsewhere, are *not correct*. All these stations were taken off from broadcasting service some time ago."

LUANG JAMNI KOLAKARN,
Manager, Broadcasting Service,
Post & Telegraph Department,
Bangkok, Siam.

British East Africa Active

"Our wavelength is 49.5 meters, power approximately two kilowatts. Call letters VQ7LO. The following is our weekly program (converted to E. S. T.):

Monday, Wednesday, Friday,	11:00 a. m. to 2:30 p. m.
Tuesday, Thursday,	11:30 a. m. to 2:30 p. m.
Saturday,	11:30 a. m. to 3:30 p. m.
Sunday,	11:00 a. m. to 1:30 p. m.
Tuesday,	3:00 a. m. to 4:00 a. m.
Thursday,	8:00 a. m. to 9:00 a. m.

"Our programs consist of press news, overseas and local; music, popular and classical; book reviews; sport news; market reports; religious services; and information of general interest."

IMPERIAL & INTERNATIONAL COMMUNICATIONS, LTD.,
Nairobi, Kenya Colony,
British East Africa.

An Explanation

Most of the short-wave broadcasting stations of the world are more or less of "experimental" nature, and therefore do not stick to their announced operating schedules as closely as listeners would like them to. Sometimes their own announcements, both over the air and through the mails, contain conflicting information as to wavelength and hours of operation. *SHORT WAVE CRAFT* is constantly in touch with stations all over the world, and publishes only such data as it *knows* is reliable and authentic. Readers are invited to double-check what appears in this department, as occasionally a schedule will change while the magazine is in the course of preparation.

Aluminum Box Shields

Beautiful Silver Dip Finish

5 x 5 x 5 Knocked-down Coil Shield (like pictured on right)	\$1.00
5 x 9 x 6	1.87
6 x 10 x 7 Monitor Size	3.25



Bent (Undrilled) "Stand-By" Chassis	\$.75
BEST Converter Cabinet	3.45
Coil Cover "Cap"35
We make any size to order. Alcoa Shield Plate25

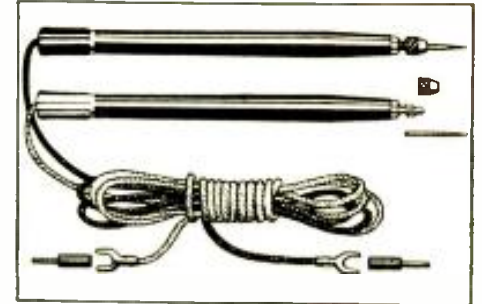

"BUDDY" Test Prods

Always sharp pointed, using phonograph needles, 4 ft. wires, spade or phone tips. Colored nipples identify each lead.
75c each. \$1.50 per pair.

WRITE FOR WHOLESALE PRICES

No. 47 PENTODE ADAPTERS enable you to use Pentode Tubes in your '45 Sockets. 25% increase in volume—No Wiring! Each \$.95

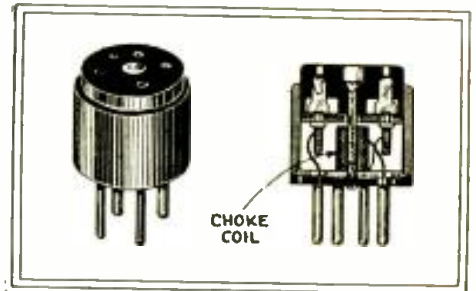

Isolantite Coil Forms, 4-5-6 prongs, each	\$.69
Octo Coil Forms, 4 prongs39
Pilot Coil Forms, 5 prong33
Double Spaced National Condenser for "Stand-By"	2.25
2-Plate Midget Condensers45
X-L Variodenser39
BEST Converter Coil Assembly.	

Lowest Price
Sponge Rubber Phone Cushions. 50c pair



Hammarlund EC80

WE SPECIALIZE IN RADIO PARTS
EXCLUSIVELY — parts furnished for
any kit in any magazine.

Please include sufficient postage

BLAN, The RADIO MAN, Inc.

Dept. SWC 632

89 CORTLANDT ST. NEW YORK, N. Y.

AERO WORLDWIDE SHORTWAVE RECEIVER

\$6.45

Listen in DIRECT to London, Paris, Berlin, Buenos Aires and other broadcasting stations throughout the world via short waves. Your ordinary receiver cannot tune in these low wave stations. **WORLD-WIDE RECEIVER** gets 14 to 550 meters.



AERO SHORT WAVE CONVERTERS
Convert Your Present Set Into a Short Wave Super-Heterodyne
A. C. MODEL \$12.50—D. C. MODEL \$11.50

AT LAST! The Perfect Auto Radio, ONLY \$20.00
Built by pioneers in the manufacturing of Auto Radio. We guarantee 1,000 miles radius of reception. A masterpiece of Radio engineering. Latest model 6 Tube Aero Pentode Auto Radio. Price of set only \$20.00. Set complete with tubes, batteries, dynamic speaker, antenna equipment and noise suppressors. \$39.50.

NEW AERO MIDGET

Using the Latest Type Pentode and Multi-Mu Tubes.
PRICE \$16.50

We guarantee **COAST TO COAST RECEPTION**
Wonderful tone quality and selectivity. Full dynamic speaker. Full vision dial. Beautiful walnut cabinet. 5 Tube Set \$16.50, less tubes. Complete set of 5 matched tubes \$4.50 extra.

SEND FOR COMPLETE CATALOG.



CHAS. HOODWIN COMPANY
4240 Lincoln Avenue
Dept. N-17 Chicago, Illinois

A Pleasant Surprise read the EDITORIAL

DATAPRINTS!!

ARRIVED AT LAST!

Blueprint Construction Data for Building Apparatus that many amateurs have longed to own, but lacked the Construction Data.

- How to build 1/16 H.P. 110 volt A.C. 60 cycle motor (Suitable for Television).....\$1.00
- How to build 60 cycle Phonic Wheel..... .50
- Data for a 1,200 cycle Phonic Wheel..... .50
- Construction data for powerful battery electromagnet..... .50
- Data for 110 volt, D.C. magnet to lift 25 pounds..... .50
- Data for 110 volt, D.C. Solenoid to lift 2 pounds through 1 inch..... .75
- Data for 110 volt, D.C. Solenoid to lift 6 pounds through 1 inch..... .75
- Data for 12 volt, D.C. Solenoid to lift 2 pounds through 1 inch..... .50
- Tesla or Oudin coil data for 30-36" spark..... .75
- Tesla or Oudin coil data for 6 to 8" spark..... .75
- Transformer data: 100 to 5,000 watts (1 primary and 1 secondary) (specify size and voltage desired)..... 1.00
- Home Refrigerating Machine..... 1.00
- Telegraphone (records voice on steel wire)..... .75
- 10 Short wave operating kinks..... .75
- 10 Television operating kinks..... 1.00 (Including lens disc and crater tubes.)
- Electric chime ringer for ordinary clocks..... .75
- Electric Ice Skates—how to make..... .75
- How to Thaw Pipes Electrically..... 1.00
- 20 Motor Circuits..... 1.00
- 20 Telephone Hook-ups..... 1.00
- 20 Tests for Motor Troubles..... 1.00

Send Check or Money Order (cash at own risk) no stamps. Prices quoted are postpaid.
20% discount on orders for \$5.00 or more.

The DATAPRINT Company
Lock Box 322 RAMSEY, N. J.

Building a Short Wave Super-Het

By A. POLTHEIM

(Continued from page 405)

forget the "ground," which is carried out by means of a metal plate fastened under the base-board and projecting somewhat.

This metal plate serves at the same time for strengthening the base-board. The shield cans have in the side wall a slit for the condenser shaft.

Short Wave Coils

The short-wave coils for the input circuit (L1, L2, and L3) are made of .06-inch (No. 14 B. & S. gauge) copper wire, in the form which may be seen in the photo.

To simplify this work, make a simple winding device (Fig. 7); this is a wooden cylinder 3 1/4 inches in diameter and 4 inches long, provided with four grooves.

Into these grooves are put the insulating rods with slots .06-inch wide (see Figs. 8 and 9), whereon the wire is wound. After the necessary number of turns have been applied, the wire ends are temporarily fastened and the slots of the holding pieces are smeared with a thick solution of celluloid in acetone. After perfect drying, which takes some 10-12 hours, the coils can be removed from the "mold." The distance apart of the windings is always 0.2-inch. To be able to cover the entire band, a whole set of coils is needed, made with the following numbers of turns: 2x1, 2x2, 3, 4, 6, 8, and 10 turns. The bases for the coils consist of small celluloid or bakelite plates, which are provided with two 0.16-inch prongs 1/4-inch apart. They are glued on with a solution of celluloid ce-

ment (already described). All the coils must be wound in the same direction, to make them interchangeable.

The construction of the receiver is clear from the front panel view. The front panel (plan for drilling Fig. 10) is 16x6.8 inches. The base-board is 16x8 inches. The two variable condensers are mounted on standards about 4 inches from the panel, and are turned by insulated extension rods. The tuning condenser is provided with a fine adjustment (vernier) dial. See to it that there is no lost motion (on turning the dial); since that makes tuning very difficult. It is desirable to make the standards of the condensers somewhat elastic; since almost all extension rods are a little off in alignment. By leaving a little leeway, a break is avoided and even rotation is attained.

Behind condenser C1 is arranged the coil holder, which consists of an insulating panel set up high, and provided with two pairs of sockets. The holder for the antenna coil is so fastened that it can be turned.

Beside these parts, there is the socket for the first tube and the antenna choke. The latter is wound on a tube 1.2 inches in diameter and 2.4 inches long; and has 150 turns of No. 32 wire insulated with cotton.

On the right side of the baseboard are mounted the intermediate- and audio-frequency parts. The transformer is so arranged that the shaft of the condenser passes through the hole in the panel, and can be turned from there.

Letters From S-W Fans

(Continued from page 408)

INTERNATIONAL AMATEUR RADIO SOCIETY

Editor, SHORT WAVE CRAFT:

Have just been looking over the October and November issue of SHORT WAVE CRAFT. I wish to congratulate on the fine articles you have in this issue. I believe your magazine is the best one of its kind, for the person who is interested in the short waves. In the past I have built many of the transmitters and receivers described, and wish to say that they certainly worked very good, and many of the other readers, with whom I correspond, say the same.

I would like to announce the *International Amateur Radio Society*, a world-wide organization of persons who are interested in short waves. Our purpose being: to help further the progress of the short waves. We have members in all parts of the world. We have no club magazine but suggest SHORT WAVE CRAFT to all members. I would like to hear from other readers of "SWC", who are interested in the club; for information address: "International Amateur Radio Society, 15 1/2 N. Main St., Three Rivers, Mich."

The "junk pile" up here at WSEYD consists of a Hartly circuit, employing a type 210 tube as oscillator, 250 as modulator, and three 227's as speech amplifiers, two of the 227's being in parallel. The antenna system has a flat-top portion of 132 feet with additional 40 feet Zeppelin feeders. As a station receiver I use a Pilot A.C. Super-Wasp, which has been revamped to make a full dial spread on the various bands. Simple as the outfit may sound, I have worked all districts in the U. S., and hope to reach out for some real DX soon.

As the I. A. R. S. and myself are 100% short wave hounds, and boosters of SHORT WAVE CRAFT, I would like to see this letter published,

if convenient. We all wish you much success, and a big 1932.

Yours truly,
EUGENE C. MILLER, W8EYD.
President, I.A.R.S.,
Three Rivers, Mich.

(Welcome to our midst. The more societies and the more organizations in the short wave field, the quicker the gospel of "short waves" will travel all around the world. SHORT WAVE CRAFT wishes the new society every success.—Editor.)

NOT BAD WE SAY

Editor, SHORT WAVE CRAFT:

I am a regular reader of your magazine and I think it is the BEST. I like your S. W. Log fine; it sure helps you when you want to find a station.

I am the owner of a Geo. W. Walker Flexi-Unit S.W. adapter; and it certainly is great. Some of the S. W. stations that I have picked are: VE9GW, Bowmanville; VE9CL, Winnipeg; G5SW, Chelmsford; KKZ, Bolinas; HRB, Tegucigalpa, Honduras (on every night now); 7LO, Nairobi, Kenya, Africa, operating on 49.5 meters with 2,250 watts. 7LO announces in English and Swahili.

I also receive a station between W8XK, 25.25, and G5SW, 25.53, every Tuesday, Wednesday, Thursday from 1:30 P. M. C. S. T. until 4:30 P. M. They have an opera; announcements are made by a man and a woman. It is neither English, French or Spanish. At 4:30 P. M. C. S. T. they have chimes. If any one can tell me what station this is I would sure thank them.

FRED D. FISHER,
1627 So. McClure,
Marion, Ind.

New Harrison S-W Receiver

A NEW short wave receiver that is arousing considerable interest in the ranks of the short wave fans and among the amateurs is the ROYAL Model RP. Although on the market for only a short time it is already piling up enviable reception records comparable with those of much higher priced receivers. Letters received from the owners of these sets contain glowing accounts of the reception of foreign broadcasts, code stations in all parts of the world, airplane conversations, police transmissions, etc., many of them with surprising "loud-speaker" volume.

One of its outstanding features is the extremely low price which places it within the reach of everyone, even those short wave enthusiasts with limited means.

The receiver is a masterpiece of advanced short wave design embodying every new worth-while development. The proper use of only two tubes, a 32 screen grid detector and a 33 power pentode output tube, gives this model the sensitivity and volume of an ordinary four tube set. This receiver is battery-operated in order to eliminate hum and other objectionable noises frequently encountered in "AC" operated sets. By virtue of using the new economical, two volt tubes, one set of batteries, with ordinary use, will last approximately six months. To fully utilize the tremendous gain of the screen grid tube a special reactance, resistor, capacity coupling is used. The regeneration control is smooth acting and at the same time functions as a volume control. The same knob also operates an automatic switch.



This Royal S-W receiver is available in two types, "Regular" and "Band Spread." The amateur will be interested in the latter type as it has the 20, 40 and 80 meter bands widely spread for ease in tuning. This type is not designed to cover the rest of the Short Wave spectrum and all other Short Wave "bugs" are advised to purchase the "Regular," which covers from 14 to 200 meters. A special coil will extend its range to 550 meters.

The set is constructed on a heavy cadmium chassis, which effectively shields the various circuits. A full vision, micro-vernier dial with a smooth ratio of 5 1/2 to 1 enables the operator to easily tune for maximum results.

As seen in the illustration, the finished set is housed in an attractive crackle-finished metal cabinet, which aside from enhancing the appearance of the set, completely eliminates all hand capacity effects.

This short wave receiver fills a long-felt want and is ideal for the novice and the experienced Short Waver.

This set is manufactured by the Royal Short Wave and Television Company of New York City, pioneer constructors of short wave apparatus.

STUDY THESE DIAGRAMS !

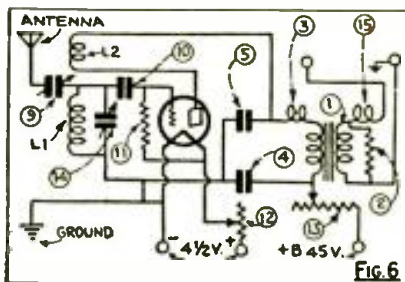

. . . and learn how to build these and FIFTY other SHORT WAVE RECEIVERS in the newest and most popular of Short Wave Books. . . .

Order
Your
Copy
Now !

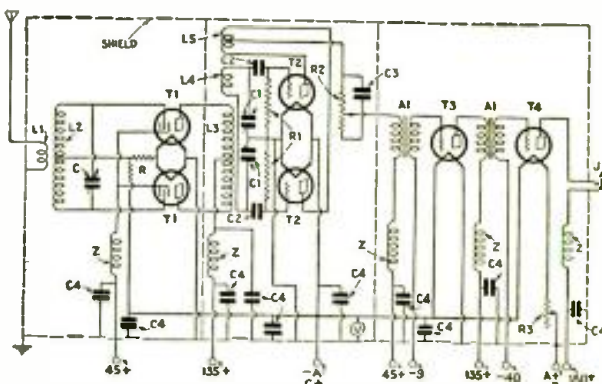

ON the lips of thousands of Short Wave enthusiasts—in the shops and homes of thousands of "hams"—HOW TO BUILD AND OPERATE SHORT WAVE RECEIVERS is now recognized as the GREATEST BOOK OF ITS KIND EVER PUBLISHED.

We hear favorable comments everywhere—the ether is chock full of gossip by "hams" about the Short Wave Book. Those in the "know" have written us that they have found this book most instructive and makes a valuable addition to their Short Wave Library.

EVERY SHORT WAVE ENTHUSIAST SHOULD HAVE A COPY

The book has been edited and prepared by the Editors of SHORT WAVE CRAFT, and contains a wealth of material on the building and operation, not only of typical short wave receivers, but short wave converters as well.

USE COUPON This Book is Not Sold on the Newsstands

A Few of the Good Articles

- The "S. W. C." Two Tube Portable Works "Speaker"—Clyde Fitch
- How to Operate a Short Wave Receiver Two-Volt Tube Receiver
- A "Plug-less" S. W. Receiver—John M. Avery
- "My Favorite" Short Wave Receiver—F. H. Schnell
- The HY-7B Super-Het for A.C. Operation—L. W. Hatry
- The "Egert" SWS-9 Super-Het—How to Make It—Joseph I. Heller
- A Super Sensitive Short Wave Receiver—Thomas A. Marshall
- A S. W. Power Amplifier—H. Winfield Secor
- How to Obtain Smooth Regeneration in S. W. Receivers—"Bob" Hertzberg

50c. The Copy

SHORT WAVE CRAFT
96 Park Place
New York City, SWC-2-6

Gentlemen:—
I enclose herewith fifty (50c) cents for which please send me a copy of your new book, HOW TO BUILD AND OPERATE SHORT WAVE RECEIVERS. (Send money order, check, cash, or new U. S. Stamps. Register letter if it contains currency.)

Name

Address

City and State

F. & H. CAPACITY AERIAL



Price \$1.00 Complete postpaid

Every Instrument Tested on Actual 1127 Mile Reception

A LARGE NUMBER ARE IN USE BY GOVERNMENT, IN NAVY HOSPITAL

The F. & H. Capacity Aerial Eliminator has the capacity of the average 75-foot aerial, 50 feet high. It increases selectivity and full reception on both local and long distance stations is absolutely guaranteed. It eliminates the outdoor aerial along with the unsightly poles, guy wires, mutilation of woodwork, lightning hazards, etc. It does not connect to the light socket and requires no current for operation. Installed by anyone in a minute's time and is fully concealed within the set. Enables the radio to be moved into different rooms, or houses, as easily as a piece of furniture.

8,000 dealers handle our line. Dealers! Over 80 leading jobbers carry our line or order sample direct. Write for proposition.

SEND COUPON, IT PROTECTS YOU

Name
Address
City State

Send one F. & H. Capacity Aerial with privilege of returning after 3-day trial if not satisfactory, for which enclosed find check M. O. or dollar bill, or send C. O. D. Send Literature, Dealer's proposition.

F. & H. RADIO LABORATORIES
Fargo, N. Dak. Dept. SC

Can We Radio Mars?

(Continued from page 378)

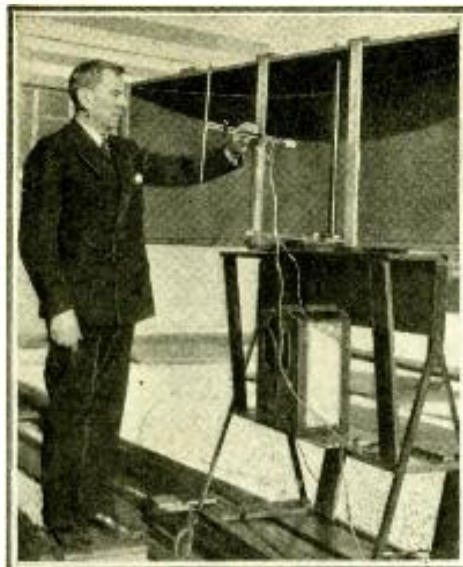

Dr. Mourmtseff at the 16" wave receiver.

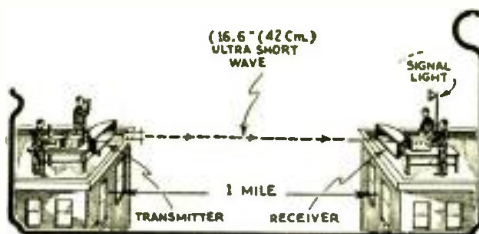

Talking over 1 mile on 16" waves.

that all radio, or 'dark light' waves less than seven meters long will penetrate that layer and leave the earth.

"It is conceivable that the power we have succeeded in getting into our 42-centimeter beam is sufficient to pierce the Heaviside layer and travel the 35,000,000 miles to Mars. It is possible that such small power may carry to such great distances, because of the fact that practically all of the intervening space is really a high vacuum and does not, therefore, absorb the waves, once they get through the earth's atmosphere."

Now Talking—1 Mile on 16-Inch Waves

Today Westinghouse research engineers are talking on such a beam from station W8XI, on top of the research building, to the roof of the engineering laboratory, more than a mile away, where a parabolic metal mirror gathers the waves, and passes them through a special detector tube to an ordinary little radio receiving set where they are amplified and made audible.

Radio beams are identical with light beams except that they are of different frequencies or wavelengths and invisible according to the engineers. In actual service, communication on the radio-optical waves is dependable and almost immune to theft, interruption and interference. Its operation cannot easily be "jammed", or crippled by an enemy, the beam must be found before its message can be detected and by means of reflecting surfaces, it can be sent long distances, says Mourmtseff.

We didn't want the industry to out-grow its most important publication so we made SHORT WAVE CRAFT A Monthly.

The next issue of SHORT WAVE CRAFT will be on the Newsstands, April 15

"HAM" ADS

Advertisements in this section are inserted at 4c per word to strictly amateurs or 8c a word (8 words to the line) to manufacturers or dealers for each insertion. Name, initial and address each count as one word. Cash should accompany all "Ham" advertisements. No less than 10 words are accepted. Advertising for the April-May issue should reach us not later than February 10.

SELLING CW TRANSMITTER with Jewell meters, complete with wavemeter, bargain. Condon Kirk, Niles, Michigan.

SHORT WAVE BLUEPRINTS: Send 35c (coin) and receive five short wave blueprints consisting of 1, 2, 3 and 4 tube D.C. and one five tube A.C. all wave midget. Build any one of these circuits and receive real D.X. results. S. Gordon, 1313-40th Street, Brooklyn, N. Y.

SACRIFICE \$150.00 MERCURY SUPER-TEN, 13-550 meters, batteries, A-1 condition, very good results. \$75.00. William Muehlenhart, 131 W. Kingsbridge Road, Bronx, N. Y.

LICENSED OPERATORS! Why not be regular Hams and QSL. Write for our samples and prices mentioning SHORT WAVE CRAFT. Maleco, 1512 Eastern Parkway, Brooklyn, N. Y.

PLUG-IN COILS—Set of four wound on bakelite forms. 50c per set. Noel, 1502 Pittston Avenue, Scranton, Pa.

VK3ME verified reception with Oliver Amille's "Conquest". Complete kit: Low-Loss coils; everything. Postpaid \$11.95. Ham list 3c. Converters \$6.00. Thomas Blanchard, 438-N Ninth, Reading, Pa.

QSL CARDS. Snappy service on printing good quality two color QSL cards, stationery, message blanks. Write for free samples today. WIBEF, 16 Stockbridge Ave., Lowell, Mass.

SHORT WAVE LISTENERS CARDS. We print just the type of card you need for reporting the stations you hear. Write for free samples today. WIBEF, 16 Stockbridge Ave., Lowell, Mass.

METERS—Functioning Weston 301, 5 mills range, \$3.25. JEWELL 135 direct reading ohmmeter, 15,000 ohms range, \$2.50. Others. Also power, filament and audio transformers. Bodine phonograph motor with Stromberg Carlson pick-up for \$15.00. Also radio books. William Henry, Front Stret, Middletown, Conn.

You Can Become a Fast, Capable RADIO OPERATOR at Home

CANDLER Scientific Method

In less than the usual time you can get amazing results. Thousands of fast Radio operators taught by CANDLER. FREE advice if you're "stuck."

All questions answered personally. No obligation. If you are now a Radio operator, ask about ADVANCED COURSE for SPEED and Copying Behind, and "MILL" Course. FREE BOOK will save you time and money. Tune in on Candler Short Wave Station!

CANDLER SYSTEM CO., Dept. S.W. 6
6343 So. Kedzie Ave., Chicago, Ill.

"Passed amateur exam. with 3rd lesson." — E. Wilson, Toledo, Ill.
"Studied 11 hours, can copy 8 wpm." — E. J. Yarris, Chicago.



World's Only Code Specialist

Space Doesn't Permit—So we can't tell you all we would like to about the "HAWK" THE SENSATIONAL SHORT WAVE RECEIVER

Embodying latest design practices—Screen Grid R.F.—Screen Grid Detector—Pentode Audio. Full spreading facilities for "ham" and broadcast bands. Works loud speaker with tremendous volume. Priced sensationally low—only..... \$22 net

You are invited to drop in to see and hear this outstanding receiver value Write for circular.



25 WARREN ST. Dept. C NEW YORK

Heinrich Hertz Institute
By DR. ALFRED GRADENWITZ

(Continued from page 380)

Engineering, (3) High Frequency Engineering, (4) Acoustics, (5) Mechanics.

The following are some of the outstanding problems at present being investigated at this unique Institute:

In the field of *Electrical Vibrations*; the penetration of coils, particularly transformer coils, by electric waves, and the resulting electric stress upon the insulation of windings; the distortion of telegraph signals and telephone currents in long lines, as well as the means employed to counteract it;

In *Radio Engineering*; any problems connected with the radiation of waves and atmospheric disturbances, the problems of acoustic broadcasting and television, the choice of proper standards for the gauging of radio receivers, etc.;

In connection with *Acoustic Engineering*; a systematic investigation of sound components contained both in human speech and the sounds of musical instruments, all general problems of physiological acoustics, the testing of acoustic apparatus—telephones, microphones, loudspeakers—an investigation of proper conditions of satisfactory reproduction in a talking film; in architectural acoustics, the fundamental problems of sound transmission and the nullification of "noise," echoes, etc.; the acoustic insulation of rooms, the testing of sound insulators and of conditions on which the acoustic efficiency of halls is dependent, the gauging of resonance, etc.;

At the *Radio Laboratories* of the Institute, particular attention is, of course, given to short and ultra-short waves, the rooms set apart for these tests comprising an insulated coating of copper sheets under the floor which can be either earthed or used as electric counter-poise. Two high tension laboratories and a music studio have been provided on the uppermost story, below the roof.

One short-wave transmitter is used in ascertaining the distribution of field intensities in the case of ultra-short waves intermediary between 8 and 10 meters. A high-power ultra-short wave transmitter for a wavelength of 3 meters serves for physiological investigations. Again, in another room there is found an outfit for accurately measuring the frequency of short waves. A standard quartz crystal having been excited in one of its upper harmonics, interference is brought about with the frequency to be gauged.

Much attention is given in the Short-Wave Section to *Television* tests, there being several transmitters and receivers, special glow lamps for reproducing television images and apparatus for *Cathode Television*.

The Heinrich Hertz Institute of Wave Research is placed under the general directorship of Prof. K. W. Wagner, one of the highest authorities on telephone and radio engineering, and the Short-Wave Section is directed by another renowned physicist specializing in radio, Prof. G. Leithäuser, who also conducts the television tests.

A special experimental outfit enables any sounds to be analyzed as to their composition, the amplitude and frequency of component harmonics being recorded photographically.



The Television Trend...

SEND 15c FOR SAMPLE COPY (See Coupon)

Timely developments in radio's latest wonder, Television, are published in every issue of TELEVISION NEWS—Mr. Hugo Gernsback's latest magazine. Rapid advancement in this art today is becoming a repetition of the radio cycle of years ago. Daily broadcasts are becoming more numerous and experimenters are following in quick order in building television sets for experimental purposes. Foresight of its development can be seen by the pioneers of radio—they are equipping themselves now with television experience.

The articles published in TELEVISION NEWS are of primary importance to experimenters—they are simple in construction, understandable and replete with diagrams, photographs and illustrations.



A Brief Summary of Contents

Prominent Television Authorities

REPLOGLE — BAIRD — BLOCH — RAPPAPORT — NASON — CISIN — MURRAY

FEATURES:

- Editorial, "Must We Scan?", by Hugo Gernsback.
- Light Beam Television—Dr. Alexanderson's Remarkable Experiment.
- Televising Sun's Eclipse, by D. E. Replogle.
- Sub-Sea Television, by H. W. Secor.
- In the Television Eye.
- New European Television Kits.
- Possibilities of Ultra Short Waves for Television, by D. E. Replogle.
- Boston Television Station, by Hollis Baird.
- The Romance of Television, by Herbert Futran, Assistant to President of Sanabria Television Corp.
- A Simple Lens-Disc Projector—How to Build It, by Ivan Bloch, E.E.
- How Shall We Teach Television? by Sid Noel.
- Practical Hints on Cathode Ray Scanners, by M. Rappaport, E.E., Research Engineer, Television Mfg. Co. of America.
- Optical System for Controlling the Size of Crater, by Ivan Bloch, E.E.
- N. Y. Sun's 2nd "Prize Winner" in Television Set Building Contest.
- Fidelity Tests for Television Systems, by

- A. F. Murray, Research Department, R. C. A. Victor Company.
- Radio Frequency Operation of Neon Tubes, by Harry Waldron.
- The Braun Tube as a Transmitter.

TELEVISION RECEIVERS:

- A Simple Lens-Disc Projector—How to Build It.
- Cathode Ray Scanners—How to Use Them.
- A Drum Scanner, by M. Treuhafft.
- A Simple Motor Synchronizing System.
- Detector-less Television Receiver.
- 4-Tube Television and Broadcast Receiver, by H. G. Cisin, M.E.
- Pioneer Receiver and Scanner, by John J. Fettig.
- A New System for Television Synchronization.
- New "See-All" Television Models.

TRANSMITTERS:

- Television Transmitting Station, W1XAV, Boston.
- An A.C. Operated Transmitter, by I. R. Conrath.

Special Offer — Void After April 30

Television News, 98 Park Place, New York, N. Y.

SWC 2-6

Mark X in square which offer desired:

- As per your Special Offer, I enclose \$1.25 (Canada and Foreign \$1.50), for which enter my subscription to TELEVISION NEWS for one year.
- Send me a sample copy of TELEVISION NEWS for which I enclose 15c (U. S. Stamps or coin accepted).

Name

Address

City State





Real Bargains

100,000 ohm Variable 100 Watt Resistor.....	\$2.50
100,000 ohm 100 Watt Bleeder Resistors with Brackets	2.50
10,000 ohm Hardwick Hindle Wire Resistors.....	.35
R. C. A. Double Chokes	1.00
Jefferson Step Down Transformer, 110 volts to 25 volts	1.00
Telegraph Keys	1.25
Short Wave Converter	4.50
Air King Coil Set	1.75
866 Vapor Tubes	2.95
30 Henry Chokes75
Kenyon 3-1 Transformer75
Rauland Lyric 5-1 Transformer	2.50
R. C. A. Victor Hand Microphones	2.95
Kolster Magnetic Speakers	5.00
Polymet Single Button Microphone Trans- former	1.75
Polymet 2-Button Microphone Transformer..	2.25

Send 20% deposit with order or take 2% off if paid in full.

Send us your inquiries on anything you need

NUBOR RADIO, Inc.
Dept. K
310 Broadway New York City



Stoppani Belgian Compass

Being a precision instrument, the Stoppani Compass lends itself admirably for use in the Radio Experimenter's test laboratory. It affords an ideal means of determining the polarity of magnets, electro-magnets and solenoids carrying current. Since the compass needle is itself a magnet, having a North-seeking pole (which is actually the South pole) and South-seeking pole (which is actually the North pole); and since, as we all know, like poles attract each other and unlike poles repel each other, it is merely necessary to bring the compass in the vicinity of the magnet under test. The North pole of the compass needle will then point to the North pole of the magnet under test or the South pole of the needle will point to the South pole of the magnet depending, of course, upon their relative positions.

May Be Used As a Galvanometer

Because of its uniform magnetic properties, high sensitivity, and delicate frictionless bearings, the Stoppani compass may be utilized to advantage as a highly precise galvanometer for detecting electric currents in experimental or conventional radio circuits. The compass is easily and readily converted into said galvanometer by merely winding several turns of ordinary radio wire completely around the face and lower case of the compass; leaving small spaces between turns to observe the movements of the needle. The ends of the wire are brought out as test leads to be inserted in series in circuits under test. A deflection of the compass needle in either direction indicates the presence of an electric current. Incidentally the intensity of the current may be closely approximated since the force with which the needle vibrates is proportional to the intensity of the current flowing through the wire. Stoppani Compass is an ideal SURVEYORS instrument with elevated sights. It is made of Solid Bronze, Parkerized, non-rusting, graduated in 1/10, Ruby Jewelled, 4 inches square. Fitted in a hardwood case, with set screw in corner to hold needle fixed when not in use. The United States Government paid more than \$30.00 for this precision instrument.

Our Price \$4.50

Gold Shield Products Company
102 Chambers Street SWC New York, N. Y.

The New Hammarlund All-Wave "Comet"

By LEWIS MARTIN

(Continued from page 394)

and seriously limiting the usable amount of intermediate amplification.

The type '47 pentode is used as the output or last stage audio amplifier. This tube makes an ideal combination with a '24 type screen grid tube operated as a linear power detector. Such a detector, resistance-capacity coupled, easily provides sufficient input voltage to the grid of the pentode, thus obviating the need for transformers or an intermediate audio stage. The resistance-capacity coupling between power detector and output tube preserves the fidelity of the detector output and results in exceptionally clean and faithful reproduction of speech and music. A tone control is provided in the plate circuit of the pentode, which enables the listener to modify the response at the higher audio frequencies to suit.

The "Station Finder"

An important feature of the "Comet" is the "long-wave" oscillator, which can be started and stopped by a switch on the panel. It consists of a '27 type tube and associated circuits and its output is loosely coupled *capacitively* to the grid of the second detector. Its circuits are adjusted to oscillate at 465 K.C., which is the frequency for which the intermediate amplifier is tuned. Inasmuch as all incoming signals, of whatever frequency, are shifted to 465 K.C. by the action of the heterodyne oscillator and the first detector (or mixer) it will be evident that starting the 465 K.C. oscillator will produce an audible beat note (or whistle), since the signal (coming through the intermediate at approximately 465 K.C.)

and the output of the beat oscillator are both impressed on the grid of the second detector. Thus the "Comet" is ideal for pure C.W. reception—the pitch of the beat can be adjusted to suit by means of the left hand vernier which controls the heterodyne oscillator. Although this feature is primarily intended for C.W. code reception, it is also extremely useful in searching for all signals. It is quite easy to skip right over stations, especially when tuning in the very short waves. However, all chance of missing a station can be avoided by first turning on the long wave oscillator. Then as the main tuning dial is slowly turned a loud whistle will be heard each time a carrier wave is crossed. When such a whistle is heard it is a simple matter to adjust the dial for zero beat (approximately), which makes the whistle low in pitch. This process automatically tunes in the signal very accurately. After turning off the oscillator speech or music will be heard provided the carrier is that of a phone or broadcasting station.

The use of type '35 variable mu tubes in the intermediate stages assures extremely smooth control of the amount of intermediate amplification between wide limits. The actual control consists of a tapered wire-wound variable resistance in series with the cathodes of the two intermediate amplifier tubes. By this means the loud speaker output may be adjusted to suit whether the signal be from a powerful nearby station or from a foreign station thousands of miles away.

The receiver is substantially "single control".

Letters From S-W Fans

(Continued from page 426)

FOUR COUNTRIES IN A WEEK!

Editor, SHORT WAVE CRAFT:

Congratulations on the new SHORT WAVE CRAFT. All that we "Hams" have to wish for now is to have it come out every month.

Did anybody notice the perfect reception conditions dished out to Ohio and surrounding States during the week of Dec. 5-12? After operating my National Thrill Box (battery model) for about six months, I had a total of 10 countries. During this week I have added four stations in three countries. My record to date: U. S., N. Y. to Calif.; Mexico, 1; Canada, 2; Honduras, 1; Brazil, 1; Argentina, 2; Chile, 1; England, 3; Germany, 1; Italy, 1; Holland, 1; France, 2; Hawaii, 1.

All on an 18-inch magnetic speaker at full room volume. I don't use the 'phones much because everything sounds muffled with them on. The South Americans on 14 meters are coming in exceptionally good between 1-5 p. m. E.S.T. Incidentally, here's one for Bob Hertzberg: That Chilean station on the call list at 15,257 meters—19,600 kilocycles is CEC, Santiago. They are heard from 1:30 p. m. onward, testing with PPU in Rio de Janeiro, Brazil. The text of the program is the reading of books, just to keep up a steady flow of speech so that the Brazilian PPU can get their receivers set.

Hoping this "info." may be of some service to your readers, I remain,

FRANK MATYAC.
"Royal Order of S. W. P. II."
248 Jackson St.,
Columbus, Ohio.

(Not bad at all we say, Frank, and more power to you. That is the way we like to have the short wave phone hounds speak their piece. —Editor.)

FROM ENGLAND

Editor, SHORT WAVE CRAFT:

I have been reading SHORT WAVE CRAFT since No. 1 and I think it is the finest ever published on "S.W.'s". But I have a suggestion to put to you and that is, why not keep all articles toward the front of the "mag.," and advertisements at the back. I myself do not like to start reading an interesting article, reach the bottom of the page and then see "turn to page —." Is it essential for all headings to be at the top of the page; they would certainly be in different positions, but what of that.

Another thing: Please do not include any tall yarns in your "mag." You will ruin it if you do. We can buy those kind of things at any bookstall. *What we want—and I know I am speaking for lots of other "hams"—are CONSTRUCTIONAL ARTICLES of any and every description.* They are sure to be interesting if published in "S. W. C." A while ago I heard a rebroadcast from WGY on 19.56 m. relaying a program from Germany. I used untuned S.G. detector, one audio. 19.56 meters is about the most consistent over here. I get him nearly every night. You may publish this if you wish. May your circulation increase, and may the sun never set on "S. W. C."

Yours sincerely,

FRANK DEVERALL,

52 Loop Rd.,

Kingfield, Woking, Surrey, England.

P. S.—You asked for it.

(Thanks, "Cousin" Frank, but as you will have seen from the last few issues of SHORT WAVE CRAFT we are just bristling with constructional articles. We believe you will have little to complain of along this line in the future.—Editor.)

a very fine adjustment for the oscillator tuning and proves helpful when receiving the very short waves. The right hand vernier controls the wavelength tuning and is most valuable in receiving the longer waves. Under ordinary operating conditions most stations can be tuned in with the main control alone irrespective of vernier settings.

~ DATA ON COMET COILS ~

COIL NO.	WAVELENGTH RANGE METERS	PRIMARY		SECONDARY		LENGTH OF WINDING	T.P.I.
		NO. TURNS	WIRE SIZE	NO. TURNS	WIRE SIZE		
1-OSC.	14-30	4	№30 D.S.C.	6	№20 D.S.C.	1.000"	6
1-W.L.	14-30	4	" "	7	" "	1.167"	6
2-OSC.	28-60	4	" "	12	" "	1.000"	12
2-W.L.	28-60	4	" "	14	" "	1.167"	12
3-OSC.	56-125	5	" "	24	" "	1.000"	24
3-W.L.	56-125	5	" "	33	" "	1.375"	24
4-OSC.	120-300	10	" "	44	№28 S.S.C.	.765"	56
4-W.L.	120-300	5	" "	78	19/41 LITZ	1.393"	56
5-OSC.	240-550	14	" "	70	№28 S.S.C.	1.250"	56
5-W.L.	240-550	8	" "	114	TWO BANK 19/41 LITZ	1.062"	

ALL COILS WOUND ON ISOLANTITE FORMS 1 1/2" DIAMETER. ALL PRIMARIES WOUND IN GROOVE 3/16" WIDE, 1/64" DEEP SPACED 1/16" FROM SECONDARY

INTERMEDIATE TRANSFORMER COILS

TWO "UNIVERSAL" WINDINGS OF 19/41 LITZ WOUND ON TREATED WOODEN CORE 9/16" DIAMETER. EACH COIL HAS INDUCTANCE OF 1.2-MH. AND THE TWO COILS ARE SPACED 3/32" APART

INTERMEDIATE (LONG WAVE) OSCILLATOR COILS

TWO "UNIVERSAL" WINDINGS OF №32 D.S.C. WIRE WOUND ON TREATED WOODEN CORE 9/16" DIAMETER. EACH COIL HAS INDUCTANCE OF .5MH. AND THE TWO COILS ARE SPACED 1/4" APART.

A 4 to 7 Meter Receiver That Works!

(Continued from page 409)

to operate a neon crater tube (or cathode tube), additional stages of A.F. amplification can be added to the set. The N. B. C. image has been seen by one observer with a receiver of this type, using a "120 lens" disc, with a neon crater tube placed behind it, the disc being rotated at 24 revolutions per second. Of course to receive both *voice* and *image*, two receivers are necessary, one to tune in the voice, and the other to tune in the image. The authors have found this receiver to work excellently with an indoor antenna of the size mentioned; to the ground post we may connect either a ground wire, or else a "counter-poise," consisting of another wire from 6 to 10 ft.—Data and diagram by courtesy of United Radiobuilders.

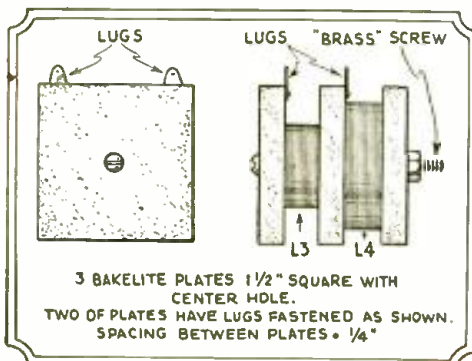

Detail of special transformer.

Make Money with PHOTO CELLS!

The New LUXTRON CELL and R-1 RELAY



REQUIRES NO AMPLIFIERS
Size 6" x 3 1/4" x 3 1/2" deep LUXTRON R-1 RELAY (shown in case).

ONLY \$4.00

(Less Gum-wood Case)

Open up a Brand New Money-Making Field to Fans, Experimenters and Service Men.

Make Big Money Constructing and Installing Automatic Control Devices!

Get Started Now in this New and Profitable Business. Exclusive Territory Still Available.

An Enormous Market is waiting for the numerous light-operated Controls you can make with the inexpensive LuxTron Kit.

Hundreds of practical applications: Fire alarms, burglar alarms, smoke indicators, counting, sorting, color matching, automatic sign lighting switches, etc.

COMPLETE KIT ONLY \$9.50
(Never Before sold for Less Than \$60.)

This includes:

- 1—Light-sensitive Luxtron Cell, type "ST"
- 1—Relay Controlling 110-volt Circuit, type R-1
- 1—Gum-wood Relay Cabinet
- 1—Complete Set Instructions and Diagrams showing how to make automatic parking light control for automobiles.



Size 1 1/2" x 3/4" x 3". Active Area 1" x 1 1/2". THE LUXTRON CELL operates at 22 1/2 volts. No amplification needed to operate relay.

ONLY \$3.50

SEND \$1 ONLY FOR INTERESTING INSTRUCTIONS AND DIAGRAMS

LUXTRON DEVICES COMPANY

Pioneers in Photo Cell Devices Since 1900

338 BERRY STREET

BROOKLYN, N. Y.

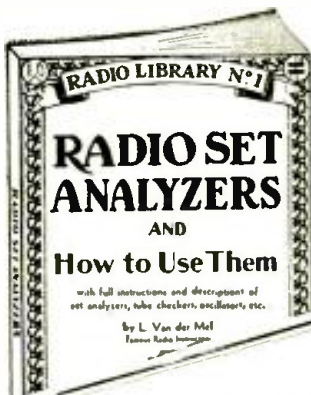

A Timely NEW Radio Publication

JUST OFF PRESS!

If you are a Radio Service Man or if you intend becoming one, this book is absolutely invaluable to you. It goes into every phase of testing and gives you the very information you have been looking for. It contains also complete description and hookups of important analyzers on the market. Fully illustrated with important diagrams, hookups and other illustrations. The only book of its kind in print.

Send fifty cents today for your copy

GERNSBACK PUBLICATIONS, Inc.

98N Park Place

New York, N. Y.

GET POLICE CALLS

on your Present Radio by attaching a BUD POLICE THRILLER to it.

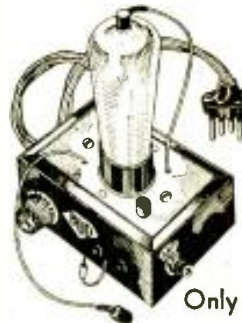

You can listen to Police Calls, Riot Calls, Naval Stations, and Amateur Stations. Fits any Electric Radio. Easy to Install.

Only \$3.50

BUD POLICE THRILLER when connected to broadcast receiver changes the tuning from 80 to 200 meters on the broadcast receiver. This will enable you to bring in short wave reception in addition to your regular broadcast programs. Guaranteed to work on your Radio Set or money will be refunded.

BUD RADIO INC.

1923 E. 55th St.

Cleveland, Ohio

... Uninterrupted Interest

Readers of this magazine will herald the news that SHORT WAVE CRAFT is now a monthly. Our editors received thousands of letters from enthusiasts with the request that we make this publication a monthly so that they can better keep abreast of new developments in this fascinating field. SHORT WAVE CRAFT has turned an attentive ear to the requests of its followers. We thank the many thousands for their support of the bi-monthly and hope that they will continue to enjoy SHORT WAVE CRAFT in its new form.

I will train you at home to fill a **BIG PAY** Radio Job!



Here's Proof



\$100 a week

"My earnings in Radio are many times greater than I ever expected they would be when I enrolled. They seldom fall under \$100 a week. If your course cost four or five times more I would still consider it a good investment."

E. E. WINBORNE
1267 W. 48th St.,
Norfolk, Va.



Jumped from \$35 to \$100 a week

"Before I entered Radio I was making \$35 a week. Last week I earned \$110 servicing and selling Radios. I owe my success to N. R. I. You started me off on the right foot."

J. A. VAUGHN
Grand Radio & Ap. Co.
3107 S. Grand Blvd.
St. Louis, Mo.



\$500 extra in 6 months

"In looking over my records I find I made \$500 from January to May in my spare time. My best week brought me \$107. I have only one regret regarding your course—I should have taken it long ago."

HOYT MOORE
R. R. 3, Box 919,
Indianapolis, Ind.

If you are dissatisfied with your present job, if you are struggling along in a rut with little or no prospect of anything better than a skinny pay envelope—clip the coupon NOW. Get my big FREE book on the opportunities in Radio. Read how quickly you can learn at home in your spare time to be a Radio Expert—what good jobs my graduates have been getting—real jobs with real futures.

Many Radio Experts Make \$50 to \$100 a Week

In about ten years the Radio Industry has grown from \$2,000,000 to hundreds of millions of dollars. Over 300,000 jobs have been created by this growth, and thousands more will be created by its continued development. Many men and young men with the right training—the kind of training I give you in the N. R. I. course—have stepped into Radio at two and three times their former salaries.

Get Ready Now for Jobs Like These

Broadcasting stations use engineers, operators, station managers, and pay up to \$5,000 a year. Manufacturers continually employ testers, inspectors, foremen, engineers, service men, buyers, for jobs paying up to \$6,000 a year. Radio Operators on ships enjoy life, see the world, with board and lodging free, and get good pay besides. Dealers and jobbers employ service men, salesmen, buyers, managers, and pay up to \$100 a week. My book tells you about these and many other kinds of interesting radio jobs.

Many N. R. I. Men Have Made \$200 to \$1,000 in Spare Time While Learning

The day you enroll with me I'll show you how to do 28 jobs, common in most every neighborhood, for spare time money. Throughout your course I send you information on servicing popular makes of sets; I give you the plans and ideas that have made \$200 to \$1,000 for N. R. I. students in their spare time while studying. My course is famous as the course that pays for itself.

Talking Movies, Television, Aircraft Radio Included

Special training in Talking Movies, Television and Home Television experiments, Radio's use in Aviation. Servicing and Merchandising Sets, Broadcasting, Commercial and Ship Stations are included. I am so sure that N. R. I. can train you satisfactorily that I will agree in writing to refund every penny of your tuition if you are not satisfied with my Lessons and Instruction Service upon completion.

64-Page Book of Information FREE

Get your copy today. It tells you where Radio's good jobs are, what they pay, tells you about my course, what others who have taken it are doing and making. Find out what Radio offers you without the slightest obligation. ACT NOW!

J. E. SMITH, President
National Radio Institute Dept., 2DB3
Washington, D. C.

Our Own Home
Pioneer and World's Largest Home-Study Radio training organization devoted entirely to training men and young men for good jobs in the Radio industry. Our growth has paralleled Radio's growth. We occupy three hundred times as much floor space now as we did when organized in 1914.



Special Free Offer

Service Manual on Trouble Shooting in Radio Sets Sent Free



Act now and receive in addition to my big free book "Rich Rewards in Radio," this Service Manual on D. C., A. C., and Battery operated sets. Only my students could have this book in the past. Now readers of this magazine who mail the coupon will receive it free. Overcoming hum, noises of all kinds, fading signals, broad tuning, howls and oscillations, poor distance reception, distorted or muffled signals, poor Audio and Radio Frequency amplification and other vital information is contained in it. Get a free copy by mailing the coupon below.

NEW Radio Equipment for Broad Practical Experience Given Without Extra Charge

With this equipment you work out many of the things you read about in your text books. From it you get the valuable experience that tells an expert from a beginner. In a short time you have learned what would take years to learn in the field. You make experiments illustrating the important principles in the 25 best known receiving sets.



I have doubled and tripled the salaries of many. Find out about this tested way to **BIGGER PAY**



FILL OUT AND MAIL THIS COUPON TODAY

J. E. SMITH, President
National Radio Institute, Dept. 2DB3
Washington, D. C.

I want to take advantage of your special free offer. Send me your two books "Rich Rewards in Radio" and "Trouble Shooting in D.C., A.C., and Battery Sets". I understand this request does not obligate me and that no salesman will call.

Name.....
Address.....
City.....State.....

M

Lifetime Employment Service to all Graduates

SM

McMurdo Silver
presents

COLOR-TUNING

SHORT-WAVE



LONG-WAVE

Model 727SW

ONE DIAL—CALIBRATED
NEW PATENTED CIRCUIT*

TRUE AUTOMATIC VOLUME CONTROL

METER-TUNING

FRACTIONAL MICROVOLT SENSITIVITY

ABSOLUTE 10KC SELECTIVITY

PENTODE—VARIO-MU TUBES

Price, for Chassis and Speaker
\$99.50 List. Write for discounts.

*727SW is fully covered by Patents Applied For and all infringements will be vigorously prosecuted.

SILVER-MARSHALL, Inc.

6457 W. 65th St.

CHICAGO, U. S. A.

SILVER-
MARSHALL, Inc.
6457 W. 65th St.
Chicago, U. S. A.

Please send me all details
on 727SW and latest catalogue.

Name.....

Address.....

Super Power

insures

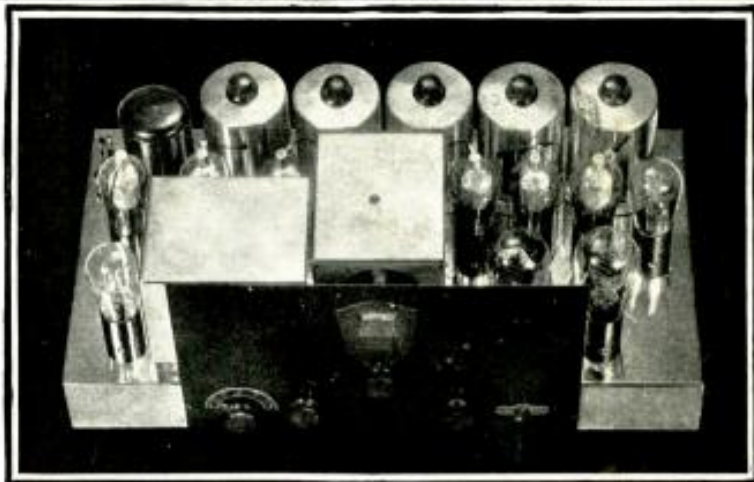

World-Wide Performance- 15 TO 550 METERS-NO PLUG-IN COILS

Lincoln Super powered receivers are bringing in the finest reports we ever received. New short-wave stations coming on the air are reported to us from the Pacific Coast to New York City.

From California comes the following report: "I have picked up many SW stations. Sidney, Rio de Janeiro, Indo-China, Rome, Russia, Australia, Manila, Saigon, Mexico, Hawaii, Fiji Islands, and Siam. This is only a small list of stations picked up on the Lincoln. We tried out five other well known makes of widely advertised AC all-wave receivers, but found the Lincoln in a class by itself."

Selectivity

Many fine reports of extreme selectivity reflect the precision engineering of Lincoln equipment. A recent report from Staten Island, New York states: "Received WLW 700 K.C. WOR 710 K.C. WGN 720 K.C. CMK Cuba 725 K.C. Canadian 730 K.C. XER 735 K.C. WSB 740 K.C." Note the 5 K.C. separation of powerful stations.

A New Conception of Short-Wave Reception

The application of Lincoln's mighty power to the reception of short-waves produces truly amazing results. Stations half-way around the world come in with clock like regularity. Lincoln enthusiasts in the central states have repeatedly reported *broadcast* reception of

many trans-Pacific stations. The tremendous amplification of the highly engineered Lincoln circuit is always perfectly controlled in a channel less than 10 K.C. wide. A letter from Alaska reports reception of Mexico, Nebraska and Vancouver, B. C., all three stations 5 K.C. apart!

Full, Rich, Life-Like Lincoln Tone

Lincoln tone is a revelation of purity and fidelity. Lincoln experts have designed an audio system that, with either radio or phonograph pick-up input, delivers tone of astonishing richness and realism. Artificial tone compensators or control devices are not required to bring out the natural vivid tone of the living artist.

DeLuxe DC-SW-10, Battery Model, Is Extremely Efficient

The Lincoln DeLuxe DC-SW-10 is the battery model version of the famous DeLuxe SW-32 described above. Taking advantage of the new low drain 2 volt tubes, the DC-SW-10, when operated from an adequate battery source, provides exceptionally quiet, crystal clear reception of both broadcast and short-waves. This model, although intended for rural or un electrified areas, is finding increasing favor in congested city communities because of its absolute freedom from line noise and clear life-like tone quality.

Clip and Mail NOW!

LINCOLN
DE LUXE-SW-32

LINCOLN RADIO CORPORATION

Dept. SWC-6, 329 S. Wood St., CHICAGO, ILL.

Please send descriptive literature to NAME.....
ADDRESS..... CITY..... STATE.....